



**YAMAHA**

**2007**

*MOTOMATRIX*

**YZF-R1(W)**

**SERVICE MANUAL**

4C8-28197-E0

EAS20040

**YZF-R1(W)  
SERVICE MANUAL  
©2006 by Yamaha Motor Co., Ltd.  
First edition, October 2006  
All rights reserved.  
Any reproduction or unauthorized use  
without the written permission of  
Yamaha Motor Co., Ltd.  
is expressly prohibited.**

EAS20070

## NOTICE

This manual was produced by the Yamaha Motor Company, Ltd. primarily for use by Yamaha dealers and their qualified mechanics. It is not possible to include all the knowledge of a mechanic in one manual. Therefore, anyone who uses this book to perform maintenance and repairs on Yamaha vehicles should have a basic understanding of mechanics and the techniques to repair these types of vehicles. Repair and maintenance work attempted by anyone without this knowledge is likely to render the vehicle unsafe and unfit for use.

This model has been designed and manufactured to perform within certain specifications in regard to performance and emissions. Proper service with the correct tools is necessary to ensure that the vehicle will operate as designed. If there is any question about a service procedure, it is imperative that you contact a Yamaha dealer for any service information changes that apply to this model. This policy is intended to provide the customer with the most satisfaction from his vehicle and to conform to federal environmental quality objectives.

Yamaha Motor Company, Ltd. is continually striving to improve all of its models. Modifications and significant changes in specifications or procedures will be forwarded to all authorized Yamaha dealers and will appear in future editions of this manual where applicable.

### NOTE:

- This Service Manual contains information regarding periodic maintenance to the emission control system. Please read this material carefully.
  - Designs and specifications are subject to change without notice.
- 

EAS20080

## IMPORTANT MANUAL INFORMATION

Particularly important information is distinguished in this manual by the following.



The Safety Alert Symbol means ATTENTION! BECOME ALERT! YOUR SAFETY IS INVOLVED!



Failure to follow WARNING instructions could result in severe injury or death to the vehicle operator, a bystander or a person checking or repairing the vehicle.



A CAUTION indicates special precautions that must be taken to avoid damage to the vehicle.

### NOTE:

A NOTE provides key information to make procedures easier or clearer.

EAS20090

# HOW TO USE THIS MANUAL

This manual is intended as a handy, easy-to-read reference book for the mechanic. Comprehensive explanations of all installation, removal, disassembly, assembly, repair and check procedures are laid out with the individual steps in sequential order.

- The manual is divided into chapters and each chapter is divided into sections. The current section title is shown at the top of each page "1".
- Sub-section titles appear in smaller print than the section title "2".
- To help identify parts and clarify procedure steps, there are exploded diagrams at the start of each removal and disassembly section "3".
- Numbers are given in the order of the jobs in the exploded diagram. A number indicates a disassembly step "4".
- Symbols indicate parts to be lubricated or replaced "5".
- Refer to "SYMBOLS".
- A job instruction chart accompanies the exploded diagram, providing the order of jobs, names of parts, notes in jobs, etc "6".
- Jobs requiring more information (such as special tools and technical data) are described sequentially "7".

1  
↓  
**CLUTCH**

**EAS20090**  
**CLUTCH**

Removing the clutch cover

3  
4  
5  
6

Order	Job/Parts to remove	Q'ty	Remarks
	Right side cowling		Refer to "GENERAL CHASSIS" on page 4-1.
	Bottom cowlings		Refer to "GENERAL CHASSIS" on page 4-1.
	Engine oil		Refer to "CHANGING THE ENGINE OIL" on page 3-12.
1	Cover	1	
2	Clutch cable	1	Disconnect.
3	Clutch cover	1	
4	Clutch cover gasket	1	
5	Dowel pin	2	
6	Oil filler cap	1	

For installation, reverse the removal procedure.

5-43

**CLUTCH**

**Clutch plate "2"**

Part No.	Thickness	STD
5VY-16325-00	2.0 mm (0.079 in)	
4B1-16325-00	2.3 mm (0.091 in)	

**NOTE:**  
When adjusting the clutch assembly width (by replacing the clutch plate(s)), be sure to replace the clutch plate "1" fast.  
After replacing the clutch plate "1", if specifications cannot be met, replace the clutch plate "2".

**EAS20140**  
**CHECKING THE CLUTCH SPRINGS**  
The following procedure applies to all of the clutch springs:

1. Check:
  - Clutch spring
  - Damage → Replace the clutch springs as a set.
2. Measure:
  - Clutch spring free length "a"
  - Out of specification → Replace the clutch springs as a set.

**Clutch spring free length**  
43.80 mm (1.72 in)  
**Limit**  
41.61 mm (1.64 in)

**EAS20100**  
**CHECKING THE CLUTCH HOUSING**

1. Check:
  - Clutch housing dogs
  - Damage/pitting/wear → Deburr the clutch housing dogs or replace the clutch housing.

**NOTE:**  
Fitting on the clutch housing dogs will cause erratic clutch operation.
2. Check:
  - Bearing
  - Damage/wear → Replace the bearing and clutch housing.

**EAS20100**  
**CHECKING THE CLUTCH BOSS**

1. Check:
  - Clutch boss splines
  - Damage/pitting/wear → Replace the clutch boss.

**NOTE:**  
Fitting on the clutch boss splines will cause erratic clutch operation.
2. Check:
  - Clutch boss
  - Cracks/damage → Replace.

5-48

EAS20100

## SYMBOLS

The following symbols are used in this manual for easier understanding.

**NOTE:** \_\_\_\_\_

The following symbols are not relevant to every vehicle.

16. Replace the part

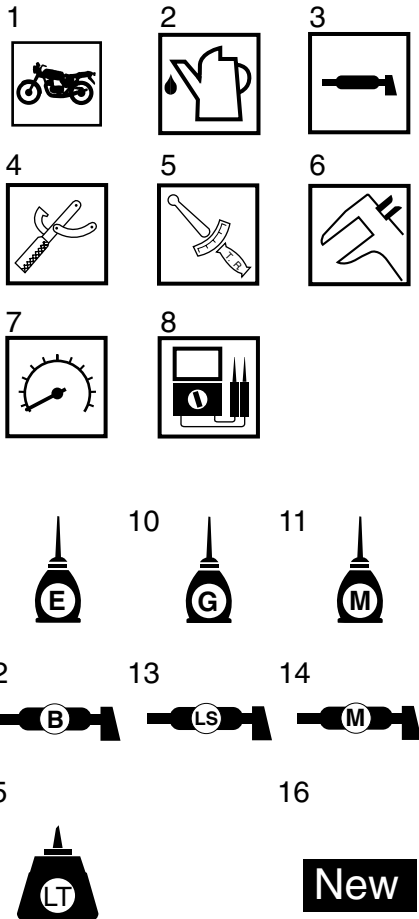

1. Serviceable with engine mounted
2. Filling fluid
3. Lubricant
4. Special tool
5. Tightening torque
6. Wear limit, clearance
7. Engine speed
8. Electrical data
9. Engine oil
10. Gear oil
11. Molybdenum-disulfide oil
12. Wheel-bearing grease
13. Lithium-soap-based grease
14. Molybdenum-disulfide grease
15. Apply locking agent (LOCTITE®)



EAS20110

# TABLE OF CONTENTS

<b>GENERAL INFORMATION</b>	<b>1</b>
<b>SPECIFICATIONS</b>	<b>2</b>
<b>PERIODIC CHECKS AND ADJUSTMENTS</b>	<b>3</b>
<b>CHASSIS</b>	<b>4</b>
<b>ENGINE</b>	<b>5</b>
<b>COOLING SYSTEM</b>	<b>6</b>
<b>FUEL SYSTEM</b>	<b>7</b>
<b>ELECTRICAL SYSTEM</b>	<b>8</b>
<b>TROUBLESHOOTING</b>	<b>9</b>



---

## GENERAL INFORMATION

<b>IDENTIFICATION</b> .....	1-1
VEHICLE IDENTIFICATION NUMBER.....	1-1
MODEL LABEL .....	1-1
<b>FEATURES</b> .....	1-2
FI SYSTEM.....	1-3
YCC-T (Yamaha Chip Controlled Throttle)	
YCC-I (Yamaha Chip Controlled Intake) .....	1-4
<b>IMPORTANT INFORMATION</b> .....	1-12
PREPARATION FOR REMOVAL AND DISASSEMBLY .....	1-12
REPLACEMENT PARTS.....	1-12
GASKETS, OIL SEALS AND O-RINGS.....	1-12
LOCK WASHERS/PLATES AND COTTER PINS .....	1-12
BEARINGS AND OIL SEALS .....	1-13
CIRCLIPS .....	1-13
<b>CHECKING THE CONNECTIONS</b> .....	1-14
<b>SPECIAL TOOLS</b> .....	1-15



## IDENTIFICATION

---

EAS20130

### IDENTIFICATION

EAS20140

#### VEHICLE IDENTIFICATION NUMBER

The vehicle identification number "1" is stamped into the right side of the steering head pipe.

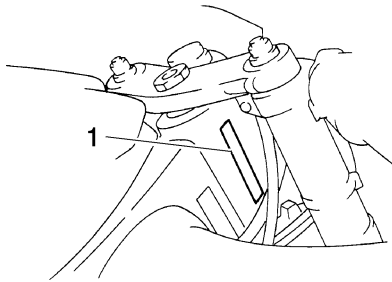

EAS20150

#### MODEL LABEL

The model label "1" is affixed to the frame. This information will be needed to order spare parts.

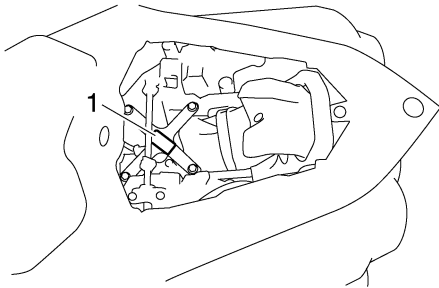

# FEATURES

EAS20170

## FEATURES

### OUTLINE OF THE FI SYSTEM

The main function of a fuel supply system is to provide fuel to the combustion chamber at the optimum air-fuel ratio in accordance with the engine operating conditions and the atmospheric temperature. In the conventional carburetor system, the air-fuel ratio of the mixture that is supplied to the combustion chamber is created by the volume of the intake air and the fuel that is metered by the jet used in the respective carburetor.

Despite the same volume of intake air, the fuel volume requirement varies by the engine operating conditions, such as acceleration, deceleration, or operating under a heavy load. Carburetors that meter the fuel through the use of jets have been provided with various auxiliary devices, so that an optimum air-fuel ratio can be achieved to accommodate the constant changes in the operating conditions of the engine.

As the requirements for the engine to deliver more performance and cleaner exhaust gases increase, it becomes necessary to control the air-fuel ratio in a more precise and finely tuned manner. To accommodate this need, this model has adopted an electronically controlled fuel injection (FI) system, in place of the conventional carburetor system. This system can achieve an optimum air-fuel ratio required by the engine at all times by using a microprocessor that regulates the fuel injection volume according to the engine operating conditions detected by various sensors. The adoption of the FI system has resulted in a highly precise fuel supply, improved engine response, better fuel economy, and reduced exhaust emissions.

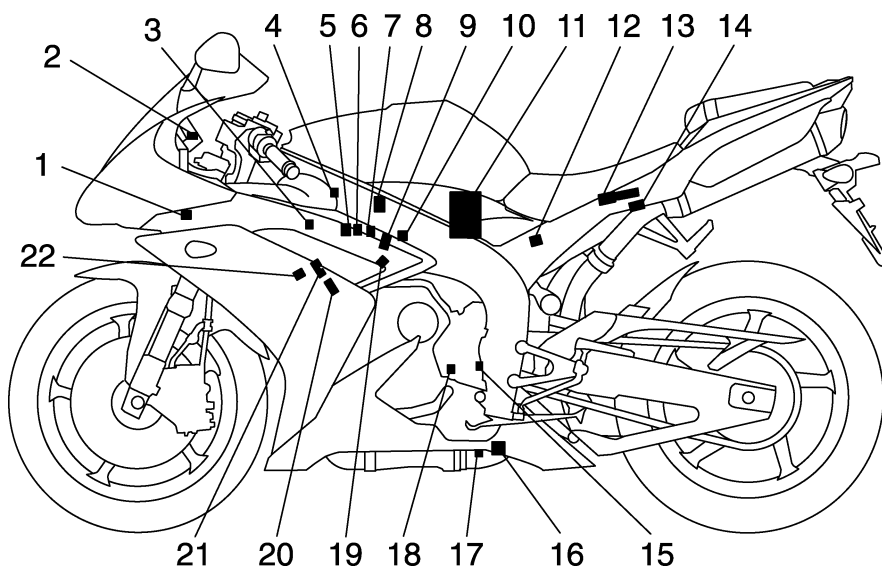

- |   |                                    |
|---|------------------------------------|
| 1. Intake air temperature sensor                        | 14. Starting circuit cut-off relay |
| 2. Engine trouble warning light                         | 15. Speed sensor                   |
| 3. Air induction system solenoid                        | 16. EXUP servo motor               |
| 4. Atmospheric pressure sensor                          | 17. O <sub>2</sub> sensor          |
| 5. Throttle position sensor (for throttle cable pulley) | 18. Crankshaft position sensor     |
| 6. Throttle servo motor                                 | 19. Coolant temperature sensor     |
| 7. Throttle position sensor (for throttle valves)       | 20. Spark plug                     |
| 8. Intake funnel servo motor                            | 21. Ignition coil                  |
| 9. Injector   | 22. Cylinder identification sensor |
| 10. Intake air pressure sensor                          |                                    |
| 11. Fuel pump   |                                    |
| 12. Lean angle sensor                                   |                                    |
| 13. ECU (engine control unit)                           |                                    |

## FEATURES

EAS4C81010

### FI SYSTEM

The fuel pump delivers fuel to the fuel injector via the fuel filter. The pressure regulator maintains the fuel pressure that is applied to the fuel injector at only 324 kPa (3.24 kg/cm<sup>2</sup>, 46.1 psi). Accordingly, when the energizing signal from the ECU energizes the fuel injector, the fuel passage opens, causing the fuel to be injected into the intake manifold only during the time the passage remain open.

Therefore, the longer the length of time the fuel injector is energized (injection duration), the greater the volume of fuel that is supplied. Conversely, the shorter the length of time the fuel injector is energized (injection duration), the lesser the volume of fuel that is supplied.

The injection duration and the injection timing are controlled by the ECU. Signals that are input from the throttle position sensor (for throttle valves), throttle position sensor (for throttle cable pulley), crankshaft position sensor, intake air pressure sensor, intake air temperature sensor, coolant temperature sensor, atmospheric pressure sensor, cylinder identification sensor, lean angle sensor, speed sensor and O<sub>2</sub> sensor enable the ECU to determine the injection duration. The injection timing is determined through the signals from the crankshaft position sensor. As a result, the volume of fuel that is required by the engine can be supplied at all times in accordance with the driving conditions.

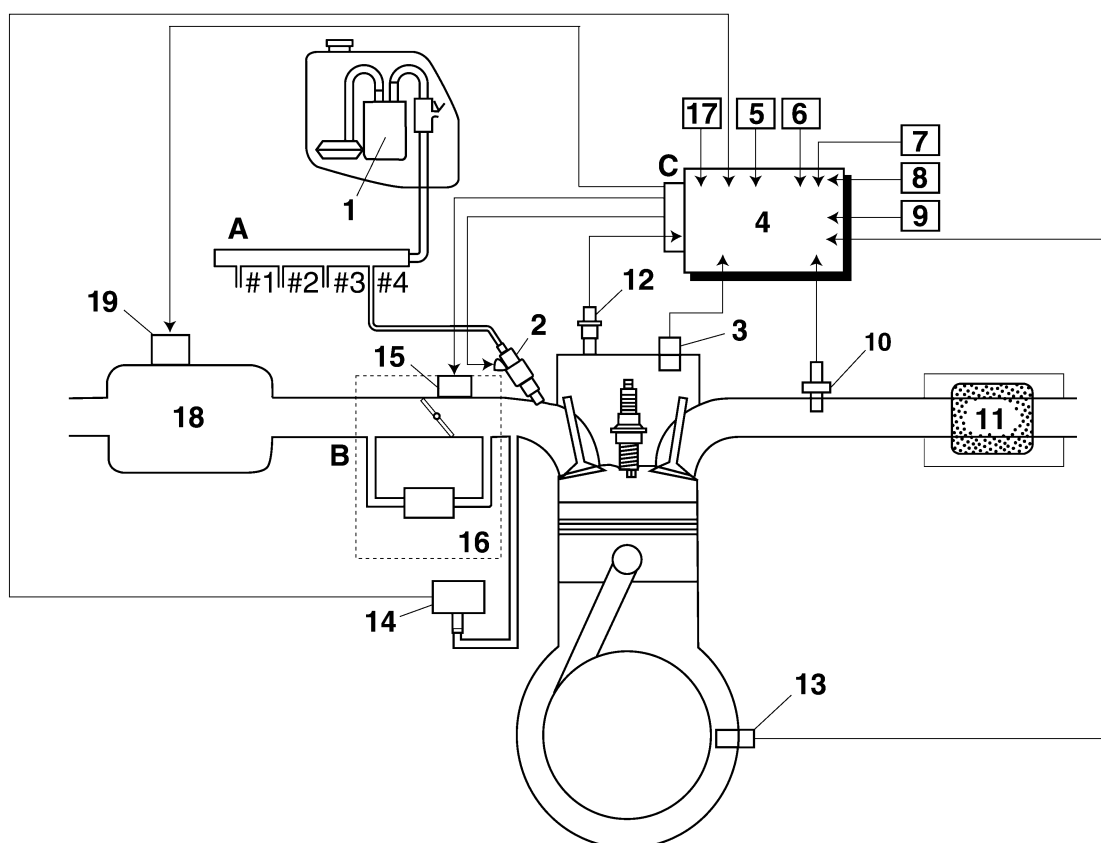

- |   |                                 |
|---|---------------------------------|
| 1. Fuel pump  | 12. Coolant temperature sensor  |
| 2. Injector   | 13. Crankshaft position sensor  |
| 3. Cylinder identification sensor                       | 14. Intake air pressure sensor  |
| 4. ECU (engine control unit)                            | 15. Throttle servo motor        |
| 5. Throttle position sensor (for throttle valves)       | 16. Throttle body               |
| 6. Throttle position sensor (for throttle cable pulley) | 17. Atmospheric pressure sensor |
| 7. Speed sensor   | 18. Air filter case             |
| 8. Intake air temperature sensor                        | 19. Intake funnel servo motor   |
| 9. Lean angle sensor                                    | A. Fuel system                  |
| 10. O <sub>2</sub> sensor                               | B. Air system                   |
| 11. Catalytic converter                                 | C. Control system               |

EAS4C81011

**YCC-T (Yamaha Chip Controlled Throttle)****YCC-I (Yamaha Chip Controlled Intake)****Mechanism characteristics**

Yamaha developed the YCC-T and YCC-I system employing the most advanced electronic control technologies.

Electronic control throttle systems have been used on automobiles, but Yamaha has developed a faster, more compact system specifically for the needs of a sports motorcycle. The Yamaha-developed system has a high-speed calculating capacity that produces computations of running conditions every 1/1000th of a second.

The YCC-T system is designed to respond to the throttle action of the rider by having the ECU instantaneously calculate the ideal throttle valve opening and generate signals to operate the motor-driven throttle valves and thus actively control the intake air volume.

The ECU contains three CPUs with a capacity about five times that of conventional units, making it possible for the system to respond extremely quickly to the slightest adjustments made by the rider. In particular, optimized control of the throttle valve opening provides the optimum volume of intake air for easy-to-use torque, even in a high-revving engine

The YCC-I system calculates the value from the engine revolution number and throttle opening rate, activates the intake air funnel with the electronic control motor drive to control the intake pipe length in order to gain the high power output in all revolution ranges from low speeds to high speeds.

**Aims and advantages of using YCC-T system**

- Increased engine power  
By shortening the air intake path, higher engine speed is possible → Increased engine power.
- Improved driveability  
Air intake volume is controlled according to the operating conditions → Improved throttle response to meet engine requirement.  
Driving force is controlled at the optimal level according to the transmission gear position and engine speed → Improved throttle control.
- Engine braking control  
Due to the throttle control, optimal engine braking is made possible.
- Simplified idle speed control (ISC) mechanism  
The bypass mechanism and ISC actuator are eliminated → A simple mechanism is used to maintain a steady idle speed.
- Reduced weight  
Compared to using a sub-throttle mechanism, weight is reduced.

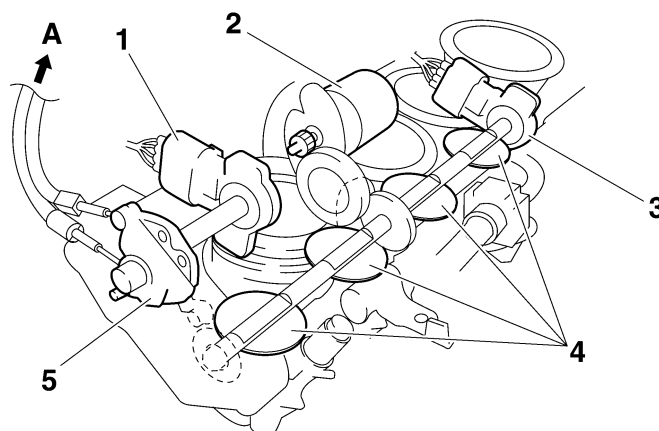

- |   |   |
|---|---|
| 1. Throttle position sensor (for throttle cable pulley) | 4. Throttle valves                          |
| 2. Throttle servo motor                                 | 5. Throttle cable pulley with linkage guard |
| 3. Throttle position sensor (for throttle valves)       | A. To throttle grip                         |

## FEATURES

### Aims and advantages of using YCC-I system

- Improvement of the engine power characteristics

The high power design in all ranges is now provided by having both two features of the short intake function to ensure the power at the high speed revolution of engine, and the long intake function to ensure the power in the practical use range.

- Intake pipe length switching control using the motor

The intake pipe length switching operation in a minute time is now available by means of the motor drive using the electronic control. The smooth power characteristic is provided, which does not let an operator feel the switching action by the optimization of its switching revolution number and the most suitable application of engine at the time of changing the revolution.

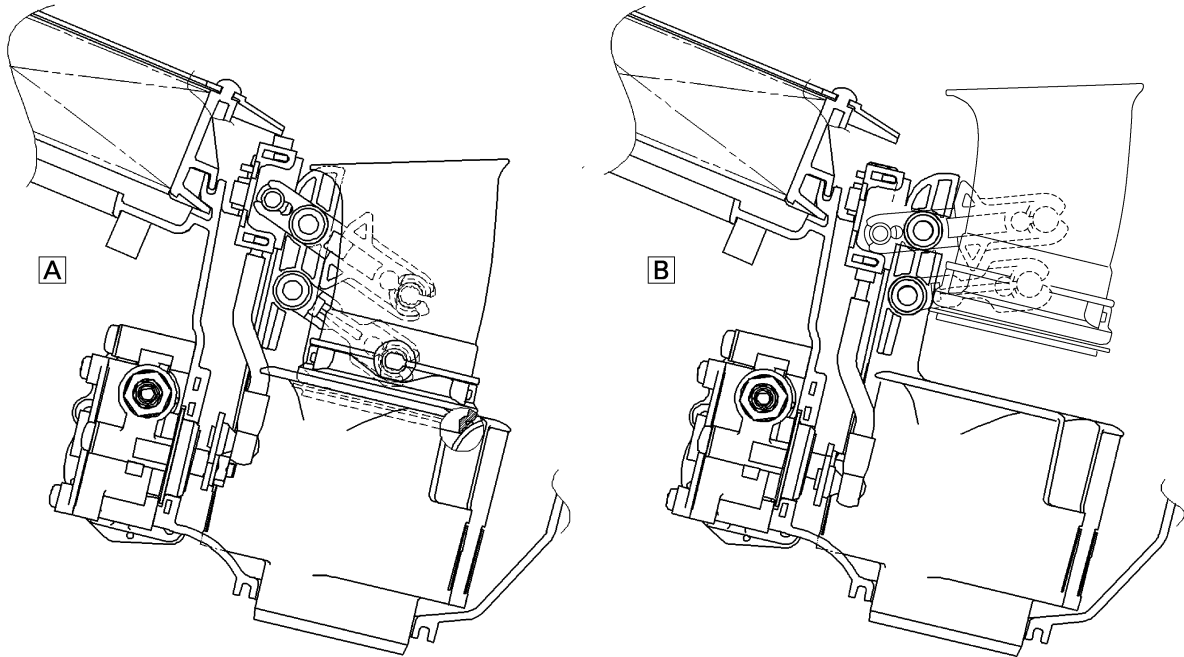

- A. Down position (long intake)  
(Low rpm to Mid rpm)
- B. Up position (short intake)  
(High rpm)

# FEATURES

## YCC-T/YCC-I system outline

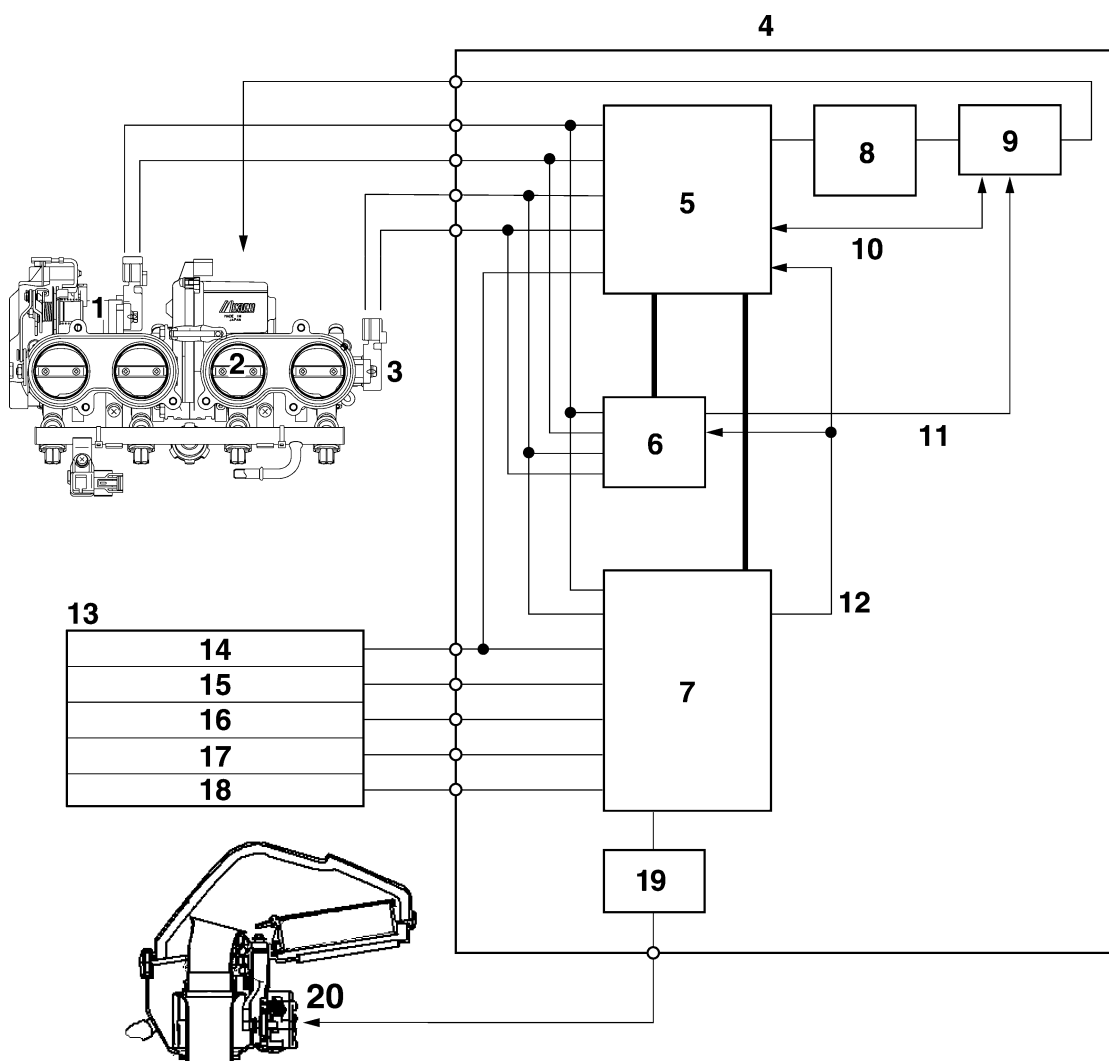

- 1. Throttle position sensor (for throttle cable pulley)
- 2. Throttle servo motor
- 3. Throttle position sensor (for throttle valves)
- 4. ECU (engine control unit)
- 5. ETV main CPU (32 bit)
- 6. ETV sub CPU (16 bit)
- 7. FI CPU (32 bit)
- 8. Throttle servo motor driver
- 9. Throttle servo motor driver operation sensing/shut off circuit
- 10. Throttle servo motor driver operation sensing feedback/emergency stop
- 11. Emergency stop
- 12. Engine revolution (pulse signal)
- 13. Sensor input
- 14. Neutral switch
- 15. Crankshaft position sensor
- 16. Speed sensor
- 17. Coolant temperature sensor
- 18. Atmospheric pressure sensor
- 19. Intake funnel servo motor driver
- 20. Intake funnel servo motor

# FEATURES

## YCC-T/YCC-I control outline

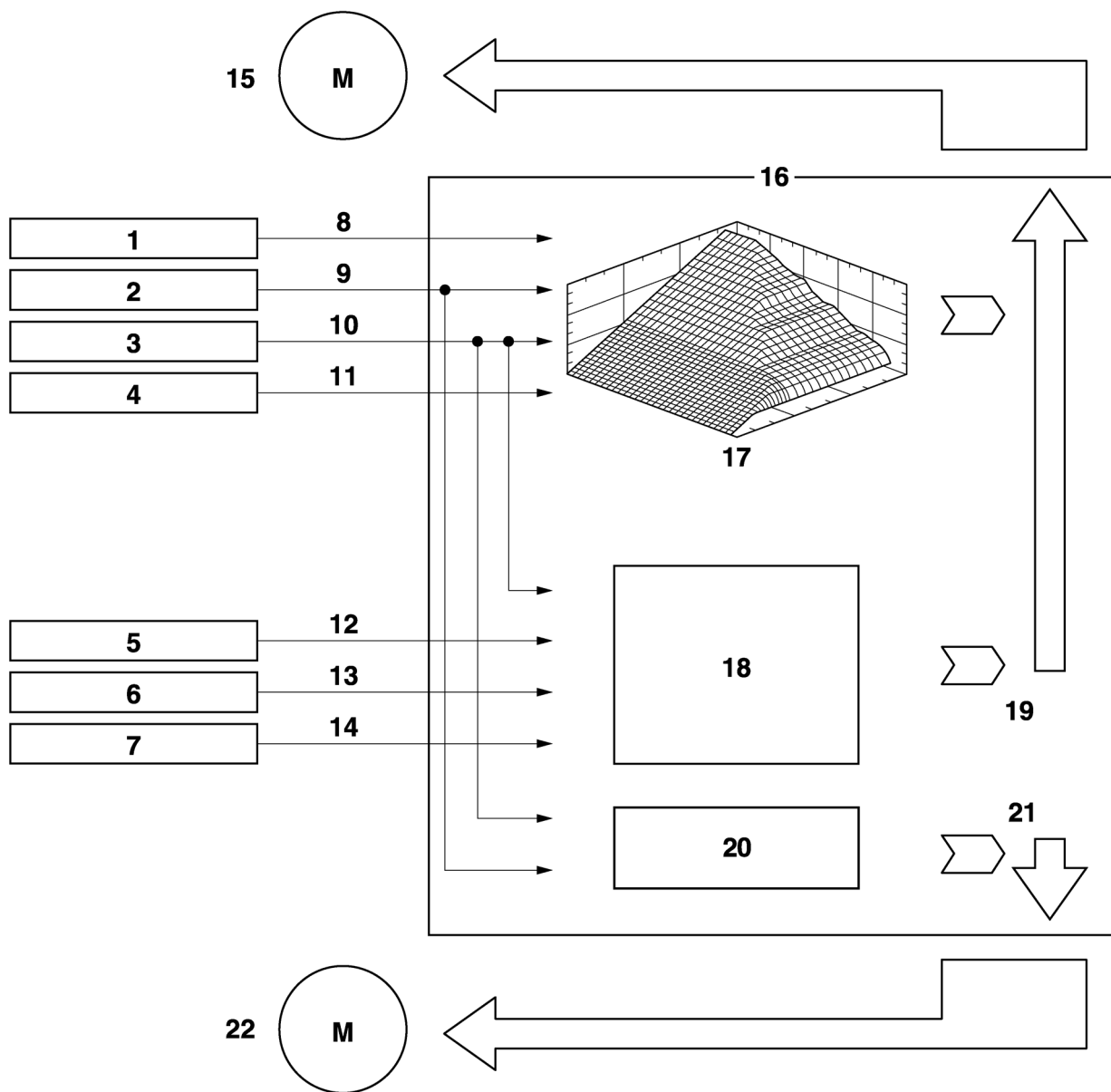

- |   |   |
|---|---|
| 1. Throttle position sensor (for throttle cable pulley) | 15. Throttle servo motor                    |
| 2. Throttle position sensor (for throttle valves)       | 16. ECU (engine control unit)               |
| 3. Crankshaft position sensor                           | 17. Base map                                |
| 4. Speed sensor   | 18. Idle speed control                      |
| 5. Coolant temperature sensor                           | 19. Calculated throttle valve opening angle |
| 6. Neutral switch                                       | 20. Base map                                |
| 7. Atmospheric pressure sensor                          | 21. Air funnel position (Calculation value) |
| 8. Accelerator position (two signals)                   | 22. Intake funnel servo motor               |
| 9. Throttle position (two signals)                      |   |
| 10. Engine revolution                                   |   |
| 11. Vehicle speed                                       |   |
| 12. Coolant temperature                                 |   |
| 13. Neutral/In gear                                     |   |
| 14. Atmospheric pressure                                |   |

## FEATURES

EAS4C81024

### INSTRUMENT FUNCTIONS

#### Multi-function meter unit

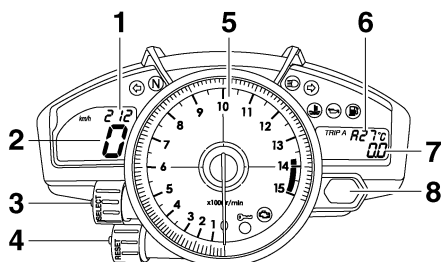

1. Clock
2. Speedometer
3. "SELECT" button
4. "RESET" button
5. Tachometer
6. Coolant temperature display/air intake temperature display
7. Odometer/tripmeters/fuel reserve tripmeter/ stopwatch
8. Shift timing indicator light

EWA4C81008

#### **WARNING**

**Be sure to stop the vehicle before making any setting changes to the multi-function meter unit.**

The multi-function meter unit is equipped with the following:

- a speedometer (which shows the riding speed)
- a tachometer (which shows engine speed)
- an odometer (which shows the total distance traveled)
- two tripmeters (which show the distance traveled since they were last set to zero)
- a fuel reserve tripmeter (which shows the distance traveled since the fuel level warning light came on)
- a clock
- a coolant temperature display
- an air intake temperature display
- a self-diagnosis device
- a display brightness and shift timing indicator light control mode

#### **NOTE:**

- Be sure to turn the key to "ON" before using the "SELECT" and "RESET" buttons.
- For the U.K. only: To switch the speedometer and odometer/tripmeter displays between

kilometers and miles, press the "SELECT" button for at least one second.

#### Tachometer

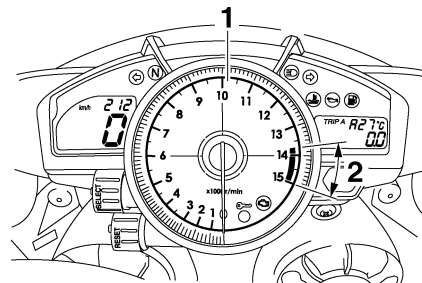

1. Tachometer
2. Tachometer red zone

The electric tachometer allows the rider to monitor the engine speed and keep it within the ideal power range.

When the key is turned to "ON", the tachometer needle will sweep once across the r/min range and then return to zero r/min in order to test the electrical circuit.

ECA4C81017

#### **CAUTION:**

**Do not operate the engine in the tachometer red zone.**

**Red zone: 13750 r/min and above**

#### Clock mode

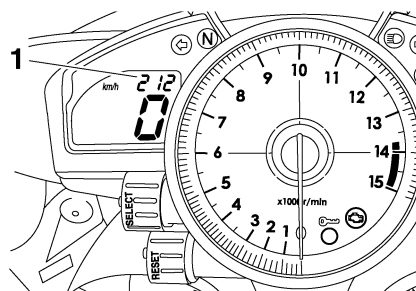

1. Clock

Turn the key to "ON".

To set the clock

1. Push the "SELECT" button and "RESET" button together for at least two seconds.
2. When the hour digits start flashing, push the "RESET" button to set the hours.
3. Push the "SELECT" button, and the minute digits will start flashing.
4. Push the "RESET" button to set the minutes.

## FEATURES

5. Push the “SELECT” button and then release it to start the clock.

### Odometer, tripmeter, and stopwatch modes

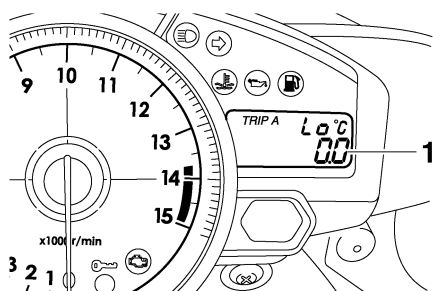

1. Odometer/tripmeter/fuel reserve tripmeter

Push the “SELECT” button to switch the display between the odometer mode “ODO” and the tripmeter modes “TRIP A” and “TRIP B” and the stopwatch mode in the following order: TRIP A → TRIP B → ODO → Stopwatch → TRIP A

If the fuel level warning light comes on, the odometer display will automatically change to the fuel reserve tripmeter mode “F-TRIP” and start counting the distance traveled from that point. In that case, push the “SELECT” button to switch the display between the various tripmeter, odometer, and stopwatch modes in the following order:

F-TRIP → Stopwatch → TRIP A → TRIP B → ODO → F-TRIP

To reset a tripmeter, select it by pushing the “SELECT” button, and then push the “RESET” button for at least one second. If you do not reset the fuel reserve tripmeter manually, it will reset itself automatically and the display will return to the prior mode after refueling and traveling 5 km (3 mi).



### Stopwatch mode

To change the display to the stopwatch mode, select it by pushing the “SELECT” button. (The stopwatch digits will start flashing.) Release the “SELECT” button, and then push it again for a few seconds until the stopwatch digits stop flashing.

#### Standard measurement

1. Push the “RESET” button to start the stopwatch.
2. Push the “SELECT” button to stop the stopwatch.
3. Push the “SELECT” button again to reset the stopwatch.

#### Split-time measurement

1. Push the “RESET” button to start the stopwatch.
2. Push the “RESET” button or start switch “” to measure split-times. (The colon “:” will start flashing.)
3. Push the “RESET” button or start switch “” to measure split-times. (The colon “:” will start flashing.)
4. Push the “SELECT” button to reset the stopwatch.

#### NOTE:

To change the display back to the prior mode, push the “SELECT” button for a few seconds.

### Coolant temperature display

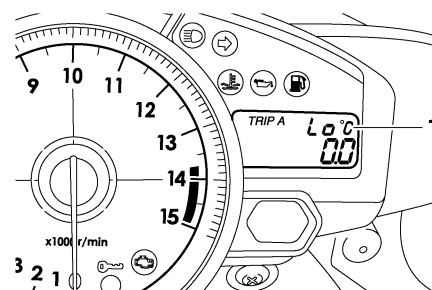

1. Coolant temperature display

The coolant temperature display indicates the temperature of the coolant.

Push the “RESET” button to switch the coolant temperature display to the air intake temperature display.

#### NOTE:

When the coolant temperature display is selected, “C” is displayed for one second, and then the coolant temperature is displayed.

ECA4C81018

#### CAUTION:

**Do not operate the engine if it is overheated.**

## FEATURES

### Air intake temperature display

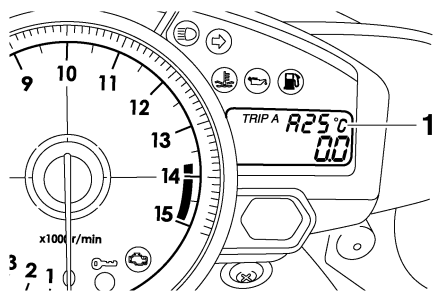

1. Air intake temperature display

The air intake temperature display indicates the temperature of the air drawn into the air filter case. Push the “RESET” button to switch the coolant temperature display to the air intake temperature display.

**NOTE:**

- Even if the air intake temperature is set to be displayed, the coolant temperature warning light comes on when the engine overheats.
- When the key is turned to “ON”, the coolant temperature is automatically displayed, even if the air intake temperature was displayed prior to turning the key to “OFF”.
- When the air intake temperature display is selected, “A” is displayed before the temperature.

### Self-diagnosis device

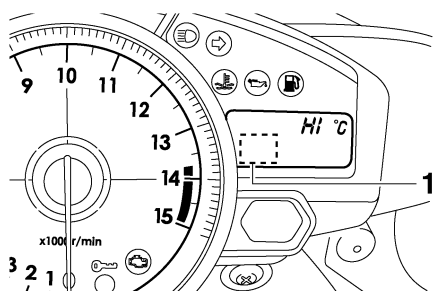

1. Error code display

This model is equipped with a self-diagnosis device for various electrical circuits. If any of those circuits are defective, the engine trouble warning light will come on, and then the display will indicate a two-digit error code. This model is also equipped with a self-diagnosis device for the immobilizer system. If any of the immobilizer system circuits are defective, the immobilizer system indicator

light will flash, and then the display will indicate a two-digit error code.

**NOTE:**

If the display indicates error code 52, this could be caused by transponder interference. If this error code appears, try the following.

1. Use the code re-registering key to start the engine.

**NOTE:**

Make sure there are no other immobilizer keys close to the main switch, and do not keep more than one immobilizer key on the same key ring! Immobilizer system keys may cause signal interference, which may prevent the engine from starting

2. If the engine starts, turn it off and try starting the engine with the standard keys.
3. If one or both of the standard keys do not start the engine, take the vehicle, the code re-registering key and both standard keys to a Yamaha dealer and have the standard keys re-registered.

If the display indicates any error codes, note the code number, and then have a Yamaha dealer check the vehicle.

ECA4C81019

**CAUTION:**

**If the display indicates an error code, the vehicle should be checked as soon as possible in order to avoid engine damage.**

### Display brightness and shift timing indicator light control mode

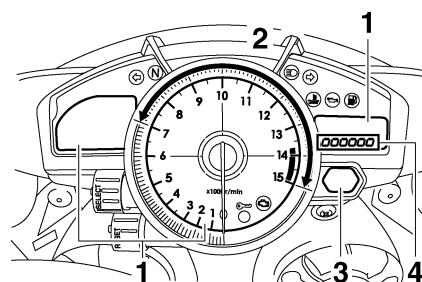

1. Display brightness
2. Shift timing indicator light activation/deactivation
3. Shift timing indicator light
4. Brightness level

## FEATURES

This mode cycles through five control functions, allowing you to make the following settings in the order listed below.

Display brightness:

- This function allows you to adjust the brightness of the displays and tachometer to suit the outside lighting conditions.
- Shift timing indicator light activity:  
This function allows you to choose whether or not the indicator light should be activated and whether it should flash or stay on when activated.
- Shift timing indicator light activation:  
This function allows you to select the engine speed at which the indicator light will be activated.
- Shift timing indicator light deactivation:  
This function allows you to select the engine speed at which the indicator light will be deactivated.
- Shift timing indicator light brightness:  
This function allows you to adjust the brightness of the indicator light to suit your preference.

**NOTE:**

In this mode, the right display shows the current setting for each function (except the shift timing indicator light activity function).

To adjust the brightness of the multifunction meter displays and tachometer

1. Turn the key to "OFF".
2. Push and hold the "SELECT" button.
3. Turn the key to "ON", and then release the "SELECT" button after five seconds.
4. Push the "RESET" button to select the desired brightness level.
5. Push the "SELECT" button to confirm the selected brightness level. The control mode changes to the shift timing indicator light activity function.

To set the shift timing indicator light activity function

1. Push the "RESET" button to select one of the following indicator light activity settings:
  - The indicator light will stay on when activated. (This setting is selected when the indicator light stays on.)
  - The indicator light will flash when activated. (This setting is selected when the indicator light flashes four times per second.)
  - The indicator light is deactivated; in other words, it will not come on or flash. (This

setting is selected when the indicator light flashes once every two seconds.)

2. Push the "SELECT" button to confirm the selected indicator light activity. The control mode changes to the shift timing indicator light activation function.

To set the shift timing indicator light activation function

**NOTE:**

The shift timing indicator light activation function can be set between 7000 r/min and 15000 r/min. From 7000 r/min to 12000 r/min, the indicator light can be set in increments of 500 r/min. From 12000 r/min to 15000 r/min, the indicator light can be set in increments of 200 r/min.

1. Push the "RESET" button to select the desired engine speed for activating the indicator light.
2. Push the "SELECT" button to confirm the selected engine speed. The control mode changes to the shift timing indicator light deactivation function.

To set the shift timing indicator light deactivation function

**NOTE:**

- The shift timing indicator light deactivation function can be set between 7000 r/min and 15000 r/min. From 7000 r/min to 12000 r/min, the indicator light can be set in increments of 500 r/min. From 12000 r/min to 15000 r/min, the indicator light can be set in increments of 200 r/min.
- Be sure to set the deactivation function to a higher engine speed than for the activation function, otherwise the shift timing indicator light will remain deactivated.

1. Push the "RESET" button to select the desired engine speed for deactivating the indicator light.
2. Push the "SELECT" button to confirm the selected engine speed. The control mode changes to the shift timing indicator light brightness function.

To adjust the shift timing indicator light brightness

1. Push the "RESET" button to select the desired indicator light brightness level.
2. Push the "SELECT" button to confirm the selected indicator light brightness level. The right display will return to the odometer or tripmeter mode.

# IMPORTANT INFORMATION

EAS20180

## IMPORTANT INFORMATION

EAS20190

### PREPARATION FOR REMOVAL AND DISASSEMBLY

1. Before removal and disassembly, remove all dirt, mud, dust and foreign material.



2. Use only the proper tools and cleaning equipment. Refer to "SPECIAL TOOLS" on page 1-15.
3. When disassembling, always keep mated parts together. This includes gears, cylinders, pistons and other parts that have been "mated" through normal wear. Mated parts must always be reused or replaced as an assembly.

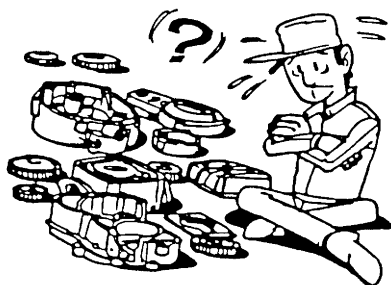

4. During disassembly, clean all of the parts and place them in trays in the order of disassembly. This will speed up assembly and allow for the correct installation of all parts.
5. Keep all parts away from any source of fire.

EAS20200

### REPLACEMENT PARTS

Use only genuine Yamaha parts for all replacements. Use oil and grease recommended by Yamaha for all lubrication jobs. Other brands may be similar in function and appearance, but inferior in quality.

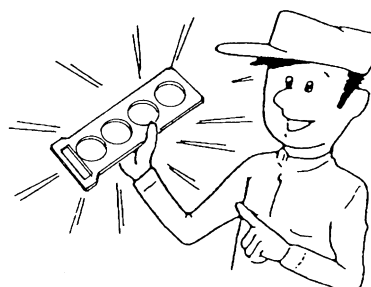

EAS20210

### GASKETS, OIL SEALS AND O-RINGS

1. When overhauling the engine, replace all gaskets, seals and O-rings. All gasket surfaces, oil seal lips and O-rings must be cleaned.
2. During reassembly, properly oil all mating parts and bearings and lubricate the oil seal lips with grease.

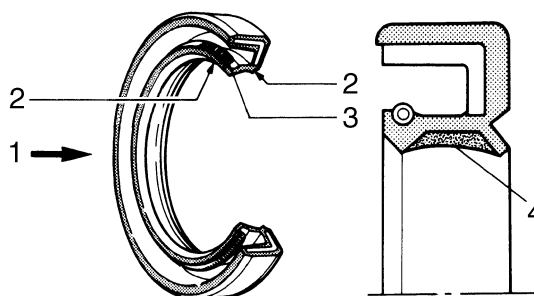

1. Oil
2. Lip
3. Spring
4. Grease

EAS20220

### LOCK WASHERS/PLATES AND COTTER PINS

After removal, replace all lock washers/plates "1" and cotter pins. After the bolt or nut has been tightened to specification, bend the lock tabs along a flat of the bolt or nut.

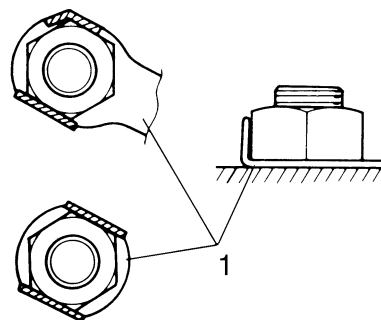

## IMPORTANT INFORMATION

EAS20230

### BEARINGS AND OIL SEALS

Install bearings "1" and oil seals "2" so that the manufacturer's marks or numbers are visible. When installing oil seals, lubricate the oil seal lips with a light coat of lithium-soap-based grease. Oil bearings liberally when installing, if appropriate.

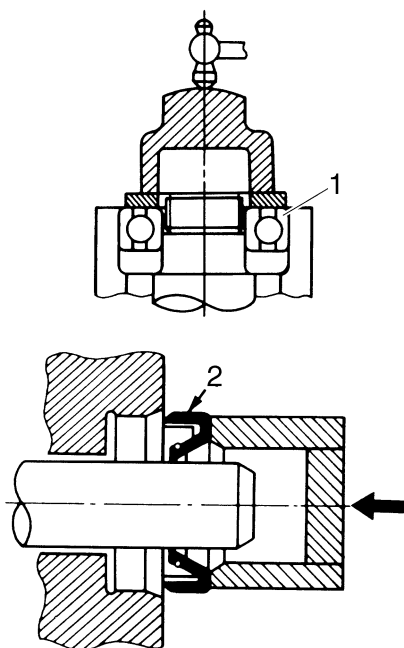

ECA13300

### CAUTION:

**Do not spin the bearing with compressed air because this will damage the bearing surfaces.**

EAS20240

### CIRCLIPS

Before reassembly, check all circlips carefully and replace damaged or distorted circlips. Always replace piston pin clips after one use. When installing a circlip "1", make sure the sharp-edged corner "2" is positioned opposite the thrust "3" that the circlip receives.

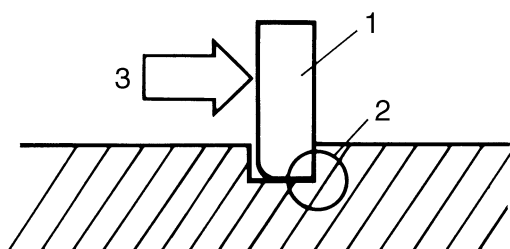

## CHECKING THE CONNECTIONS

EAS20250

### CHECKING THE CONNECTIONS

Check the leads, couplers, and connectors for stains, rust, moisture, etc.

1. Disconnect:

- Lead
- Coupler
- Connector

2. Check:

- Lead
- Coupler
- Connector

Moisture → Dry with an air blower.

Rust/stains → Connect and disconnect several times.

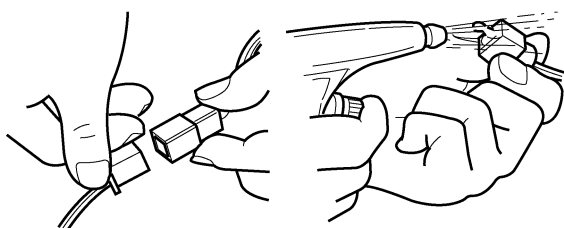

3. Check:

- All connections
- Loose connection → Connect properly.

**NOTE:**

If the pin "1" on the terminal is flattened, bend it up.

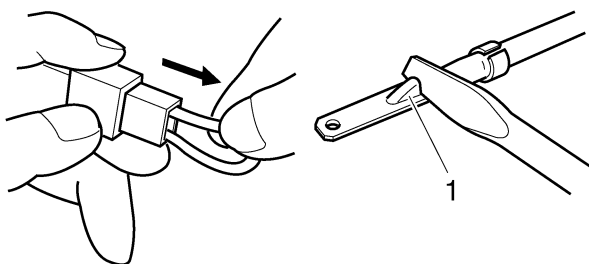

4. Connect:

- Lead
- Coupler
- Connector

**NOTE:**

Make sure all connections are tight.

5. Check:

- Continuity  
(with the pocket tester)



**Pocket tester**  
**90890-03112**  
**Analog pocket tester**  
**YU-03112-C**

**NOTE:**

- If there is no continuity, clean the terminals.
- When checking the wire harness, perform steps (1) to (3).
- As a quick remedy, use a contact revitalizer available at most part stores.

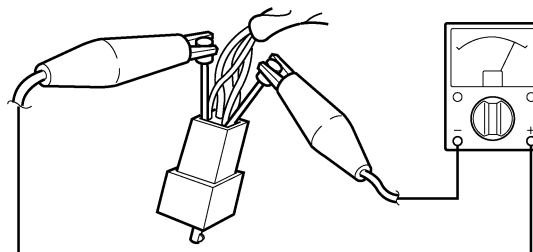
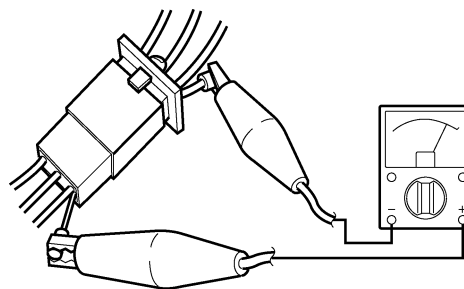

## SPECIAL TOOLS

EAS20260

### SPECIAL TOOLS

The following special tools are necessary for complete and accurate tune-up and assembly. Use only the appropriate special tools as this will help prevent damage caused by the use of inappropriate tools or improvised techniques. Special tools, part numbers or both may differ depending on the country.

When placing an order, refer to the list provided below to avoid any mistakes.

**NOTE:**

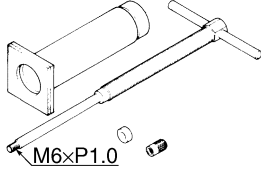
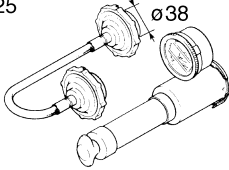
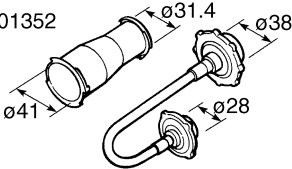
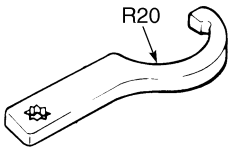
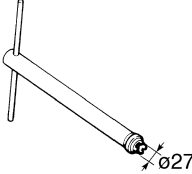
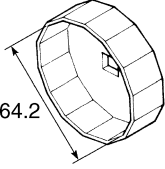

- For U.S.A. and Canada, use part number starting with “YM-”, “YU-”, or “ACC-”.
- For others, use part number starting with “90890-”.

Tool name/Tool No.	Illustration	Reference pages
Piston pin puller set 90890-01304 Piston pin puller YU-01304	90890-01304 	5-71
Radiator cap tester 90890-01325 Radiator pressure tester YU-24460-01	90890-01325 	6-3
Radiator cap tester adapter 90890-01352 Radiator pressure tester adapter YU-33984	90890-01352 	6-3
Steering nut wrench 90890-01403 Spanner wrench YU-33975		3-29, 4-60
Damper rod holder 90890-01423 Damping rod holder YM-01423		4-53, 4-54
Oil filter wrench 90890-01426 YU-38411		3-13

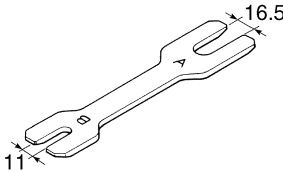
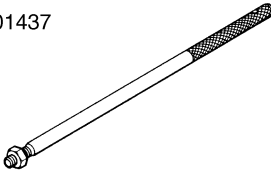
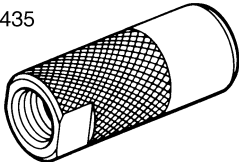
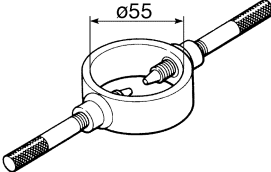
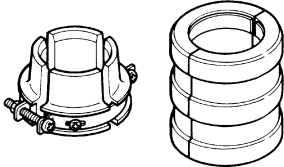
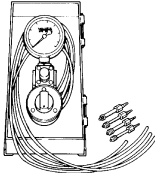
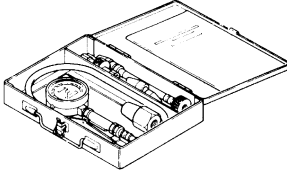
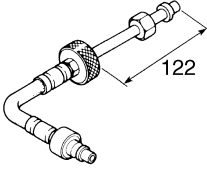

**SPECIAL TOOLS**

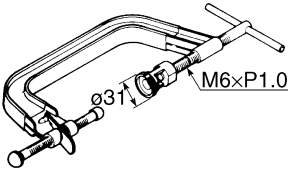
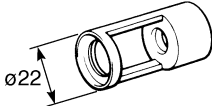
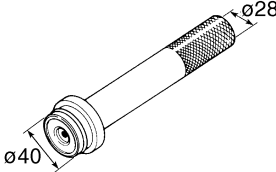
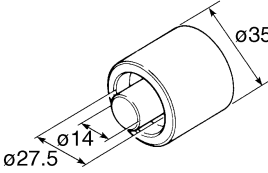
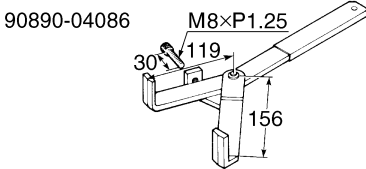
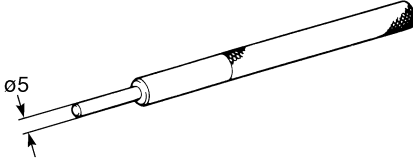
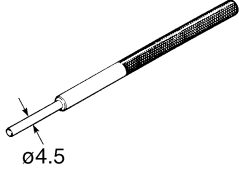
Tool name/Tool No.	Illustration	Reference pages
Rod holder 90890-01434 Damper rod holder double ended YM-01434		4-52, 4-57
Rod puller 90890-01437 Universal damping rod bleeding tool set YM-A8703	<p>90890-01437</p> 	4-56, 4-57
Rod puller attachment (M12) 90890-01435 Universal damping rod bleeding tool set YM-A8703	<p>90890-01435</p> 	4-56, 4-57
Fork spring compressor 90890-01441 YM-01441		4-52, 4-57
Fork seal driver 90890-01442 Adjustable fork seal driver (36–46 mm) YM-01442		4-55
Vacuum gauge 90890-03094 Carburetor synchronizer YU-44456	<p>90890-03094</p> 	3-7
Compression gauge 90890-03081 Engine compression tester YU-33223		3-11
Extension 90890-04136		3-11

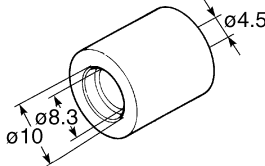
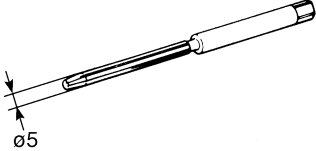
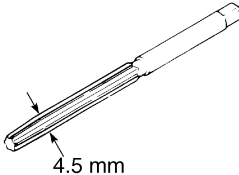
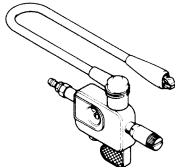
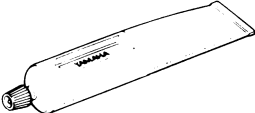
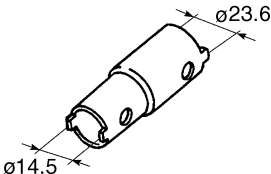

## SPECIAL TOOLS

Tool name/Tool No.	Illustration	Reference pages
Valve spring compressor 90890-04019 YM-04019		5-23, 5-29
Valve spring compressor attachment 90890-04108 Valve spring compressor adapter (22 mm) YM-04108		5-23, 5-29
Middle driven shaft bearing driver 90890-04058 Bearing driver (40 mm) YM-04058		6-11
Mechanical seal installer 90890-04078 Water pump seal installer YM-33221-A		6-11
Universal clutch holder 90890-04086 YM-91042		5-47, 5-51
Valve guide remover (ø5) 90890-04097 Valve guide remover (5.0 mm) YM-04097		5-25
Valve guide remover (ø4.5) 90890-04116 Valve guide remover (4.5 mm) YM-04116		5-25
Valve guide installer (ø5) 90890-04098 Valve guide installer (5.0 mm) YM-04098		5-25

**SPECIAL TOOLS**

Tool name/Tool No.	Illustration	Reference pages
Valve guide installer (ø4.5) 90890-04117 Valve guide installer (4.5 mm) YM-04117		5-25
Valve guide reamer (ø5) 90890-04099 Valve guide reamer (5.0 mm) YM-04099		5-25
Valve guide reamer (ø4.5) 90890-04118 Valve guide reamer (4.5mm) YM-04118		5-25
Ignition checker 90890-06754 Opama pet-4000 spark checker YU-34487		8-95
Yamaha bond No.1215 (Three Bond No.1215) 90890-85505		5-67, 6-11
Pivot shaft wrench 90890-01471 Frame spanner socket YM-01471		5-7
Pivot shaft wrench adapter 90890-01476		5-7

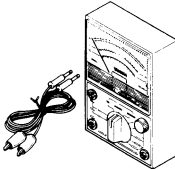
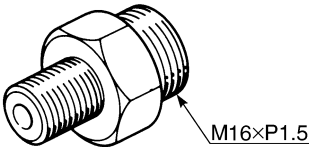
## SPECIAL TOOLS

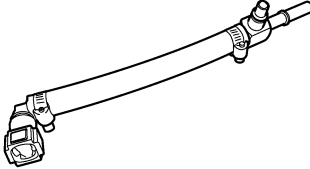
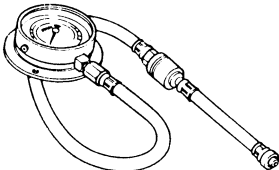
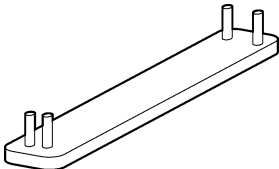
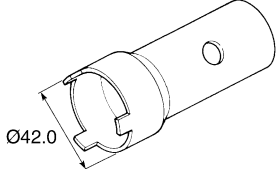
Tool name/Tool No.	Illustration	Reference pages
Pocket tester 90890-03112 Analog pocket tester YU-03112-C		1-14, 5-41, 8-87, 8-88, 8-89, 8-92, 8-93, 8-94, 8-95, 8-96, 8-97, 8-98, 8-99, 8-100, 8-101, 8-102, 8-103
Oil pressure gauge adapter 90890-03139		3-14
Valve lapper 90890-04101 Valve lapping tool YM-A8998		3-5
Fuel pressure adapter 90890-03176 YM-03176		7-6
Pressure gauge 90890-03153 YU-03153		3-14, 7-6
Camshaft wrench 90890-04143 YM-04143		5-11, 5-16
Ring nut wrench 90890-01507 YM-01507		4-68, 4-70

## SPECIAL TOOLS

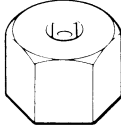
Tool name/Tool No.	Illustration	Reference pages
Damper rod holder (22 mm) 90890-01365		4-69, 4-70

## **SPECIAL TOOLS**

---

---

## SPECIFICATIONS

<b>GENERAL SPECIFICATIONS</b> .....	2-1
<b>ENGINE SPECIFICATIONS</b> .....	2-2
<b>CHASSIS SPECIFICATIONS</b> .....	2-9
<b>ELECTRICAL SPECIFICATIONS</b> .....	2-11
<b>TIGHTENING TORQUES</b> .....	2-13
GENERAL TIGHTENING TORQUE SPECIFICATIONS .....	2-13
ENGINE TIGHTENING TORQUES .....	2-14
CHASSIS TIGHTENING TORQUES .....	2-18
<b>LUBRICATION POINTS AND LUBRICANT TYPES</b> .....	2-21
ENGINE .....	2-21
CHASSIS .....	2-22
<b>LUBRICATION SYSTEM CHART AND DIAGRAMS</b> .....	2-23
ENGINE OIL LUBRICATION CHART .....	2-23
LUBRICATION DIAGRAMS .....	2-25
<b>COOLING SYSTEM DIAGRAMS</b> .....	2-35
<b>CABLE ROUTING</b> .....	2-39

## GENERAL SPECIFICATIONS

---

EAS20280

### GENERAL SPECIFICATIONS

---

#### Model

Model	4C81 (EUR) 4C82 (FRA, BEL) 4C83 (AUS)
-------	---

---

#### Dimensions

Overall length	2060 mm (81.1 in)
Overall width	720 mm (28.3 in)
Overall height	1110 mm (43.7 in)
Seat height	835 mm (32.9 in)
Wheelbase	1415 mm (55.7 in)
Ground clearance	135 mm (5.31 in)
Minimum turning radius	3400 mm (133.9 in)

---

#### Weight

With oil and fuel	200 kg (441 lb)
Maximum load	195 kg (430 lb)

**ENGINE SPECIFICATIONS**

EAS20290

**ENGINE SPECIFICATIONS****Engine**

Engine type	Liquid cooled 4-stroke, DOHC
Displacement	998.0 cm <sup>3</sup>
Cylinder arrangement	Forward-inclined parallel 4-cylinder
Bore × stroke	77.0 × 53.6 mm (3.03 × 2.11 in)
Compression ratio	12.70 :1
Standard compression pressure (at sea level)	1480 kPa/350 r/min (210.5 psi/350 r/min) (14.8 kgf/cm <sup>2</sup> /350 r/min)
Starting system	Electric starter

**Fuel**

Recommended fuel	Premium unleaded gasoline only
Fuel tank capacity	18.0 L (4.76 US gal) (3.96 Imp.gal)
Fuel reserve amount	3.2 L (0.85 US gal) (0.70 Imp.gal)

**Engine oil**

Lubrication system	Wet sump
Type	SAE10W30, SAE10W40, SAE15W40, SAE20W40 or SAE20W50
Recommended engine oil grade	API service, SG type or higher, JASO standard MA

**Engine oil quantity**

Total amount	3.83 L (4.05 US qt) (3.37 Imp.qt)
Without oil filter cartridge replacement	2.90 L (3.07 US qt) (2.55 Imp.qt)
With oil filter cartridge replacement	3.10 L (3.28 US qt) (2.73 Imp.qt)

**Oil filter**

Oil filter type	Formed
-----------------	--------

**Oil pump**

Oil pump type	Trochoid
Inner-rotor-to-outer-rotor-tip clearance	0.010–0.100 mm (0.0004–0.0039 in)
Limit	0.18 mm (0.0071 in)
Outer-rotor-to-oil-pump-housing clearance	0.090–0.190 mm (0.0035–0.0074 in)
Limit	0.26 mm (0.0102 in)
Oil-pump-housing-to-inner-and-outer-rotor clearance	0.06–0.13 mm (0.0024–0.0051 in)
Limit	0.20 mm (0.0079 in)
Bypass valve opening pressure	80.0–120.0 kPa (11.6–17.4 psi) (0.80–1.20 kgf/cm <sup>2</sup> )
Relief valve operating pressure	600.0–680.0 kPa (87.0–98.6 psi) (6.00–6.80 kgf/cm <sup>2</sup> )

**Cooling system**

Radiator capacity (including all routes)	2.76 L (2.92 US qt) (2.43 Imp.qt)
Coolant reservoir capacity (up to the maximum level mark)	0.25 L (0.26 US qt) (0.22 Imp.qt)
Radiator cap opening pressure	108–137 kPa (15.4–19.5 psi) (1.08–1.37 kgf/cm <sup>2</sup> )

**Radiator core**

Width	374.0 mm (14.72 in)
Height	257.8 mm (10.15 in)
Depth	24.0 mm (0.94 in)

**Water pump**

Water pump type	Single suction centrifugal pump
Reduction ratio	65/43 × 25/32 (1.181)

## ENGINE SPECIFICATIONS

### Spark plug (s)

Manufacturer/model  
Spark plug gap

NGK/CR9EK  
0.6–0.7 mm (0.024–0.028 in)

### Cylinder head

Volume  
Warpage limit\*

14.00–14.80 cm<sup>3</sup> (0.85–0.90 cu.in)  
0.10 mm (0.0039 in)

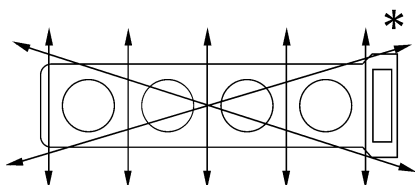

### Camshaft

Drive system  
Camshaft cap inside diameter  
Camshaft journal diameter  
Camshaft-journal-to-camshaft-cap clearance

Chain drive (right)  
24.500–24.521 mm (0.9646–0.9654 in)  
24.459–24.472 mm (0.9630–0.9635 in)  
0.028–0.062 mm (0.0011–0.0024 in)

### Camshaft lobe dimensions

Intake A	34.450–34.550 mm (1.3563–1.3602 in)
Limit	34.350 mm (1.3524 in)
Intake B	25.170–25.270 mm (0.9909–0.9949 in)
Limit	25.070 mm (0.9870 in)
Exhaust A	33.550–33.650 mm (1.3209–1.3248 in)
Limit	33.450 mm (1.3169 in)
Exhaust B	25.192–25.292 mm (0.9918–0.9957 in)
Limit	25.092 mm (0.9879 in)

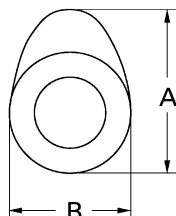

Camshaft runout limit

0.030 mm (0.0012 in)

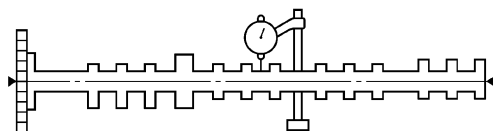

### Timing chain

Model/number of links  
Tensioning system

RH2020/124  
Automatic

### Valve clearance (cold)

Intake  
Exhaust

0.11–0.20 mm (0.0043–0.0079 in)  
0.26–0.30 mm (0.0102–0.0118 in)

### Valve dimensions

Valve head diameter A (intake)

30.90–31.10 mm (1.2165–1.2244 in)

## ENGINE SPECIFICATIONS

Valve head diameter A (exhaust) 24.90–25.10 mm (0.9803–0.9882 in)

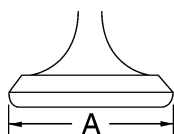

Valve face width B (intake) 1.200–2.480 mm (0.0472–0.0976 in)  
 Valve face width B (exhaust) 1.625–2.900 mm (0.0640–0.1142 in)

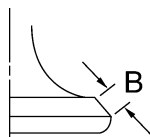

Valve seat width C (intake) 0.90–1.10 mm (0.0354–0.0433 in)  
 Valve seat width C (exhaust) 0.90–1.10 mm (0.0354–0.0433 in)

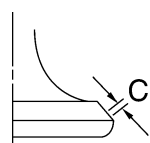

Valve margin thickness D (intake) 1.10–1.50 mm (0.0433–0.0591 in)  
 Valve margin thickness D (exhaust) 0.50–0.90 mm (0.0197–0.0354 in)

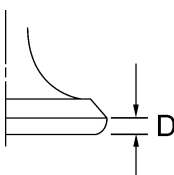

Valve stem diameter (intake) 4.975–4.990 mm (0.1959–0.1965 in)  
 Limit 4.960 mm (0.1953 in)  
 Valve stem diameter (exhaust) 4.460–4.475 mm (0.1756–0.1762 in)  
 Limit 4.425 mm (0.1742 in)  
 Valve guide inside diameter (intake) 5.000–5.012 mm (0.1969–0.1973 in)  
 Limit 5.050 mm (0.1988 in)  
 Valve guide inside diameter (exhaust) 4.500–4.512 mm (0.1772–0.1776 in)  
 Limit 4.550 mm (0.1791 in)  
 Valve-stem-to-valve-guide clearance (intake) 0.010–0.037 mm (0.0004–0.0015 in)  
 Limit 0.080 mm (0.0032 in)  
 Valve-stem-to-valve-guide clearance (exhaust) 0.025–0.052 mm (0.0010–0.0020 in)  
 Limit 0.100 mm (0.0039 in)  
 Valve stem runout 0.010 mm (0.0004 in)

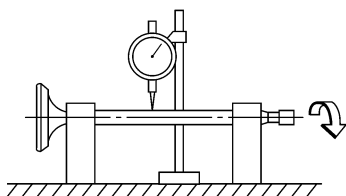

Cylinder head valve seat width (intake) 0.90–1.10 mm (0.0354–0.0433 in)  
 Cylinder head valve seat width (exhaust) 0.90–1.10 mm (0.0354–0.0433 in)

### Valve spring

Inner spring  
 Free length (intake) 39.79 mm (1.57 in)  
 Free length (exhaust) 38.42 mm (1.51 in)

## ENGINE SPECIFICATIONS

Installed length (intake)	35.50 mm (1.40 in)
Installed length (exhaust)	33.00 mm (1.30 in)
Spring rate K1 (intake)	42.91 N/mm (245.02 lb/in) (4.38 kgf/mm)
Spring rate K2 (intake)	56.23 N/mm (321.07 lb/in) (5.73 kgf/mm)
Spring rate K1 (exhaust)	40.10 N/mm (228.97 lb/in) (4.09 kgf/mm)
Spring rate K2 (exhaust)	51.85 N/mm (296.06 lb/in) (5.29 kgf/mm)
Installed compression spring force (intake)	171–197 N (38.44–44.29 lbf) (17.44–20.09 kgf) at 35.50 mm (1.398 in)
Installed compression spring force (exhaust)	202–232 N (45.41–52.15 lbf) (20.60–23.66 kgf) at 33.00 mm (1.299 in)
Spring tilt (intake)*	2.5 °/1.7 mm
Spring tilt (exhaust)*	2.5 °/1.7 mm

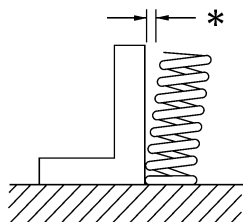

Winding direction (intake)	Clockwise
Winding direction (exhaust)	Clockwise

### Cylinder

Bore	77.000–77.010 mm (3.0315–3.0319 in)
Taper limit	0.050 mm (0.0020 in)
Out of round limit	0.050 mm (0.0020 in)

### Piston

Piston-to-cylinder clearance	0.010–0.035 mm (0.0004–0.0014 in)
Limit	0.12 mm (0.0047 in)
Diameter D	76.975–76.990 mm (3.0305–3.0311 in)
Height H	12.0 mm (0.47 in)

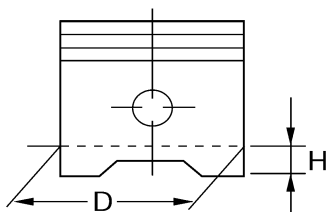

Offset	0.50 mm (0.0197 in)
Offset direction	Intake side
Piston pin bore inside diameter	17.002–17.013 mm (0.6694–0.6698 in)
Piston pin outside diameter	16.991–17.000 mm (0.6689–0.6693 in)

## ENGINE SPECIFICATIONS

### Piston ring

Top ring

Ring type

Barrel

Dimensions (B × T)

0.90 × 2.75 mm (0.04 × 0.11 in)

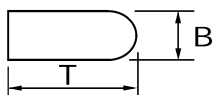

End gap (installed)

0.15–0.25 mm (0.0059–0.0098 in)

Ring side clearance

0.030–0.065 mm (0.0012–0.0026 in)

2nd ring

Ring type

Taper

Dimensions (B × T)

0.80 × 2.75 mm (0.03 × 0.11 in)

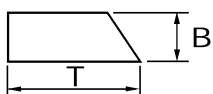

End gap (installed)

0.30–0.45 mm (0.0118–0.0177 in)

Ring side clearance

0.020–0.055 mm (0.0008–0.0022 in)

Oil ring

Dimensions (B × T)

1.50 × 2.25 mm (0.06 × 0.09 in)

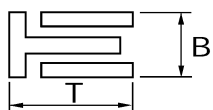

End gap (installed)

0.10–0.40 mm (0.0039–0.0157 in)

### Connecting rod

Oil clearance (using plastigauge®)

0.034–0.058 mm (0.0013–0.0023 in)

Bearing color code

1.Blue 2.Black 3.Brown 4.Green

### Crankshaft

Width A

55.20–56.60 mm (2.173–2.228 in)

Width B

298.75–300.65 mm (11.76–11.84 in)

Runout limit C

0.030 mm (0.0012 in)

Big end side clearance D

0.160–0.262 mm (0.0063–0.0103 in)

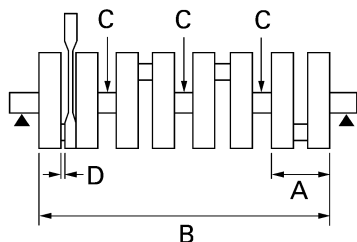

Journal oil clearance (using plastigauge®)

0.014–0.037 mm (0.0006–0.0015 in)

Bearing color code

0.White 1.Blue 2.Black 3.Brown 4.Green

## ENGINE SPECIFICATIONS

---

### Clutch

Clutch type	Wet, multiple-disc
Clutch release method	Outer pull, rack and pinion pull
Clutch lever free play	10.0–15.0 mm (0.39–0.59 in)
Friction plate thickness	2.90–3.10 mm (0.114–0.122 in)
Wear limit	2.80 mm (0.1102 in)
Plate quantity	9 pcs
Clutch plate thickness	1.90–2.10 mm (0.075–0.083 in)
Plate quantity	8 pcs
Warpage limit	0.10 mm (0.0039 in)
Clutch spring free length	43.80 mm (1.72 in)
Spring quantity	6 pcs

---

### Transmission

Transmission type	Constant mesh 6-speed
Primary reduction system	Spur gear
Primary reduction ratio	65/43 (1.512)
Secondary reduction system	Chain drive
Secondary reduction ratio	45/17 (2.647)
Operation	Left foot operation

**ENGINE SPECIFICATIONS****Gear ratio**

1st	38/15 (2.533)
2nd	33/16 (2.063)
3rd	37/21 (1.762)
4th	35/23 (1.522)
5th	30/22 (1.364)
6th	33/26 (1.269)
Main axle runout limit	0.08 mm (0.0032 in)
Drive axle runout limit	0.08 mm (0.0032 in)

**Shifting mechanism**

Shift mechanism type	Shift drum and guide bar
Shift fork guide bar bending limit	0.100 mm (0.0039 in)
Shift fork thickness	5.80–5.88 mm (0.2283–0.2315 in)

**Air filter**

Air filter element	Oil-coated paper element
--------------------	--------------------------

**Fuel pump**

Pump type	Electrical
Model/manufacture	4C8/DENSO
Maximum consumption amperage	6.0 A
Output pressure	324.0 kPa (46.1 psi) (3.24 kgf/cm <sup>2</sup> )

**Fuel injector**

Model/quantity	297500-1110/4
Manufacturer	DENSO

**Throttle body**

Type/quantity	45E1DW/1
Manufacturer	MIKUNI
ID mark	4C81 00
Throttle valve size	#50

**Throttle position sensor**

Resistance	2.0–3.0 k $\Omega$
Output voltage (at idle)	0.63–0.73 V

**Idling condition**

Engine idling speed	1150–1250 r/min
Intake vacuum	22.0 kPa (6.5 inHg) (165 mmHg)
Water temperature	95.0–105.0 °C (203.00–221.00 °F)
Oil temperature	80.0–90.0 °C (176.00–194.00 °F)
Throttle cable free play	3.0–5.0 mm (0.12–0.20 in)

**CHASSIS SPECIFICATIONS**

EAS20300

**CHASSIS SPECIFICATIONS****Chassis**

Frame type	Diamond
Caster angle	24.00 °
Trail	102.0 mm (4.02 in)

**Front wheel**

Wheel type	Cast wheel
Rim size	17M/C x MT3.50
Rim material	Aluminum
Wheel travel	120.0 mm (4.72 in)
Radial wheel runout limit	1.0 mm (0.04 in)
Lateral wheel runout limit	0.5 mm (0.02 in)

**Rear wheel**

Wheel type	Cast wheel
Rim size	17M/C x MT6.00
Rim material	Aluminum
Wheel travel	130.0 mm (5.12 in)
Radial wheel runout limit	1.0 mm (0.04 in)
Lateral wheel runout limit	0.5 mm (0.02 in)

**Front tire**

Type	Tubeless
Size	120/70 ZR17M/C (58W)
Manufacturer/model	MICHELIN/Pilot POWER P
Manufacturer/model	PIRELLI/DIABLO CORSA E
Wear limit (front)	0.8 mm (0.03 in)

**Rear tire**

Type	Tubeless
Size	190/50 ZR17M/C (73W)
Manufacturer/model	MICHELIN/ Pilot POWER
Manufacturer/model	PIRELLI/DIABLO CORSA L
Wear limit (rear)	0.8 mm (0.03 in)

**Tire air pressure (measured on cold tires)**

Loading condition	0–90 kg (0–198 lb)
Front	250 kPa (36 psi) (2.50 kgf/cm <sup>2</sup> ) (2.50 bar)
Rear	290 kPa (42 psi) (2.90 kgf/cm <sup>2</sup> ) (2.90 bar)
Loading condition	90–195 kg (198–430 lb)
Front	250 kPa (36 psi) (2.50 kgf/cm <sup>2</sup> ) (2.50 bar)
Rear	290 kPa (42 psi) (2.90 kgf/cm <sup>2</sup> ) (2.90 bar)
High-speed riding	
Front	250 kPa (36 psi) (2.50 kgf/cm <sup>2</sup> ) (2.50 bar)
Rear	290 kPa (42 psi) (2.90 kgf/cm <sup>2</sup> ) (2.90 bar)

**Front brake**

Type	Dual disc brake
Operation	Right hand operation
Front brake lever free play	2.3–11.5 mm (0.09–0.45 in)

**Front disc brake**

Disc outside diameter × thickness	310.0 × 5.0 mm (12.20 × 0.20 in)
Brake disc thickness limit	4.5 mm (0.18 in)
Brake disc deflection limit	0.10 mm (0.0039 in)
Brake pad lining thickness (inner)	4.5 mm (0.18 in)
Limit	0.8 mm (0.03 in)
Brake pad lining thickness (outer)	4.5 mm (0.18 in)
Limit	0.8 mm (0.03 in)

**CHASSIS SPECIFICATIONS**

Master cylinder inside diameter	16.00 mm (0.63 in)
Caliper cylinder inside diameter	24.05 mm × 3 (0.95 in × 3)
Recommended fluid	DOT 4
<b>Rear brake</b>	
Type	Single disc brake
Operation	Right foot operation
Brake pedal free play	4.3–9.3 mm (0.17–0.37 in)
<b>Rear disc brake</b>	
Disc outside diameter × thickness	220.0 × 5.0 mm (8.66 × 0.20 in)
Brake disc thickness limit	4.5 mm (0.18 in)
Brake disc deflection limit	0.15 mm (0.0059 in)
Brake pad lining thickness (inner)	6.0 mm (0.24 in)
Limit	1.0 mm (0.04 in)
Brake pad lining thickness (outer)	6.0 mm (0.24 in)
Limit	1.0 mm (0.04 in)
Master cylinder inside diameter	12.7 mm (0.50 in)
Caliper cylinder inside diameter	38.18 mm (1.50 in)
Recommended fluid	DOT 4
<b>Steering</b>	
Steering bearing type	Angular bearing
Lock to lock angle (left)	27.0 °
Lock to lock angle (right)	27.0 °
<b>Front suspension</b>	
Type	Telescopic fork
Spring/shock absorber type	Coil spring/oil damper
Front fork travel	120.0 mm (4.72 in)
Fork spring free length	237.5 mm (9.35 in)
Limit	232.8 mm (9.17 in)
Collar length	100.0 mm (3.94 in)
Installed length	223.0 mm (8.78 in)
Spring rate K1	9.07 N/mm (51.79 lb/in) (0.92 kgf/mm)
Spring stroke K1	0.0–120.0 mm (0.00–4.72 in)
Inner tube outer diameter	43.0 mm (1.69 in)
Inner tube bending limit	0.2 mm (0.01 in)
Optional spring available	No
Recommended oil	Suspension oil 01 or equivalent
Quantity	513.0 cm <sup>3</sup> (17.34 US oz) (18.09 Imp.oz)
Level	101.0 mm (3.98 in)
<b>Rear suspension</b>	
Type	Swingarm (link suspension)
Spring/shock absorber type	Coil spring/gas-oil damper
Rear shock absorber assembly travel	65.0 mm (2.56 in)
Spring free length	179.5 mm (7.07 in)
Installed length	166.5 mm (6.56 in)
Spring rate K1	93.00 N/mm (531.03 lb/in) (9.48 kgf/mm)
Spring stroke K1	0.0–65.0 mm (0.00–2.56 in)
Optional spring available	No
Enclosed gas/air pressure (STD)	1200 kPa (170.7 psi) (12.0 kgf/cm <sup>2</sup> )
<b>Drive chain</b>	
Type/manufacturer	50VA8/DAIDO
Link quantity	118
Drive chain slack	30.0–40.0 mm (1.18–1.57 in)
15-link length limit	239.3 mm (9.42 in)

**ELECTRICAL SPECIFICATIONS**

EAS20310

**ELECTRICAL SPECIFICATIONS****Voltage**

System voltage 12 V

**Ignition system**Ignition system Transistorized coil ignition (digital)  
Ignition timing (B.T.D.C.) 5.0 °/1050 r/min**Engine control unit**Model/manufacture TBDF37/DENSO (4C81, 4C83)  
TBDF41/DENSO (4C82)**Ignition coil**Model/manufacture F6T568/MITSUBISHI  
Minimum ignition spark gap 6.0 mm (0.24 in)  
Primary coil resistance 0.85–1.15  $\Omega$  at 20 °C (68 °F)  
Secondary coil resistance 5.02–6.79 k $\Omega$  at 20 °C (68 °F)**AC magneto**Model/manufacture F4T850/MITSUBISHI  
Standard output 14.0 V/40.0 A/5000 r/min  
Stator coil resistance 0.14–0.18  $\Omega$  at 20 °C (68 °F)**Rectifier/regulator**Regulator type Semi conductor-short circuit  
Model/manufacture FH012AA/SHINDENGEN  
Regulated voltage (DC) 14.2–14.8 V  
Rectifier capacity 50.0 A  
Withstand voltage 40.0 V**Battery**Model YTZ10S  
Voltage, capacity 12 V, 8.6 Ah  
Specific gravity 1.310  
Manufacturer GYM  
Ten hour rate amperage 0.90 A**Headlight**

Bulb type Halogen bulb

**Bulb voltage, wattage × quantity**Headlight 12 V, 55.0 W × 4  
Auxiliary light 12 V, 5.0 W × 2  
Tail/brake light LED  
Front turn signal light 12 V, 10.0 W × 2  
Rear turn signal light 12 V, 10.0 W × 2  
License plate light 12 V, 5.0 W × 1  
Meter lighting LED**Indicator light**Neutral indicator light LED  
Turn signal indicator light LED  
Oil level warning light LED  
High beam indicator light LED  
Fuel level warning light LED  
Coolant temperature warning light LED  
Engine trouble warning light LED  
Immobilizer system indicator light LED  
Shift timing indicator light LED

**ELECTRICAL SPECIFICATIONS****Electric starting system**

System type	Constant mesh
-------------	---------------

**Starter motor**

Model/manufacture	4C8/YAMAHA
Power output	0.90 kW
Armature coil resistance	0.0090–0.0110 $\Omega$
Brush overall length	10.8 mm (0.43 in)
Limit	7.19 mm (0.28 in)
Brush spring force	5.28–7.92 N (19.01–28.51 oz) (538–808 gf)
Commutator diameter	24.5 mm (0.96 in)
Limit	23.5 mm (0.93 in)
Mica undercut (depth)	1.50 mm (0.06 in)

**Starter relay**

Model/manufacture	2768093-A/JIDECO
Amperage	180.0 A
Coil resistance	4.18–4.62 $\Omega$

**Horn**

Horn type	Plane
Quantity	1 pcs
Model/manufacture	YF-12/NIKKO
Maximum amperage	3.0 A
Coil resistance	1.15–1.25 $\Omega$
Performance	105–113 dB/2m

**Turn signal/hazard relay**

Relay type	Full transistor
Model/manufacture	FE218BM/DENSO
Built-in, self-canceling device	No
Turn signal blinking frequency	75.0–95.0 cycles/min
Wattage	10 W $\times$ 2.0 +3.4 W

**Oil level gauge**

Model/manufacture	5VY/SOMIC ISHIKAWA
-------------------	--------------------

**Servo motor**

Model/manufacture	5VY/YAMAHA
-------------------	------------

**Fuses**

Main fuse	50.0 A
Headlight fuse	25.0 A
Signaling system fuse	7.5 A
Ignition fuse	15.0 A
Radiator fan fuse	15.0 A $\times$ 2
Turn signal light fuse	7.5 A
Backup fuse	7.5 A
Electric throttle valve fuse	7.5 A
Reserve fuse	25.0 A
Reserve fuse	15.0 A
Reserve fuse	7.5 A

## TIGHTENING TORQUES

EAS20320

### TIGHTENING TORQUES

EAS20330

#### GENERAL TIGHTENING TORQUE SPECIFICATIONS

This chart specifies tightening torques for standard fasteners with a standard ISO thread pitch. Tightening torque specifications for special components or assemblies are provided for each chapter of this manual. To avoid warpage, tighten multi-fastener assemblies in a crisscross pattern and progressive stages until the specified tightening torque is reached. Unless otherwise specified, tightening torque specifications require clean, dry threads. Components should be at room temperature.

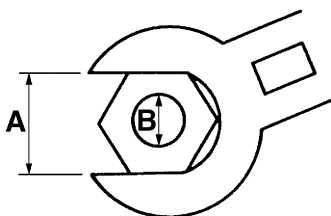

















- A. Distance between flats
- B. Outside thread diameter

A (nut)	B (bolt)	General tightening torques		
		Nm	m·kg	ft·lb
10 mm	6 mm	6	0.6	4.3
12 mm	8 mm	15	1.5	11
14 mm	10 mm	30	3.0	22
17 mm	12 mm	55	5.5	40
19 mm	14 mm	85	8.5	61
22 mm	16 mm	130	13.0	94













**TIGHTENING TORQUES**

EAS20340















**ENGINE TIGHTENING TORQUES**

Item	Thread size	Q'ty	Tightening torque	Remarks
Spark plugs	M10	4	13 Nm (1.3 m·kg, 9.4 ft·lb)	
Cylinder head nut (2pieces)	M10	2	See NOTE	
Cylinder head nut (8pieces)	M10	8	See NOTE	
Cylinder head bolt	M6	2	12 Nm (1.2 m·kg, 8.7 ft·lb)	
Camshaft cap bolt	M6	20	10 Nm (1.0 m·kg, 7.2 ft·lb)	
Cylinder head cover bolt	M6	6	12 Nm (1.2 m·kg, 8.7 ft·lb)	
Cylinder head stud bolt (exhaust pipe)	M8	8	15 Nm (1.5 m·kg, 11 ft·lb)	
Air induction system cap bolt	M6	4	10 Nm (1.0 m·kg, 7.2 ft·lb)	
Camshaft sprocket bolt	M7	4	24 Nm (2.4 m·kg, 17 ft·lb)	
Cylinder head and throttle body clamp	M6	7	10 Nm (1.0 m·kg, 7.2 ft·lb)	
Connecting rod cap bolt (1st)	M8	8	20 Nm (2.0 m·kg, 14 ft·lb)	
Connecting rod cap bolt (final)	M8	8	specified angle 150°	
Generator rotor bolt	M10	1	60 Nm (6.0 m·kg, 43 ft·lb)	
Timing chain tensioner bolt	M6	2	10 Nm (1.0 m·kg, 7.2 ft·lb)	
Water pump outlet pipe bolt	M6	1	10 Nm (1.0 m·kg, 7.2 ft·lb)	
Water pump inlet pipe bolt (water pump side)	M6	1	10 Nm (1.0 m·kg, 7.2 ft·lb)	
Water pump inlet pipe bolt (front side)	M6	1	10 Nm (1.0 m·kg, 7.2 ft·lb)	
Oil/water pump drive sprocket bolt	M6	1	15 Nm (1.5 m·kg, 11 ft·lb)	
Water pump bolt	M6	2	12 Nm (1.2 m·kg, 8.7 ft·lb)	
Thermostat cover nut	M6	2	10 Nm (1.0 m·kg, 7.2 ft·lb)	
Thermostat inlet pipe bolt	M6	1	10 Nm (1.0 m·kg, 7.2 ft·lb)	
Oil cooler bolt	M20	1	63 Nm (6.3 m·kg, 46 ft·lb)	
Engine oil drain bolt	M14	1	43 Nm (4.3 m·kg, 31 ft·lb)	
Oil pipe bolt	M6	2	10 Nm (1.0 m·kg, 7.2 ft·lb)	
Oil strainer bolt	M6	3	10 Nm (1.0 m·kg, 7.2 ft·lb)	
Oil delivery pipe bolt	M6	3	10 Nm (1.0 m·kg, 7.2 ft·lb)	
Oil filter union bolt	M20	1	70 Nm (7.0 m·kg, 51 ft·lb)	
Oil filter	M20	1	17 Nm (1.7 m·kg, 12 ft·lb)	
Oil pan bolt	M6	14	12 Nm (1.2 m·kg, 8.7 ft·lb)	
Air filter case screw	M5	9	2.0 Nm (0.2 m·kg, 1.4 ft·lb)	
Air filter case and funnel screw	M5	2	2.5 Nm (0.25 m·kg, 1.8 ft·lb)	
Throttle body and throttle body joint clamp	M5	4	3.0 Nm (0.3 m·kg, 2.2 ft·lb)	
Throttle body and funnel bolt	M6	6	6.0 Nm (0.6 m·kg, 4.3 ft·lb)	
Throttle cable adjusting bolt	M5	2	4.0 Nm (0.4 m·kg, 2.9 ft·lb)	
Cylinder head and exhaust pipe nut	M8	8	20 Nm (2.0 m·kg, 14 ft·lb)	

**TIGHTENING TORQUES**

Item	Thread size	Q'ty	Tightening torque	Remarks
Exhaust pipe and muffler bolt	M8	2	20 Nm (2.0 m·kg, 14 ft·lb)	
Exhaust pipe and EXUP valve bolt	M6	5	12 Nm (1.2 m·kg, 8.7 ft·lb)	
Exhaust valve pipe bracket bolt	M8	1	20 Nm (2.0 m·kg, 14 ft·lb)	
EXUP pulley and shaft arm nut	M6	1	6.5 Nm (0.65 m·kg, 4.7 ft·lb)	
EXUP valve pulley cover bolt	M6	2	10 Nm (1.0 m·kg, 7.2 ft·lb)	
EXUP valve and EXUP valve pipe bolt	M6	1	10 Nm (1.0 m·kg, 7.2 ft·lb)	
EXUP cable bracket bolt	M6	1	10 Nm (1.0 m·kg, 7.2 ft·lb)	
EXUP cable nut	M6	2	6.5 Nm (0.65 m·kg, 4.7 ft·lb)	
EXUP servo motor cover bolt	M5	2	2 Nm (0.2 m·kg, 1.4 ft·lb)	
EXUP servo motor bolt	M6	2	6.0 Nm (0.6 m·kg, 4.3 ft·lb)	
Catalyst pipe bracket and rear frame	M8	1	20 Nm (2.0 m·kg, 14 ft·lb)	
Catalyst pipe and EXUP valve pipe bolt	M8	1	20 Nm (2.0 m·kg, 14 ft·lb)	
Catalyst pipe and catalyst pipe bracket bolt	M8	1	20 Nm (2.0 m·kg, 14 ft·lb)	
Catalyst pipe protector	M6	4	6.5 Nm (0.65 m·kg, 4.7 ft·lb)	
Muffler and rear frame bolt	M8	2	23 Nm (2.3 m·kg, 17 ft·lb)	
Muffler protector bolt	M6	4	10 Nm (1.0 m·kg, 7.2 ft·lb)	
Crankcase stud bolt	M10	10	8.0 Nm (0.8 m·kg, 5.8 ft·lb)	
Crankcase bolt (main journal)	M9	10	See NOTE	
Crankcase bolt	M6	2	10 Nm (1.0 m·kg, 7.2 ft·lb)	
Crankcase bolt	M6	8	10 Nm (1.0 m·kg, 7.2 ft·lb)	
Crankcase bolt	M8	1	24 Nm (2.4 m·kg, 17 ft·lb)	 
Crankcase bolt	M8	5	24 Nm (2.4 m·kg, 17 ft·lb)	
Generator rotor cover bolt	M6	4	12 Nm (1.2 m·kg, 8.7 ft·lb)	
Generator rotor cover bolt	M8	3	22 Nm (2.2 m·kg, 16 ft·lb)	
Drive sprocket cover bolt	M6	3	12 Nm (1.2 m·kg, 8.7 ft·lb)	
Crankcase cover bolt	M6	3	10 Nm (1.0 m·kg, 7.2 ft·lb)	
Clutch cover bolt	M6	7	12 Nm (1.2 m·kg, 8.7 ft·lb)	
Clutch cover bolt	M6	1	12 Nm (1.2 m·kg, 8.7 ft·lb)	
Pickup rotor cover bolt	M6	6	12 Nm (1.2 m·kg, 8.7 ft·lb)	
Breather cover bolt	M6	4	12 Nm (1.2 m·kg, 8.7 ft·lb)	
Breather plate bolt	M6	3	10 Nm (1.0 m·kg, 7.2 ft·lb)	
Plate bolt	M6	1	12 Nm (1.2 m·kg, 8.7 ft·lb)	
Plate bolt	M6	1	12 Nm (1.2 m·kg, 8.7 ft·lb)	
Pickup rotor cover blind bolt	M8	1	15 Nm (1.5 m·kg, 11 ft·lb)	
Oil level plug	M20	1	1.5 Nm (0.15 m·kg, 1.1 ft·lb)	
Generator rotor cover plug	M20	1	8.0 Nm (0.8 m·kg, 5.8 ft·lb)	
Main gallery plug (oil return)	M16	3	8.0 Nm (0.8 m·kg, 5.8 ft·lb)	
Main gallery plug	M20	1	8.0 Nm (0.8 m·kg, 5.8 ft·lb)	

**TIGHTENING TORQUES**

Item	Thread size	Q'ty	Tightening torque	Remarks
Oil return pipe bolt	M6	2	10 Nm (1.0 m·kg, 7.2 ft·lb)	
Oil return plug	M12	2	24 Nm (2.4 m·kg, 17 ft·lb)	
AC magneto lead bolt	M6	1	10 Nm (1.0 m·kg, 7.2 ft·lb)	
Stator coil screw	M6	3	14 Nm (1.4 m·kg, 10 ft·lb)	
Generator rotor cover screw	M6	3	10 Nm (1.0 m·kg, 7.2 ft·lb)	
Thermostat assembly stay bolt	M6	2	10 Nm (1.0 m·kg, 7.2 ft·lb)	
Starter clutch idler gear bolt	M6	1	10 Nm (1.0 m·kg, 7.2 ft·lb)	
Clutch boss nut	M20	1	115 Nm (11.5 m·kg, 83 ft·lb)	 Use a lock washer
Clutch spring bolt	M6	6	10 Nm (1.0 m·kg, 7.2 ft·lb)	
Drive sprocket nut	M22	1	85 Nm (8.5 m·kg, 61 ft·lb)	 Use a lock washer
Bearing plate bolt	M6	3	12 Nm (1.2 m·kg, 8.7 ft·lb)	
Shift bar stopper plate bolt	M6	2	10 Nm (1.0 m·kg, 7.2 ft·lb)	
Stopper screw	M8	1	22 Nm (2.2 m·kg, 16 ft·lb)	
Shift rod nut	M6	1	6.5 Nm (0.65 m·kg, 4.7 ft·lb)	Left thread
Shift rod nut	M6	1	6.5 Nm (0.65 m·kg, 4.7 ft·lb)	
Joint rod bolt	M6	1	10 Nm (1.0 m·kg, 7.2 ft·lb)	
Shift arm bolt	M6	1	10 Nm (1.0 m·kg, 7.2 ft·lb)	
Neutral switch	M10	1	20 Nm (2.0 m·kg, 14 ft·lb)	
Coolant temperature sensor	M12	1	18 Nm (1.8 m·kg, 13 ft·lb)	
Cylinder identification sensor bolt	M6	1	8.0 Nm (0.8 m·kg, 5.8 ft·lb)	
Atmospheric pressure sensor screw	M5	2	7.0 Nm (0.7 m·kg, 5.0 ft·lb)	
Crankshaft position sensor bolt	M6	1	10 Nm (1.0 m·kg, 7.2 ft·lb)	
Oil level switch bolt	M6	2	10 Nm (1.0 m·kg, 7.2 ft·lb)	

**NOTE:**

- Cylinder head nut (2 pieces)
  1. First, tighten the bolts to 10 Nm (1.0 m·kg, 7.2 ft·lb) with a torque wrench following the tightening order.
  2. Second, tighten the bolts to 25 Nm (2.5 m·kg, 18 ft·lb) with a torque wrench following the tightening order.
  3. Third, tighten the bolts to 40 Nm (4.0 m·kg, 29 ft·lb) with a torque wrench following the tightening order.
  4. Final, tighten the bolts to 55 Nm (5.5 m·kg, 40 ft·lb) with a torque wrench following the tightening order.
- Cylinder head nut (8 pieces)
  1. First, tighten the bolts to 10 Nm (1.0 m·kg, 7.2 ft·lb) with a torque wrench following the tightening order.
  2. Second, tighten the bolts to 25 Nm (2.5 m·kg, 18 ft·lb) with a torque wrench following the tightening order.

## TIGHTENING TORQUES

3. Final, tighten the bolts to 40 Nm (4.0 m·kg, 29 ft·lb) with a torque wrench following the tightening order.
- Crankcase bolt (main journal)
    1. First, tighten the bolts to approximately 20 Nm (2.0 m·kg, 14 ft·lb) with a torque wrench following the tightening order.
    2. Loosen all the bolts one by one following the tightening order and then tighten them to 20 Nm (2.7 m·kg, 14 ft·lb) again.
    3. Retighten the bolts further to reach the specified angle (56-61°).

### Cylinder head tightening sequence:

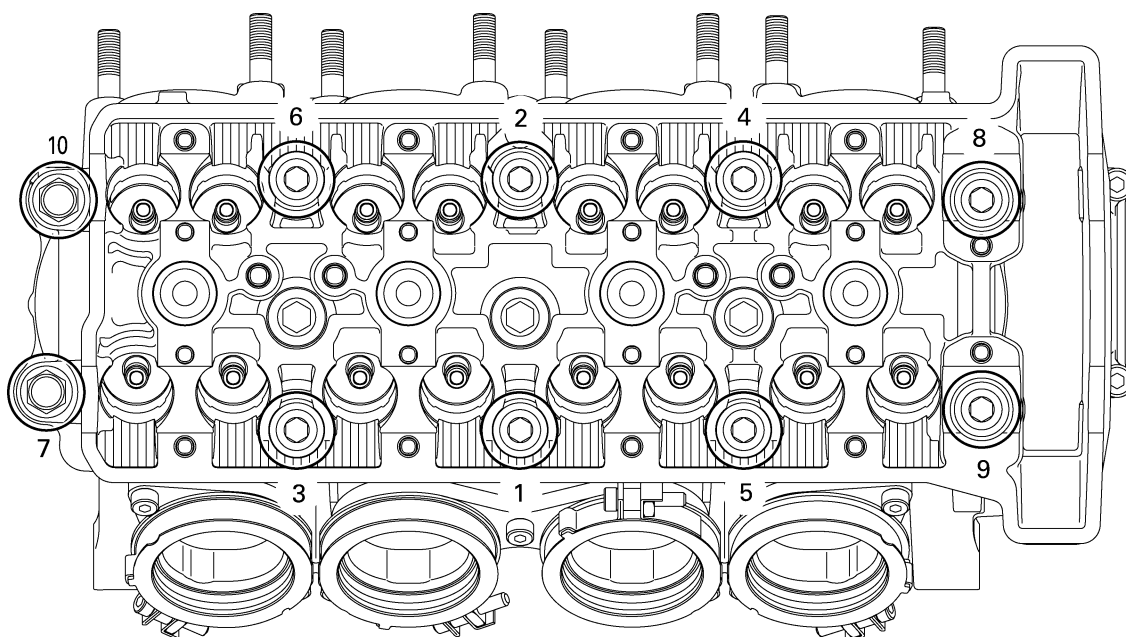



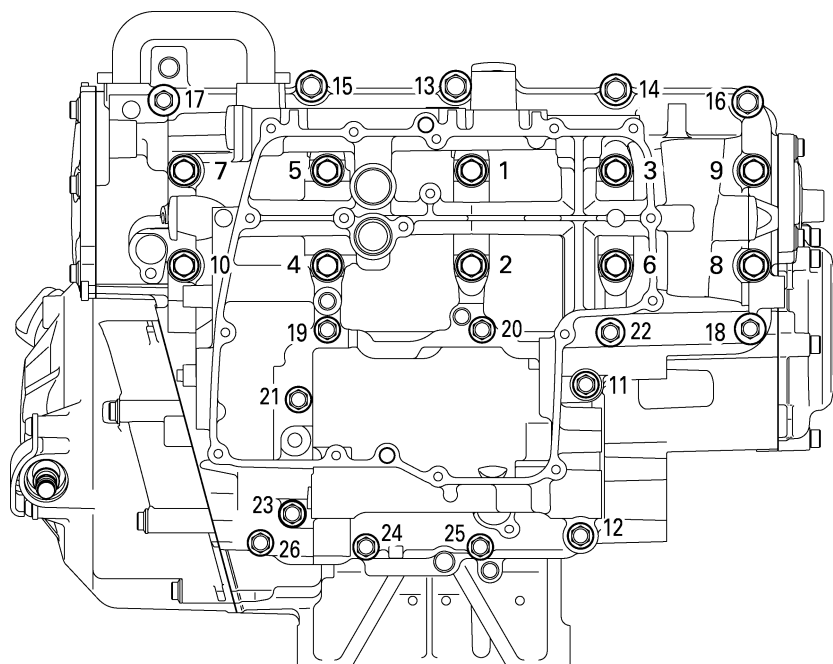

### Crankcase tightening sequence:





**TIGHTENING TORQUES**

EAS20350

**CHASSIS TIGHTENING TORQUES**

Item	Thread size	Q'ty	Tightening torque	Remarks
Upper bracket pinch bolt	M8	2	26 Nm (2.6 m·kg, 19 ft·lb)	
Steering stem nut	M28	1	113 Nm (11.3 m·kg, 82 ft·lb)	
Handlebar pinch bolt	M8	2	17 Nm (1.7m·kg, 12 ft·lb)	
Handlebar bolt	M6	2	13 Nm (1.3 m·kg, 9.4 ft·lb)	
Cap bolt	M46	2	23 Nm (2.3 m·kg, 17 ft·lb)	
Lower ring nut	M30	2	See NOTE	
Lower bracket pinch bolt	M8	4	23 Nm (2.3 m·kg, 17 ft·lb)	
Brake master cylinder reservoir cap screw	M4	1	1.2 Nm (0.12 m·kg, 0.9 ft·lb)	
Front brake hose union bolt	M10	3	30 Nm (3.0 m·kg, 22 ft·lb)	
Front brake master cylinder holder bolt	M6	2	13 Nm (1.3 m·kg, 9.4 ft·lb)	
Meter assembly and cowling stay screw	–	3	1.3 Nm (0.13 m·kg, 0.9 ft·lb)	
Headlight and cowling stay screw	–	6	0.8 Nm (0.08 m·kg, 0.6 ft·lb)	
Front cowling and headlight screw	–	5	1.5 Nm (0.15 m·kg, 1.1 ft·lb)	
Side cowling bracket and frame bolt	M6	2	5.0 Nm (0.5 m·kg, 3.6 ft·lb)	
Under cowling and engine bolt	M6	3	5.0 Nm (0.5 m·kg, 3.6 ft·lb)	
Rear view mirror nut	M6	4	7.0 Nm (0.7 m·kg, 5.1 ft·lb)	
Front cowling and intake air duct panel screw	M5	2	1.3 Nm (0.13 m·kg, 0.9 ft·lb)	
Grip end bolt	M6	2	4.0 Nm (0.4 m·kg, 2.9 ft·lb)	
Horn bracket bolt	M6	2	11 Nm (1.1 m·kg, 8.0 ft·lb)	
Coolant reservoir bolt	M6	2	5.0 Nm (0.5 m·kg, 3.6 ft·lb)	
Left front engine mounting bolt	M10	1	45 Nm (4.5 m·kg, 33 ft·lb)	
Right front engine mounting bolt	M10	1	45 Nm (4.5 m·kg, 33 ft·lb)	
Engine mount self locking nut (upper)	M10	1	51 Nm (5.1 m·kg, 37 ft·lb)	See NOTE 
Engine mount self locking nut (lower)	M10	1	51 Nm (5.1 m·kg, 37 ft·lb)	See NOTE 
Engine mounting adjust bolt (upper)	M16	1	7.0 Nm (0.7 m·kg, 5.1 ft·lb)	See NOTE
Engine mounting adjust bolt (lower)	M16	1	7.0 Nm (0.7 m·kg, 5.1 ft·lb)	See NOTE
Clutch cable locknut (engine side)	M8	1	7.0 Nm (0.7 m·kg, 5.1 ft·lb)	
Main frame and rear frame bolt	M10	4	50 Nm (5.0 m·kg, 36 ft·lb)	See NOTE 
Pivot shaft	M30	1	7.0 Nm (0.7 m·kg, 5.1 ft·lb)	
Pivot shaft ring nut	M30	1	65 Nm (6.5 m·kg, 47 ft·lb)	
Pivot shaft nut	M20	1	105 Nm (10.5 m·kg, 76 ft·lb)	

**TIGHTENING TORQUES**

Item	Thread size	Q'ty	Tightening torque	Remarks
Connecting arm nut (connecting arm and frame)	M10	1	44 Nm (4.4 m·kg, 32 ft·lb)	
Relay arm nut (relay arm and connecting arm)	M10	1	44 Nm (4.4 m·kg, 32 ft·lb)	
Relay arm nut (relay arm and swingarm)	M10	1	44 Nm (4.4 m·kg, 32 ft·lb)	
Rear shock absorber assembly lower nut	M10	1	44 Nm (4.4 m·kg, 32 ft·lb)	
Rear shock absorber upper bracket nut	M10	1	44 Nm (4.4 m·kg, 32 ft·lb)	
Rear shock absorber assembly upper nut	M10	1	92 Nm (9.2 m·kg, 67 ft·lb)	
Drive chain guard bolt	M6	2	7.0 Nm (0.7 m·kg, 5.1 ft·lb)	
Drive chain guide bolt	M6	1	13 Nm (1.3 m·kg, 9.4 ft·lb)	
Drive chain adjusting locknut	M8	2	16 Nm (1.6 m·kg, 12 ft·lb)	
Fuel pump bolt	M5	6	4.0 Nm (0.4 m·kg, 2.9 ft·lb)	
Fuel tank bolt (front)	M6	1	7.0 Nm (0.7 m·kg, 5.1 ft·lb)	
Fuel tank bracket bolt	M6	2	7.0 Nm (0.7 m·kg, 5.1 ft·lb)	
Fuel tank bolt (rear)	M6	4	7.0 Nm (0.7 m·kg, 5.1 ft·lb)	
Fuel tank side cover screw	M5	2	4.0 Nm (0.4 m·kg, 2.9 ft·lb)	
Rider seat bolt	M6	2	7.0 Nm (0.7 m·kg, 5.1 ft·lb)	
Seat lock assembly bolt	M6	2	10 Nm (1.0 m·kg, 7.2 ft·lb)	
Upper tail cover bolt	M5	1	4.0 Nm (0.4 m·kg, 2.9 ft·lb)	
Battery box bolt	M6	2	7.0 Nm (0.7 m·kg, 5.1 ft·lb)	
Lean angle sensor bolt	M4	2	2.0 Nm (0.2 m·kg, 1.4 ft·lb)	
Footrest bracket bolt	M8	4	28 Nm (2.8 m·kg, 20 ft·lb)	
Rear brake master cylinder bolt	M8	2	23 Nm (2.3 m·kg, 17 ft·lb)	
Rear brake hose union bolt	M10	2	30 Nm (3.0 m·kg, 22 ft·lb)	
Sidestand and bracket nut	M10	1	61 Nm (6.1 m·kg, 44 ft·lb)	
Sidestand bracket and frame bolt	M10	2	63 Nm (6.3 m·kg, 46 ft·lb)	
Front wheel axle bolt	M14	1	91 Nm (9.1 m·kg, 66 ft·lb)	
Rear wheel axle nut	M24	1	150 Nm (15.0 m·kg, 108 ft·lb)	
Front brake caliper bolt	M10	4	35 Nm (3.5 m·kg, 25 ft·lb)	
Front brake disc bolt	M6	10	18 Nm (1.8 m·kg, 13 ft·lb)	
Rear brake disc bolt	M8	5	30 Nm (3.0 m·kg, 22 ft·lb)	
Rear wheel sprocket nut	M10	6	100 Nm (10.0 m·kg, 72 ft·lb)	
Brake caliper bleed screw	M8	3	6.0 Nm (0.6 m·kg, 4.3 ft·lb)	
Front wheel axle pinch bolt	M8	4	21 Nm (2.1 m·kg, 15 ft·lb)	See NOTE

**NOTE:**

- Lower ring nut
  1. First, tighten the lower ring nut approximately 52 Nm (5.2 m·kg, 38 ft·lb) by using the torque wrench, then loosen the ring nut completely.
  2. Retighten the lower ring nut 18 Nm (1.8 m·kg, 13 ft·lb).
- Engine mounting adjust bolt and engine mount self locking nut  
Refer to "INSTALLING THE ENGINE" on page 5-7.

## TIGHTENING TORQUES

• Front wheel axle pinch bolt

1. Insert the front wheel axle from the right side and tighten it with the flange bolt from the left side to 91 Nm (9.1 m·kg, 65.8 ft·lb).
2. In the order from the pinch bolt “2” → pinch bolt “1” → pinch bolt “2”, tighten each bolt to 21 Nm (2.1 m·kg, 15 ft·lb) without performing temporary tightening.
3. Check that the end face of the axle head and the end face of the fork side are flush-mounted. If they are out of alignment, make sure to fit them by adding the external force by hand or with a plastic hammer, etc.  
If the end face of the axle is not parallel to the end face of the fork, align them so that one point of the axle circumference is positioned on the end face of the fork.  
At this stage, it can be accepted if the end face of the axle becomes partially concave to the end face of the fork.
4. In the order from the pinch bolt “4” → pinch bolt “3” → pinch bolt “4”, tighten each bolt to 21 Nm (2.1 m·kg, 15 ft·lb) without performing temporary tightening.

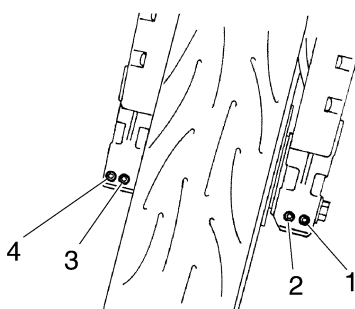

• Main frame and rear frame bolt

1. Check the clearance between rear frame and main frame by thickness gauge “1”. Insert adjusting shim(s) to eliminate the gap according to the chart as shown below.

Thickness	Shim(s)
Under 0.5 mm (Under 0.01969 in)	NONE
0.51–1.0 mm (0.02008–0.03937 in)	One shim on the left side
1.01–1.5 mm (0.03976–0.05906 in)	Two shims on the left side
1.51–2.0 mm (0.05945–0.07874 in)	Three shims on the left side
2.01–2.5 mm (0.07913–0.09843 in)	Three shims on the left side and one shim on the right side
2.51–3.0 mm (0.09882–0.11811 in)	Three shims on the left side and two shims on the right side

Shim: 0.5 mm (0.02 in)

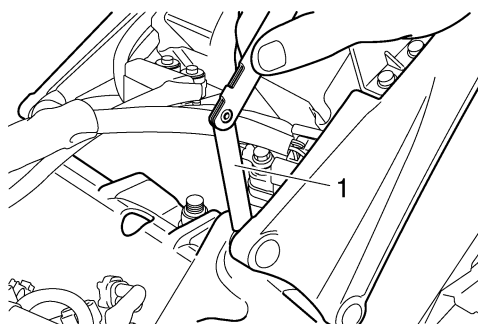

























## LUBRICATION POINTS AND LUBRICANT TYPES

EAS20360

### LUBRICATION POINTS AND LUBRICANT TYPES





















EAS20370

#### ENGINE

Lubrication point	Lubricant
Oil seal lips	
O-rings	
Bearings	
Crankshaft pins	
Piston surfaces	
Piston pins	
Connecting rod bolts	
Crankshaft journals	
Camshaft lobes	
Camshaft journals	
Valve stems (intake and exhaust)	
Valve stem ends (intake and exhaust)	
Water pump impeller shaft	
Oil pump rotors (inner and outer)	
Oil pump housing	
Oil strainer	
Clutch (pull rod)	
Starter clutch idle gear inner surface	
Starter clutch assembly	
Primary driven gear	
Transmission gears (wheel and pinion)	
Main axle and drive axle	
Shift drum	
Shift forks and shift fork guide bars	
Cylinder head cover mating surface	Yamaha bond No. 1215
Cylinder head cover semicircular	Yamaha bond No. 1215
Crankcase mating surface	Yamaha bond No. 1215
Crankcase cover mating surface	Yamaha bond No. 1215
Generator rotor cover (stator coil assembly lead grommet)	Yamaha bond No. 1215

## LUBRICATION POINTS AND LUBRICANT TYPES

EAS20380  
**CHASSIS**

Lubrication point	Lubricant
Steering bearings and bearing races (upper and lower)	
Throttle grip inner surface	
Brake lever pivoting point and metal-to-metal moving parts	
Clutch lever pivoting point and metal-to-metal moving parts	
Engine mount bolts (rear upper and lower)	
Relay arm, connecting rod and rear shock absorber collar	
Pivot shaft	
Swingarm pivot bearing	
Swingarm head pipe end, oil seal and bush	
Oil seal (relay arm, connecting arm and rear shock absorber)	
Seat lock assembly moving parts	
Sidestand pivoting pint and metal-to-metal moving parts	
Link and sidestand switch contact point	
Sidestand hook and spring	
Shift shaft joint	
Front wheel oil seal (right and left)	
Front axle shaft	
Rear wheel oil seal	
Rear wheel drive hub oil seal	
Rear wheel drive hub mating surface	

# LUBRICATION SYSTEM CHART AND DIAGRAMS

EAS20390

## LUBRICATION SYSTEM CHART AND DIAGRAMS

EAS20400

### ENGINE OIL LUBRICATION CHART

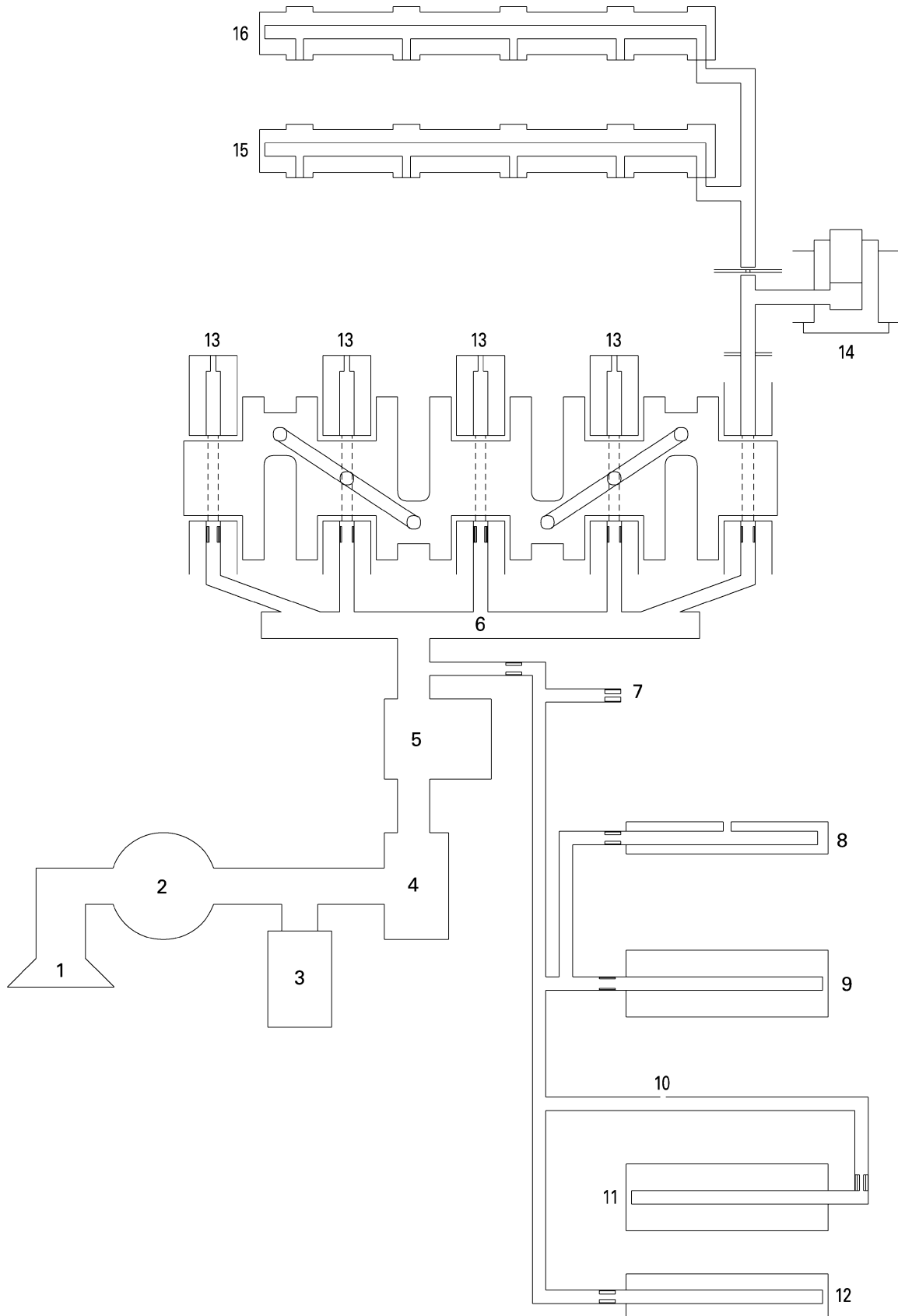

## LUBRICATION SYSTEM CHART AND DIAGRAMS

---

1. Oil strainer
2. Oil pump
3. Relief valve
4. Oil cooler
5. Oil filter
6. Main gallery
7. AC magneto drive gear shower
8. Shift fork (upper)
9. Main axle
10. Mission shower
11. Drive axle
12. AC magneto axle
13. Piston cooler
14. Chain tensioner
15. Intake camshaft
16. Exhaust camshaft

# LUBRICATION SYSTEM CHART AND DIAGRAMS

EAS20410

## LUBRICATION DIAGRAMS

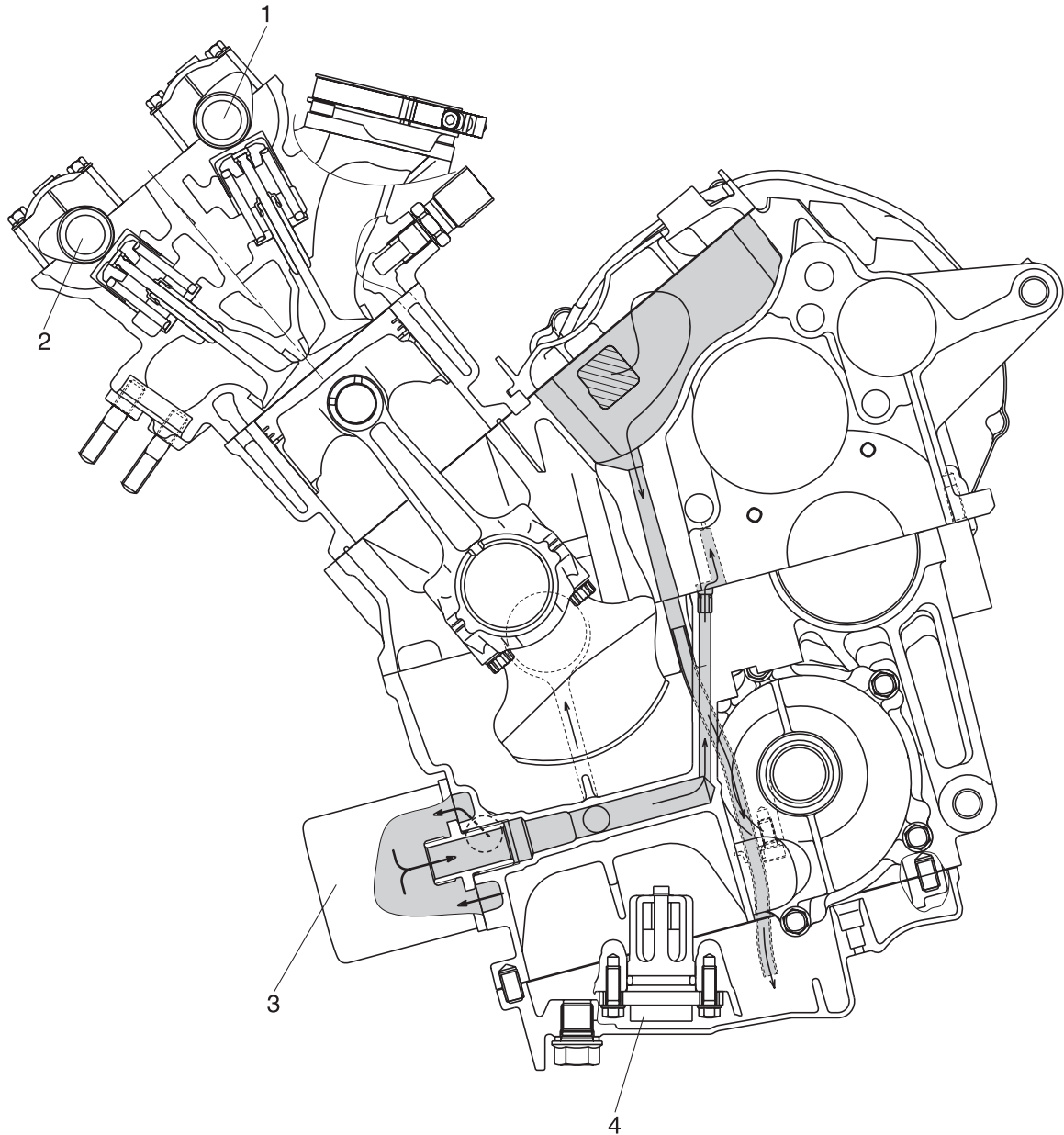

## LUBRICATION SYSTEM CHART AND DIAGRAMS

---

1. Intake camshaft
2. Exhaust camshaft
3. Oil filter cartridge
4. Oil level switch

# LUBRICATION SYSTEM CHART AND DIAGRAMS

---

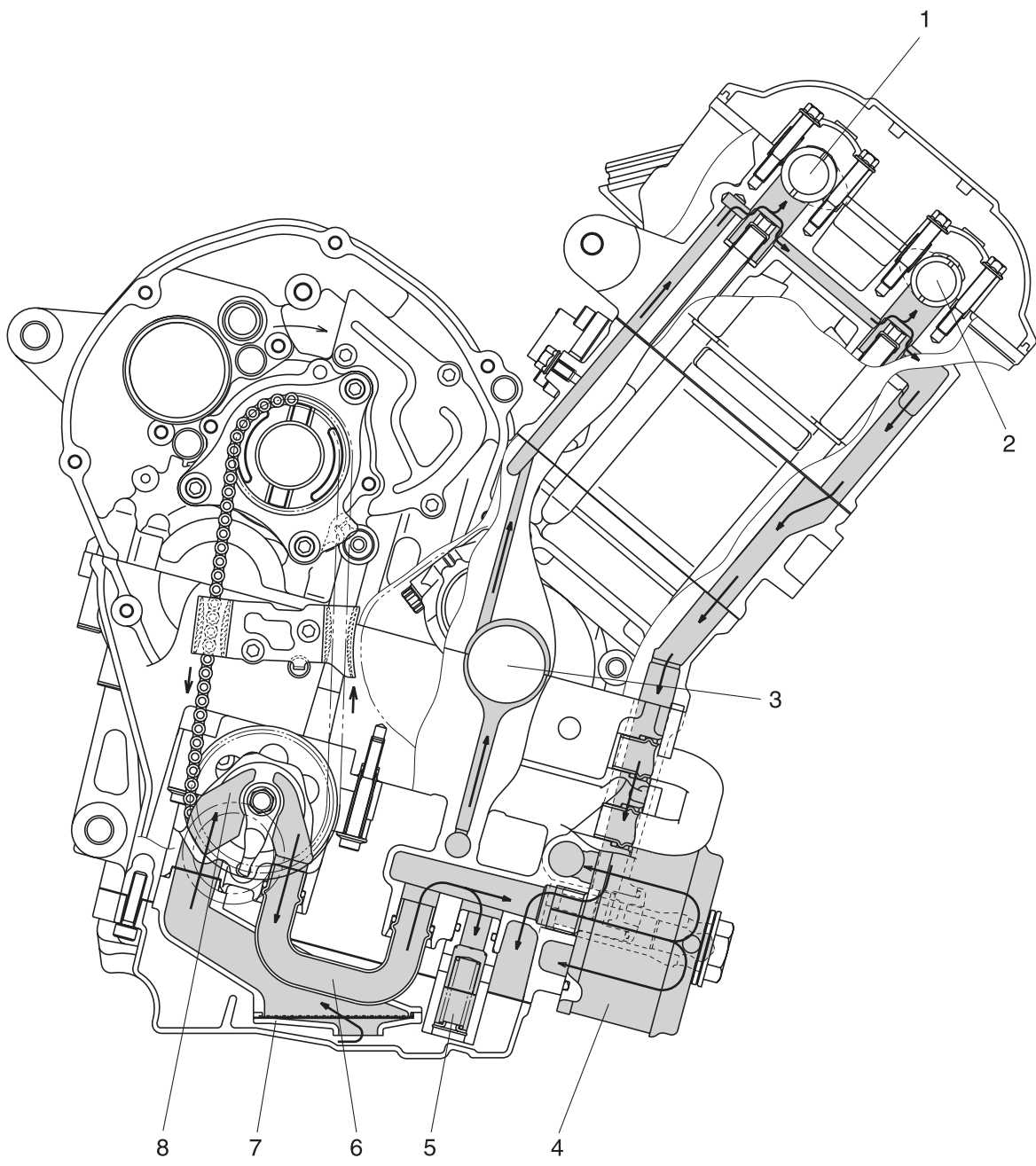

## LUBRICATION SYSTEM CHART AND DIAGRAMS

---

1. Intake camshaft
2. Exhaust camshaft
3. Crankshaft
4. Oil cooler
5. Relief valve
6. Oil pipe
7. Oil strainer
8. Oil pump

## LUBRICATION SYSTEM CHART AND DIAGRAMS

---

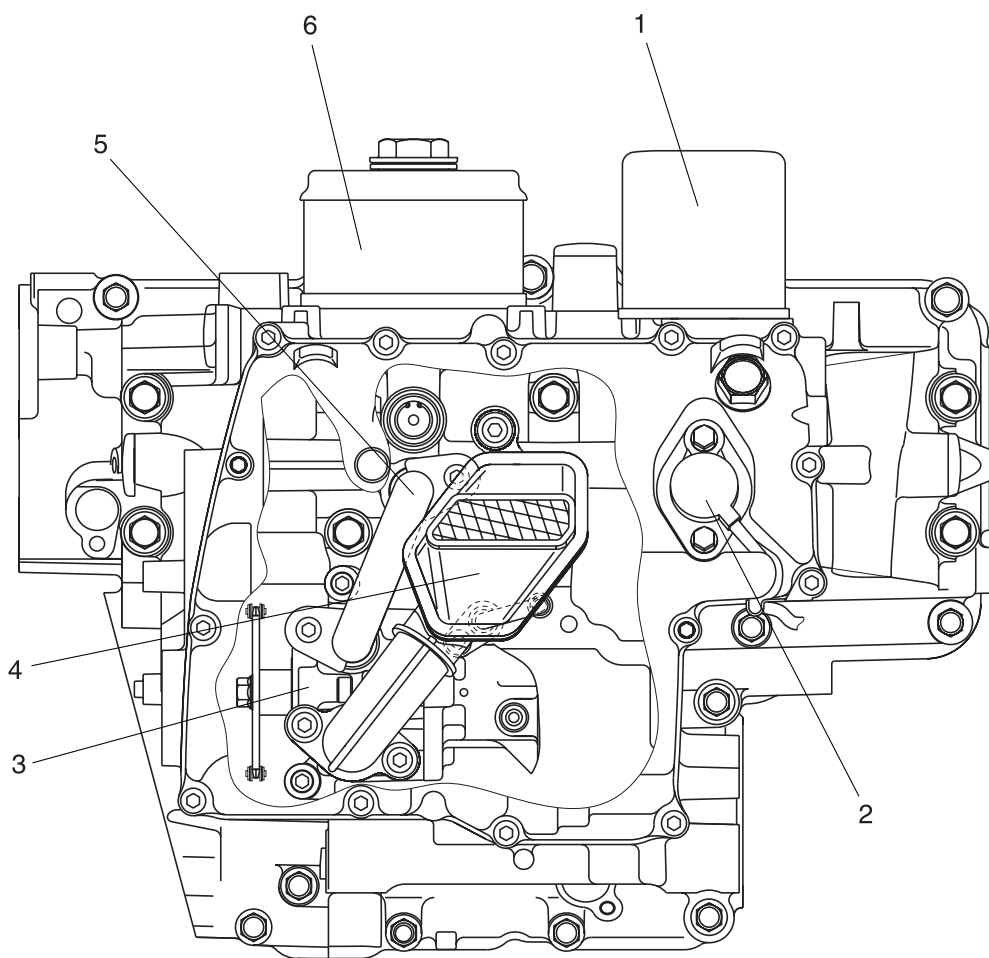

## LUBRICATION SYSTEM CHART AND DIAGRAMS

---

1. Oil filter cartridge
2. Oil level switch
3. Oil pump
4. Oil strainer
5. Oil pipe
6. Oil cooler

# LUBRICATION SYSTEM CHART AND DIAGRAMS

---

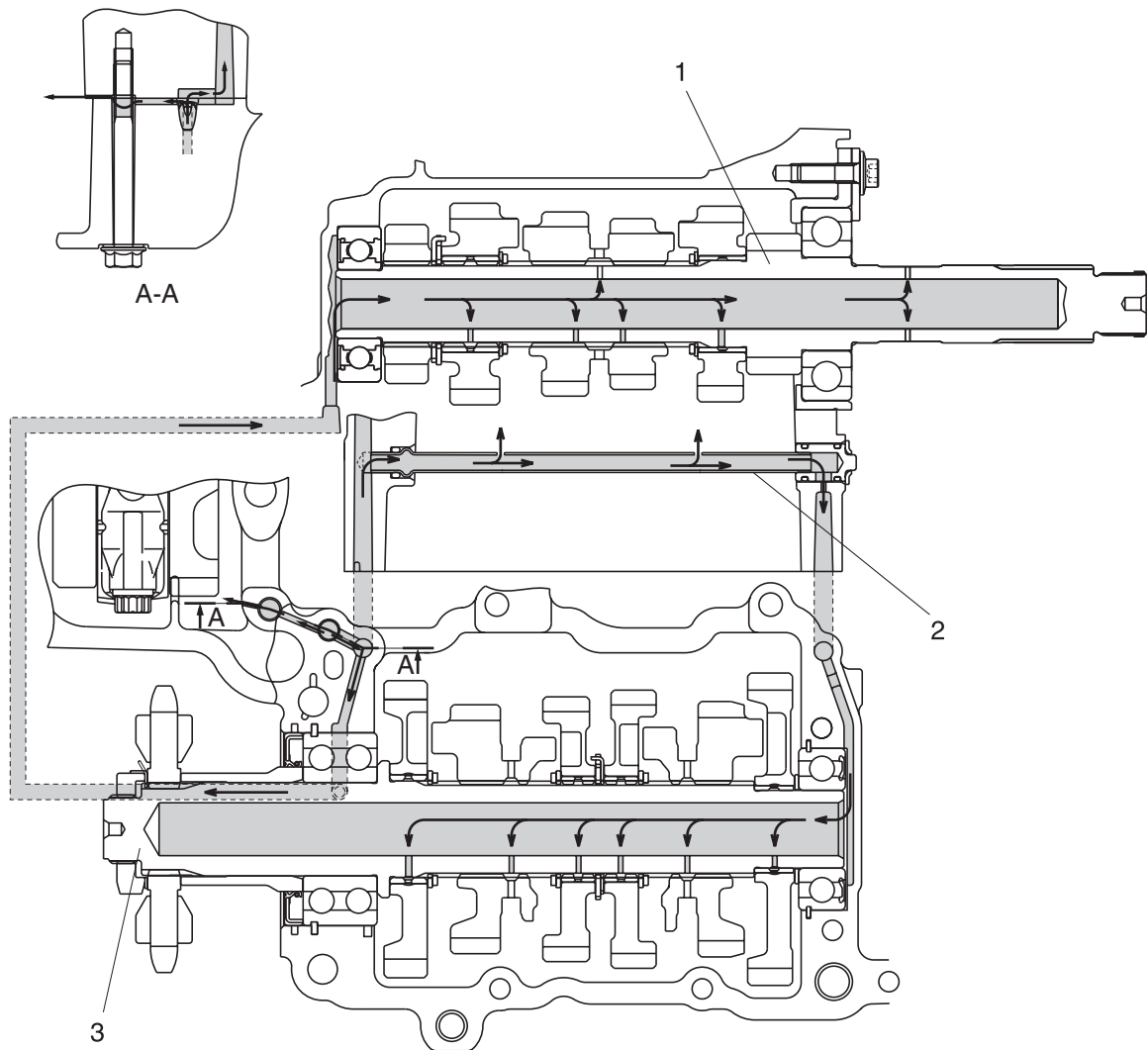

## LUBRICATION SYSTEM CHART AND DIAGRAMS

---

1. Main axle
2. Oil delivery pipe
3. Drive axle

# LUBRICATION SYSTEM CHART AND DIAGRAMS

---

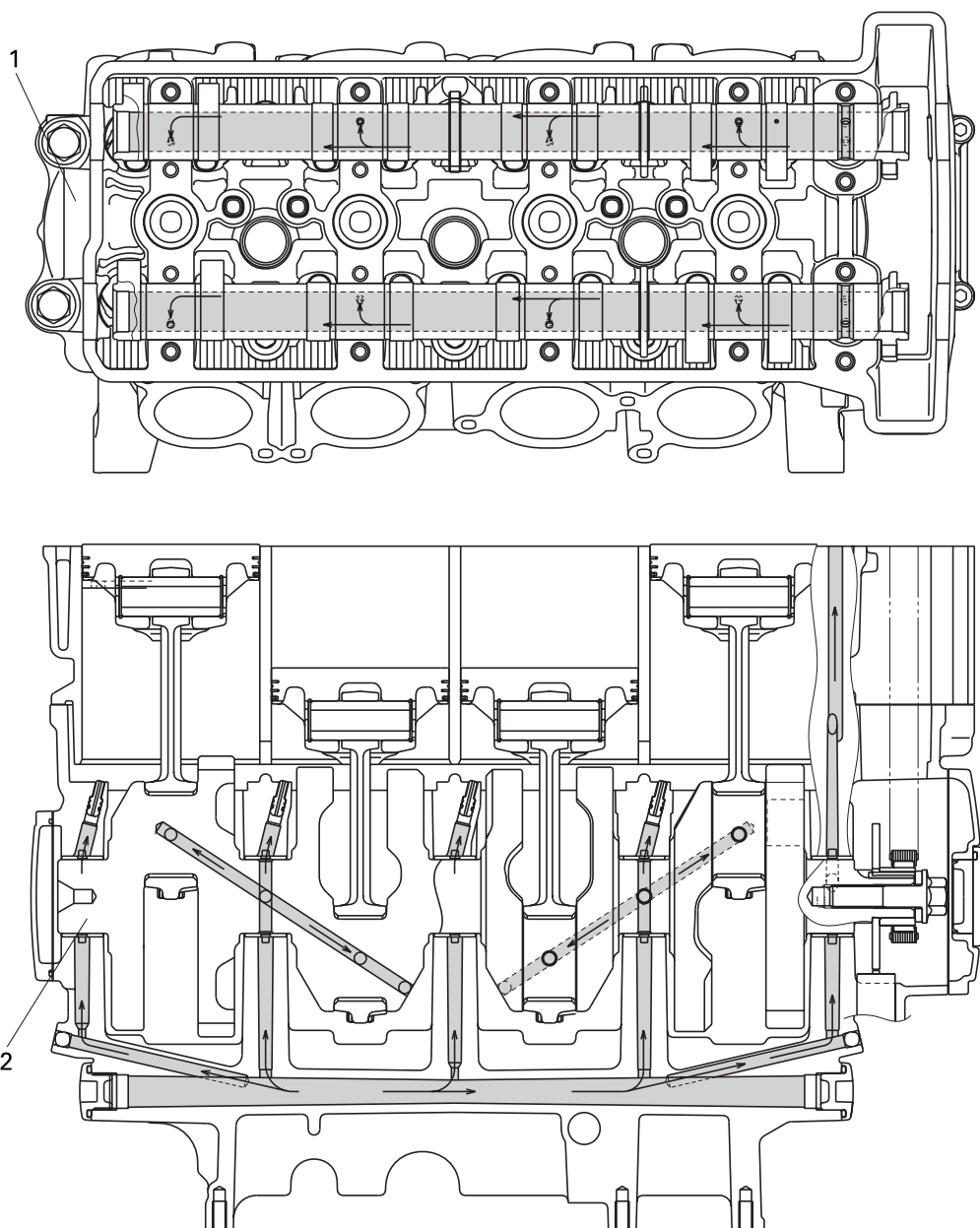

## LUBRICATION SYSTEM CHART AND DIAGRAMS

---

1. Cylinder head
2. Crankshaft

# COOLING SYSTEM DIAGRAMS

EAS20420

## COOLING SYSTEM DIAGRAMS

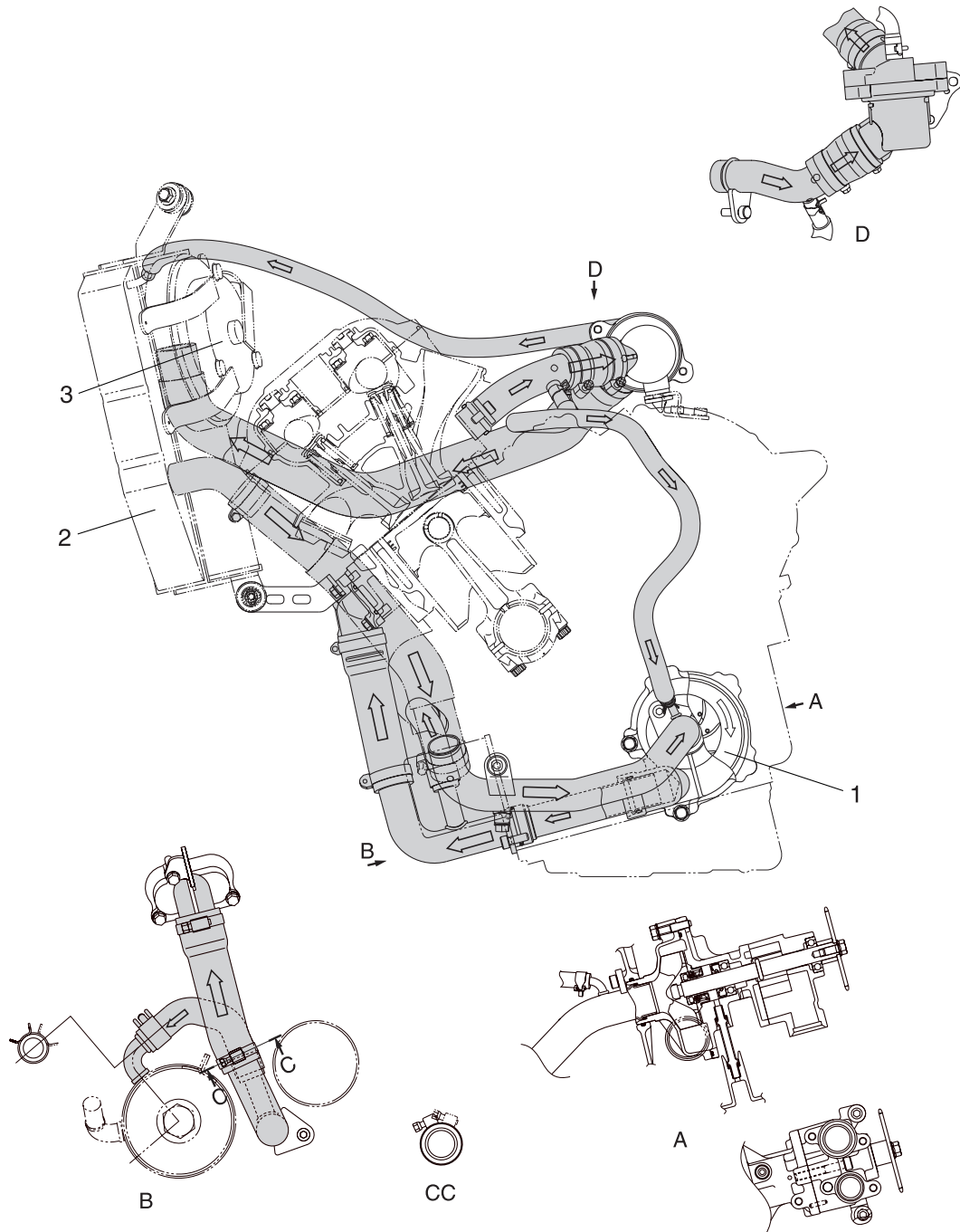

## **COOLING SYSTEM DIAGRAMS**

---

1. Water pump
2. Radiator
3. Radiator fan

## COOLING SYSTEM DIAGRAMS

---

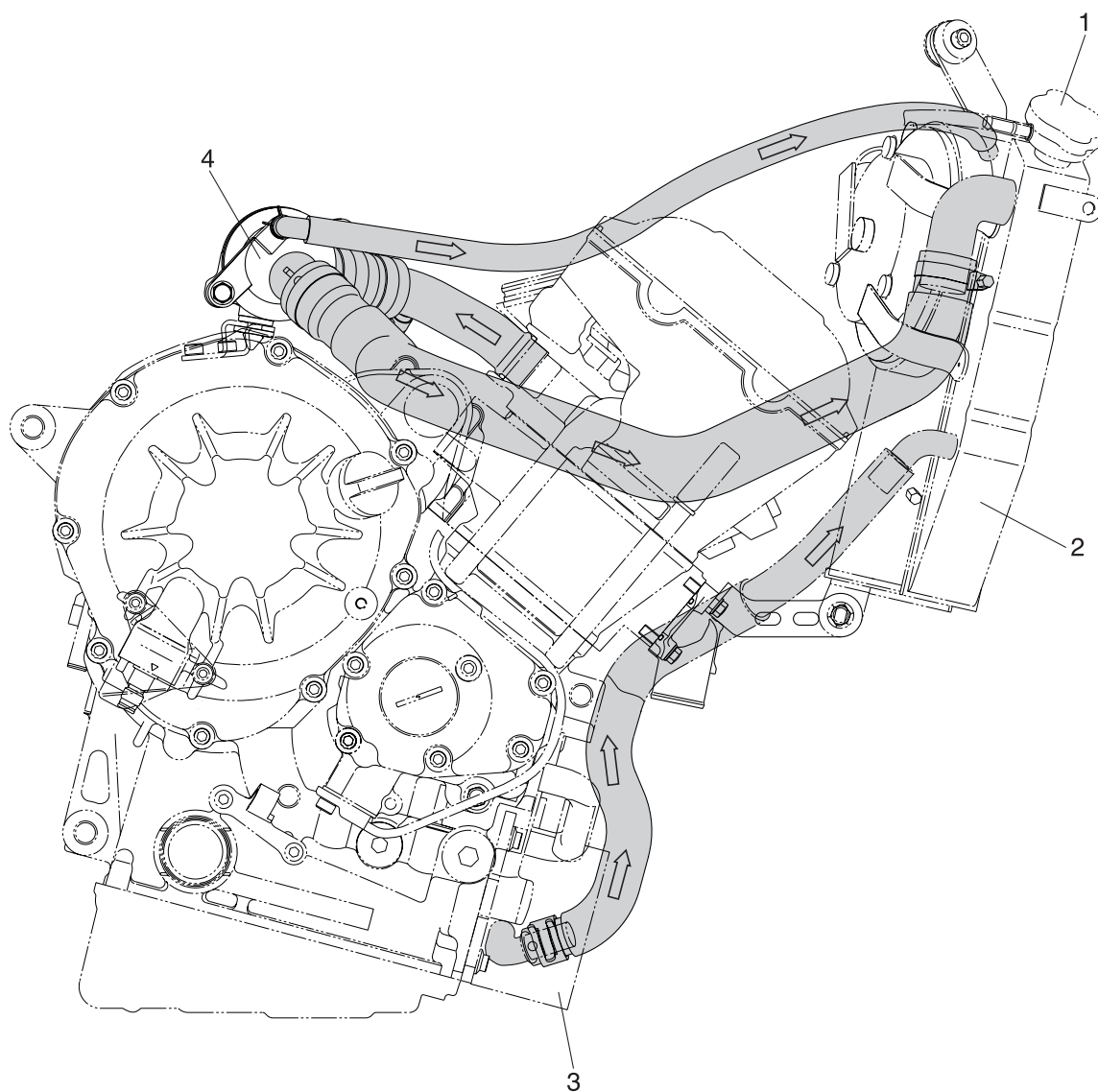

## COOLING SYSTEM DIAGRAMS

---

1. Radiator cap
2. Radiator
3. Oil cooler
4. Thermostat

# CABLE ROUTING

EAS20430

## CABLE ROUTING

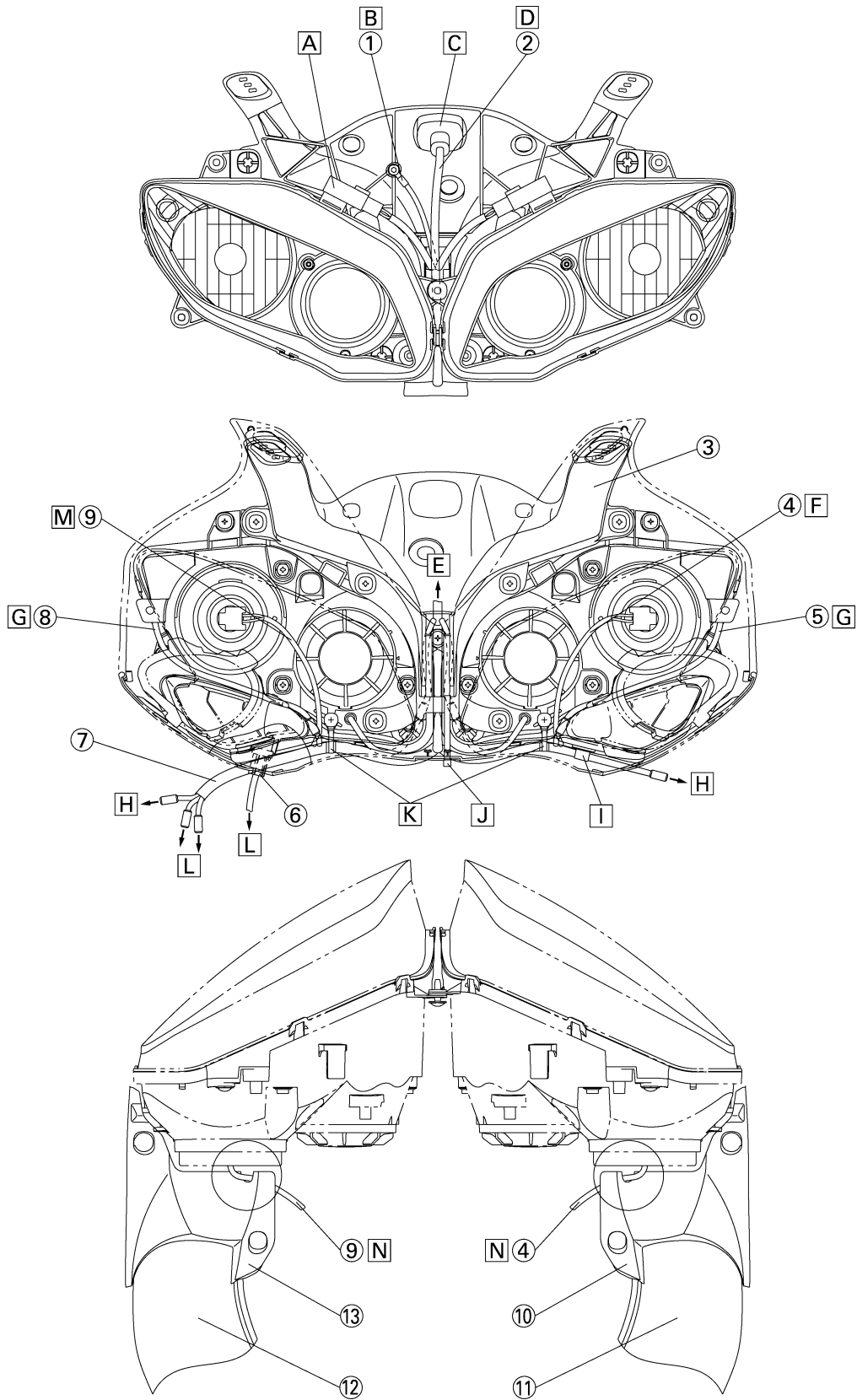

## CABLE ROUTING

---

1. Ground lead
  2. Meter lead
  3. Headlight stay
  4. Right headlight lead (high beam)
  5. Right auxiliary light lead
  6. Intake air temperature sensor coupler
  7. Headlight lead
  8. Left auxiliary light lead
  9. Left headlight lead (high beam)
  10. Right console panel
  11. Right intake air duct
  12. Left intake air duct
  13. Left console panel
- A. Insert to the rib of the head light.  
(Either location of the right and left relays is acceptable.)
  - B. The lead should not stretch too much.  
Direction of the ground terminal can be either top side or flip side.
  - C. Make sure to insert the coupler and boot to the stay hole.
  - D. The speedometer lead should not be strained.
  - E. To the headlight stay hole
  - F. Route by the rear side of the vehicle away from the right auxiliary light lead.
  - G. Connect after passing over the upper side of the duct.
  - H. To the turn signal light
  - I. Paste the latch of the clamp to be positioned toward the rear side of the vehicle.
  - J. There should be no slack when clamping.  
Point the tip of the clamp (excessive part) to the front side of the vehicle.  
Fasten the headlight lead with a clamp.
  - K. Clamp the headlight lead.  
Cut the tip of the clamp.
  - L. To the wire harness
  - M. Route by the rear side of the vehicle away from the left auxiliary light lead.
  - N. Feed a lead wire through the U shape cut-out of the console panel.

# CABLE ROUTING

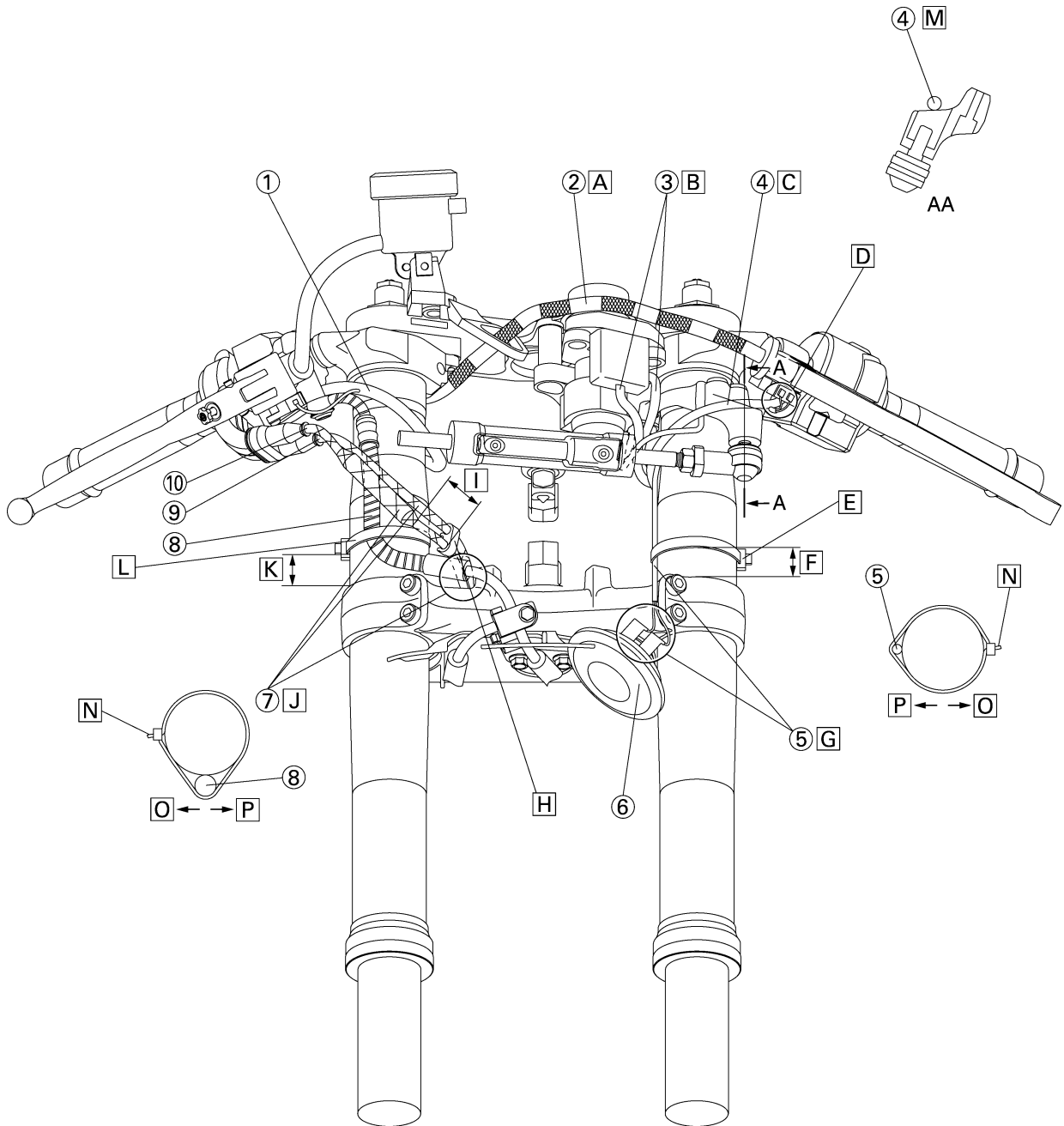

## CABLE ROUTING

---

1. Right handlebar switch lead
  2. Clutch cable
  3. Main switch lead
  4. Left handlebar switch lead
  5. Horn lead
  6. Horn
  7. Throttle cables
  8. Brake hose
  9. Throttle cable (return side)
  10. Throttle cable (pull side)
- A. Route the clutch cable so as to get along the front side of the main switch after passing it through the guide.
  - B. Pass the main switch lead through the guide wire.
  - C. Pass the left handlebar switch lead through the guide wire.
  - D. Pass the clutch switch lead through outside of the left handlebar switch lead.
  - E. Point the tip of the band (excessive part) to the left side of the vehicle and cut the surplus section.
  - F. Clamp the section between 0 and 20 mm (0 and 0.79 in) from the split of the under bracket.
  - G. Clamp the leads inside the front fork of the vehicle. Point the exit of the horn lead to the left front fork side.
  - H. Fit in the clamp from the inner side to the outer side of the vehicle so that the return side is positioned upper and the pull side is lower at the upper side of the vehicle above the brake hose.
  - I. 0 to 30 mm (0 to 1.18 in)
  - J. Route two throttle cables behind the brake hose, pass between the inside of the under bracket's upper side front fork.
  - K. 20 to 40 mm (0.8 to 1.6 in)
  - L. Point the tip of the band (excessive part) to the right side of the vehicle and cut the surplus section.
  - M. Pass the left handlebar switch lead through upper side of the steering damper bracket.
  - N. Cut the clamp tip leaving 2 to 4 mm (0.08 to 0.16 in).
  - O. Outside of the vehicle.
  - P. Inside of the vehicle.

# CABLE ROUTING

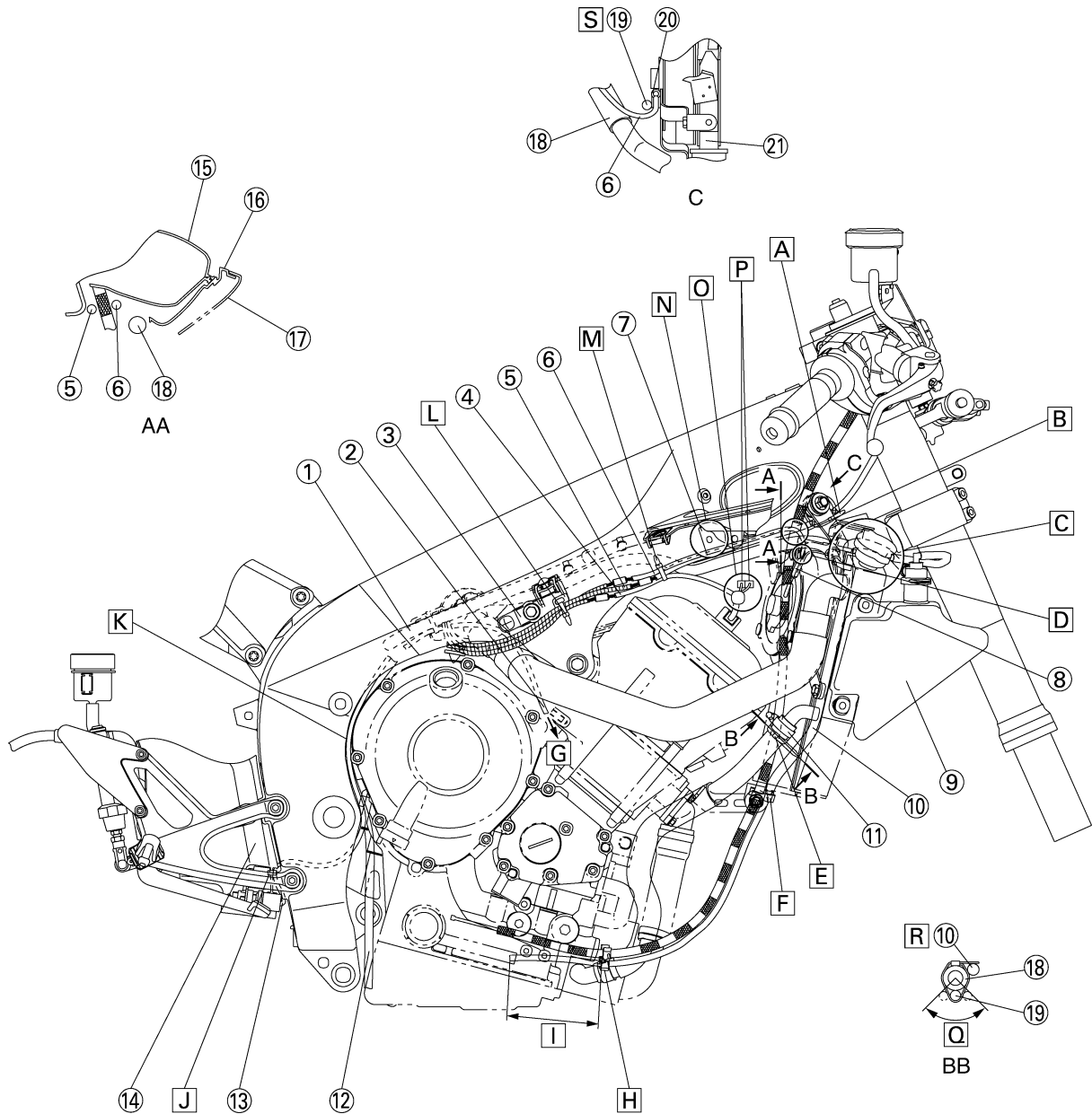

## CABLE ROUTING

1. Wire harness
  2. Crankshaft position sensor lead
  3. Bracket
  4. Ignition coil lead
  5. Right handlebar switch lead
  6. Radiator fan motor lead
  7. Heat protector
  8. Right radiator fan motor lead
  9. Coolant reservoir tank
  10. Coolant reservoir drain hose
  11. Hose clamp
  12. O<sub>2</sub> sensor lead
  13. Rear brake light switch
  14. Protector
  15. Right intake air duct
  16. Right air outlet grille
  17. Cover
  18. Water hose
  19. Clutch cable
  20. Radiator stay guide
  21. Radiator
- A. Clamp it after passing between the frame and radiator stay.  
Align the clamp position with the taping sections of right handlebar switch lead. Point the tip of the clamp (excessive part) to the front side of the vehicle. Fasten the right handlebar switch lead with a clamp.
  - B. Pass the clutch cable through inside of the water hose.  
Route the radiator fan motor lead by the outside of the clutch cable after routing it by the inner side of the water hose.
  - C. Route the coolant reservoir drain hose by the outside of the water hose after routing it by the inner side of the radiator cap mounting section.
  - D. Check that the radiator fan motor lead is fixed with the guide of the radiator stay.
  - E. Clamp so that the clamp top end is set along with the bottom end of the hose clamp.  
Point the tip of the clamp (excessive part) to the front side of the vehicle. Fasten the clutch cable with a clamp.
  - F. Clamp so that the coolant reservoir drain hose is positioned at the front side of the vehicle by aligning the protector end part of the coolant reservoir drain hose with the radiator bottom end.  
Fasten the clutch cable and coolant reservoir drain hose with a clamp.
  - G. To the engine
  - H. Clamp the coolant reservoir drain hose to the lower side of the vehicle.  
Fasten the clutch cable and coolant reservoir drain hose with a clamp.
  - I. 80 to 100 mm (3.15 to 3.94 in)
  - J. Cut the clamp tip leaving 2 to 4 mm (0.08 to 0.16 in).
  - K. Route the rear brake light switch lead by the outer side of the vehicle than the O<sub>2</sub> sensor lead and push it into the mating surface section of the clutch cover.
  - L. Point the tip of the clamp (excessive part) to the lower front side of the vehicle.  
Fasten the right handlebar switch lead, radiator fan motor lead and ignition coil lead with a clamp.
  - M. Point the tip of the clamp (excessive part) to the upper side of the vehicle.  
Fasten the right handlebar switch lead, radiator fan motor lead and ignition coil lead with a clamp.
  - N. Pass the right handlebar switch lead and radiator fan motor lead between the frame and heat protector.
  - O. Clamp so that there is no slack at the left side of the vehicle.  
Fasten the air induction system solenoid lead, cylinder identification sensor lead, ignition coil lead and air induction system solenoid hose with a clamp.
  - P. The coupler for the air induction system solenoid lead and cylinder identification sensor lead should be connected above the ignition coil sub wire harness and it should not drop on the cylinder head cover behind the ignition coil.
  - Q. Clamp the clutch cable so that it is within this specified clamp (90°).
  - R. Route the lead to be positioned by the inner side of the vehicle than the tip of the clamp (excessive part.)
  - S. It should not enter the inner side of the vehicle than the radiator stay guide.

# CABLE ROUTING

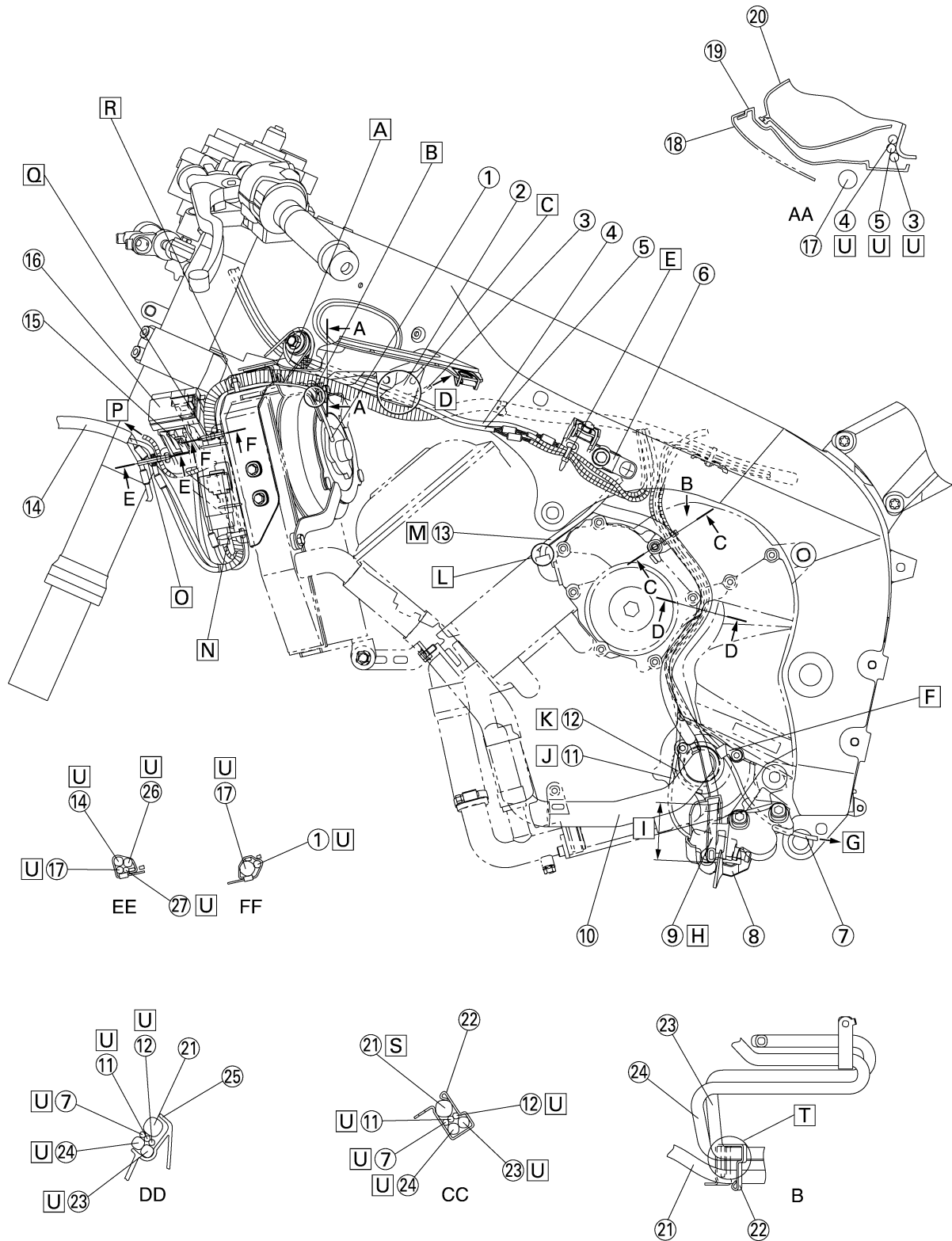

## CABLE ROUTING

1. Left radiator fan motor lead
  2. Heat protector
  3. Immobilizer lead
  4. Left handlebar switch lead
  5. Main switch lead
  6. Bracket
  7. EXUP servo motor lead
  8. Cover
  9. Fuel tank drain hose and fuel tank breather hose
  10. Water pipe
  11. Sidestand switch lead
  12. Oil level switch lead
  13. AC magneto lead
  14. Headlight lead
  15. Fuse box stay
  16. Fuse box
  17. Wire harness
  18. Cover
  19. Left air outlet grille
  20. Left intake air duct
  21. Water hose
  22. Stay
  23. Fuel tank drain hose
  24. Fuel tank breather hose
  25. Chain case cover
  26. Intake air temperature sensor lead
  27. Headlight lead and left turn signal light lead
- A. Clamp the leads so that they are positioned inner of the vehicle than the washer position after routing them between the frame and radiator stay. Align the clamp position with the taping sections of leads. Point the tip of the clamp (excessive part) to the lower front side of the vehicle. What the clamp fastens at this stage are the handlebar switch, main switch and immobilizer leads.
  - B. Check that the radiator fan motor lead is fixed with the guide of the radiator stay.
  - C. Pass the main switch lead, left handlebar switch lead and immobilizer lead between the frame and the heat protector.
  - D. To the inside of the frame
  - E. Point the tip of the clamp (excessive part) to the lower front side of the vehicle. Fasten the left handlebar switch lead and main switch lead with a clamp.
  - F. Fold back the clamp and secure it after passing the lead through the clamp.
  - G. To the EXUP servo motor
  - H. Pass the fuel tank drain hose and fuel tank breather hose through the hole of the cover from the outside of the water pipe after passing the water hose through first. Any direction of the hose cut edge can be accepted
  - I. 40 to 60mm (1.57 to 2.36 in)
  - J. Route the sidestand switch lead by the inside of the water hose and water pipe.
  - K. Route the oil level switch lead by the inside of the water hose and water pipe.
  - L. There should be no exposure of bared conductors due to the displacement of the tube.
  - M. Route by the outside of vehicle away from the water hose.
  - N. Point the tip of the clamp (excessive part) to the front inside of the vehicle. Fasten the wire harness and left radiator fan motor lead with a clamp.
  - O. Align the clamp position with the taping sections of headlight lead. Point the tip of the clamp (excessive part) to the rear inside of the stay. Fasten the headlight lead, intake air temperature sensor lead and wire harness with a clamp.
  - P. To the intake air temperature sensor
  - Q. Point the tip of the clamp (excessive part) to the front inside of the vehicle. Fasten the wire harness and left radiator fan motor lead with a clamp.
  - R. Align the clamp position with the taping sections of wire harness. Point the tip of the clamp (excessive part) to the inside of the vehicle. Fasten the wire harness and left radiator fan motor lead with a clamp.
  - S. Route the water hose so that it is placed at the outermost position finally after routing other leads and hoses in the guide.
  - T. Align the molded part of the fuel tank drain hose and fuel tank breather hose with the stay.
  - U. Can be routed in any order.

# CABLE ROUTING

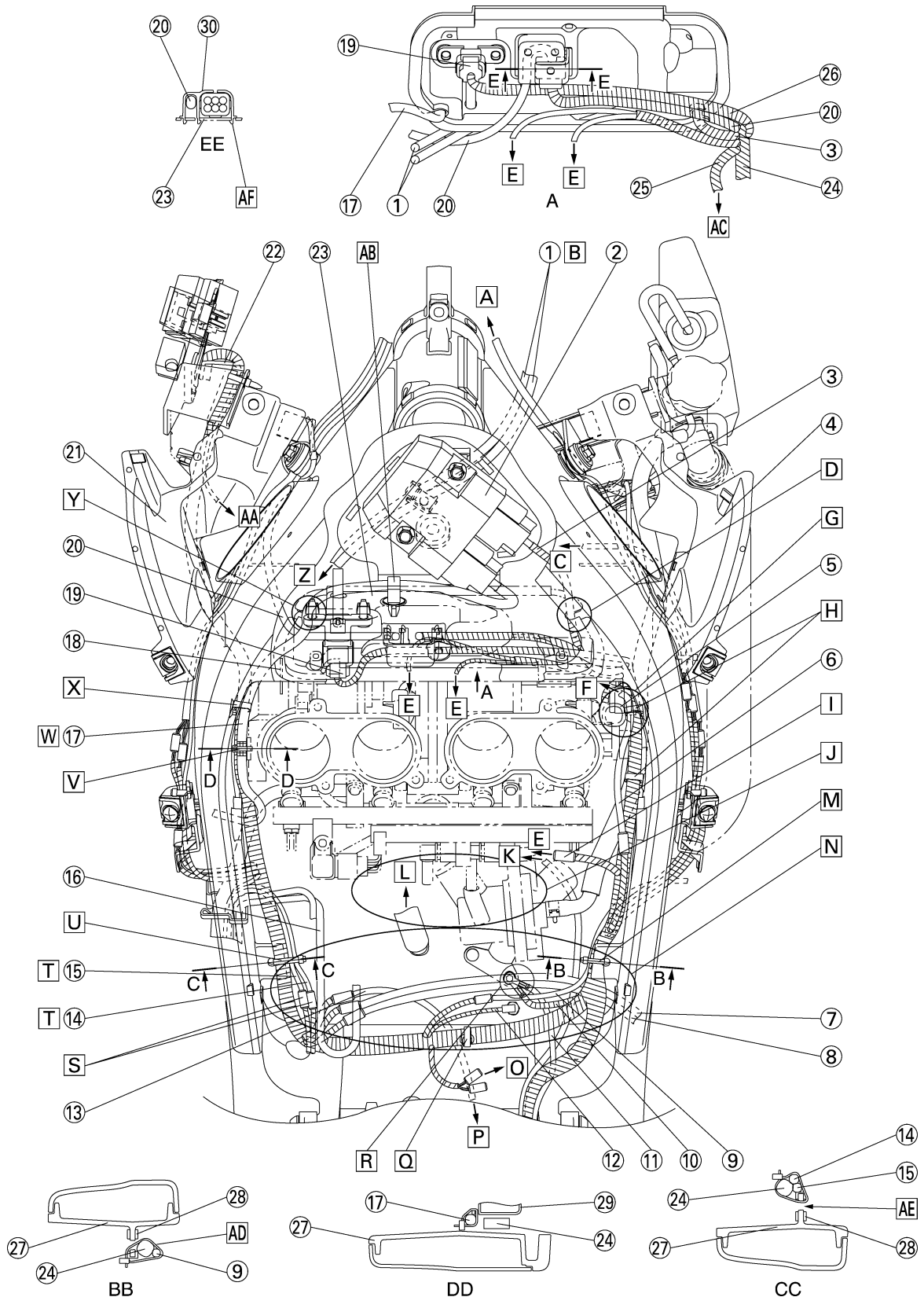

**CABLE ROUTING**

- 
1. Throttle cables
  2. Rectifier/regulator
  3. Rectifier/regulator lead
  4. Right air outlet grille
  5. Air induction system solenoid hose
  6. Intake funnel servo motor lead
  7. O<sub>2</sub> sensor lead
  8. Rear brake light switch lead
  9. Crankshaft position sensor lead
  10. Engine ground lead
  11. Battery negative lead
  12. Neutral switch lead
  13. Speed sensor lead
  14. Oil level switch lead
  15. Sidestand switch lead
  16. Fuel tank drain hose
  17. AC magneto lead
  18. Pulley cover rib
  19. Atmospheric pressure sensor
  20. Immobilizer lead
  21. Left air outlet grille
  22. Left radiator fan motor lead
  23. Cover 2
  24. Wire harness
  25. Throttle position sensor (for throttle valves) lead
  26. Atmospheric pressure sensor lead
  27. Frame
  28. Locating damper
  29. Throttle body
  30. Connector housing
- A. To the right handlebar switch lead.
  - B. Pass it so that there is no torsion through the clamp which inserted to the cover.
  - C. To the engine
  - D. Pass the rectifier/regulator lead through the notch hole of the cover.
  - E. To the throttle body
  - F. To the intake funnel servo motor
  - G. Intake funnel servo motor lead should be routed by the front and outer side than the air induction system solenoid hose.
  - H. Clamp the wire harness winding in and insert it to the frame hole.
  - I. After connecting the coupler, make sure to insert it between the delivery pipe and thermostat.
  - J. For routing the fuel hoses, refer to the fuel tank section.
  - K. To the starter motor
  - L. To the air filter case
  - M. Point the tip of the clamp (cut the tip of the clamp leaving 2 to 4 mm (0.08 to 0.16 in.)) to the inside of the vehicle.  
Fasten the wire harness and crankshaft position sensor lead with a clamp.
  - N. All hoses and leads should be routed over the vehicle's upper side above the heat protector.
  - O. To the fuel pump
  - P. To the speed sensor
  - Q. Clamp the wire harness winding in and insert it to the frame hole.
  - R. Install the leads so that the engine ground lead is positioned lower and the battery negative lead to be upper.  
Install the protrusion of each lead to be above the vehicle.
  - S. It should not be positioned on the harness.
  - T. Route it under the wire harness, speed sensor lead, O<sub>2</sub> sensor lead and rear brake light switch lead.
  - U. Point the tip of the clamp (cut the tip of the clamp leaving 2 to 4 mm (0.08 to 0.16 in.)) to the inside of the vehicle.  
Fasten the wire harness, oil level switch lead and sidestand switch lead with a clamp.
  - V. Align the clamp position with the taping sections  
Point the tip of the clamp (cut the tip of the clamp leaving 2 to 4 mm (0.08 to 0.16 in.)) to the upper side of the vehicle.  
Fasten the AC magneto lead with a clamp.
  - W. Route the AC magneto lead by the outside of the pulley cover rib.
  - X. Clamp the wire harness winding in and insert it to the frame hole.
  - Y. Pass the AC magneto lead through the notch hole of the cover 2.
  - Z. To the throttle cable lever
  - AA. To the radiator
  - AB. Clamp the AC magneto lead.
  - AC. To the throttle position sensor (for throttle valves)
  - AD. Route each lead lower than the frame plate.  
Leads should be routed in random order.  
Clamp can be inserted in any direction.
  - AE. Route each lead higher than the frame plate, pass it to the inside of the vehicle from the hole.  
Leads should be routed in random order.  
Clamp can be inserted in any direction.
  - AF. Fit the immobilizer lead coupler into the connector housing with its projection positioned as shown in the illustration, and then install the holder onto the cover 2.

# CABLE ROUTING

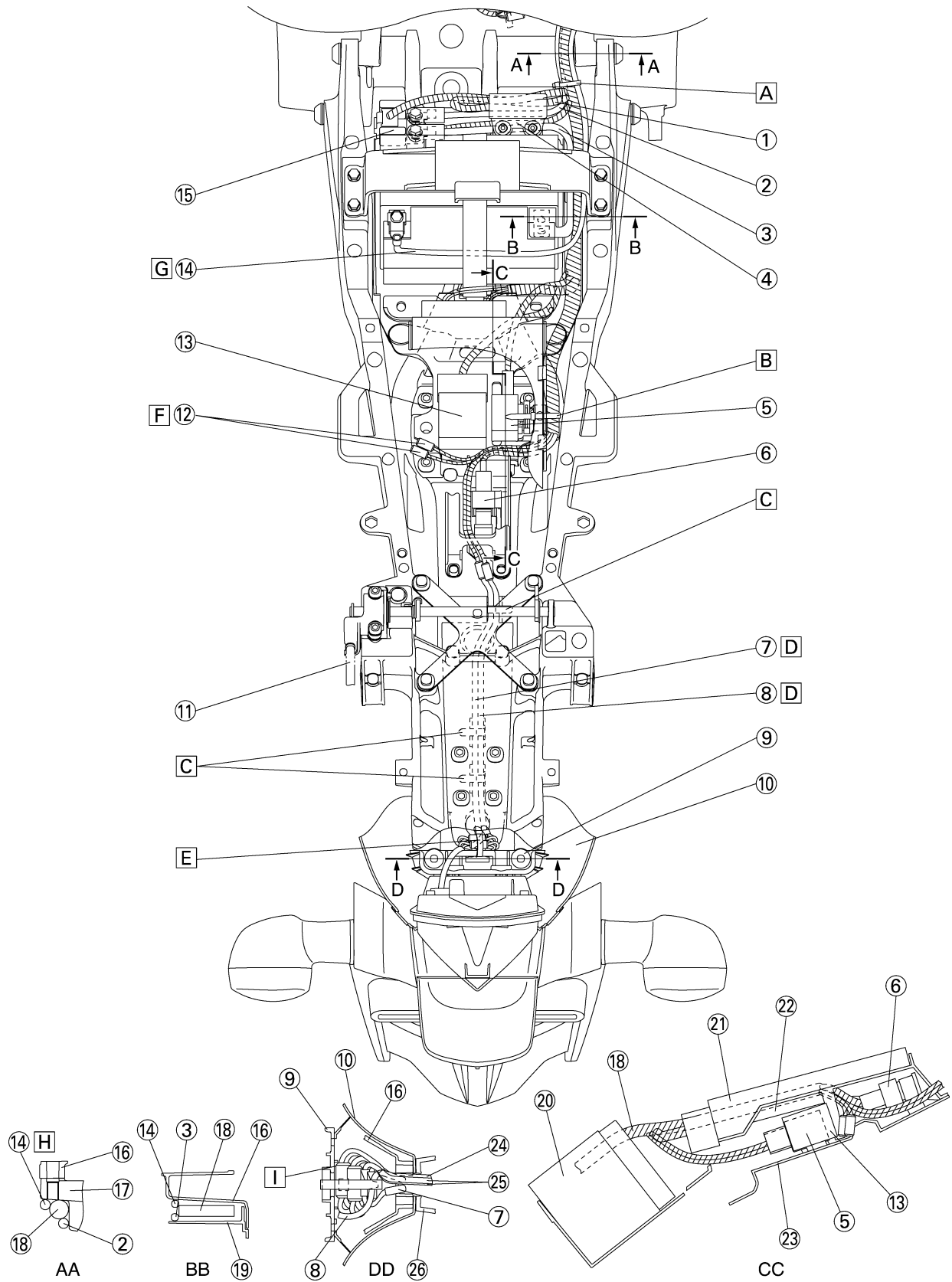

## CABLE ROUTING

---

1. Starter relay lead
  2. Starter motor lead
  3. Battery positive lead
  4. Lean angle sensor
  5. Turn signal/hazard relay
  6. Main fuse
  7. Turn signal light/license plate light lead
  8. Tail/brake light lead
  9. Tail/brake light bracket
  10. Lower tail cover
  11. Seat lock cable
  12. Anti safety alarm coupler
  13. Starting circuit cut-off relay
  14. Battery negative lead
  15. Starter relay
  16. Rear frame
  17. Rear arm bracket
  18. Wire harness
  19. Battery box 1
  20. Battery
  21. ECU (engine control unit)
  22. Cover
  23. Battery box 2
  24. License plate light lead
  25. Turn signal light lead
  26. Mud guard
- A. Point the tip of the clamp (excessive part) to the inner down side of the vehicle and clamp at the junction of the wire harness. Fasten the battery negative lead, wire harness and starter motor lead with a clamp.
  - B. Point the tip of the clamp (excessive part) to the inside of the vehicle. Fasten the wire harness with a clamp.
  - C. Hold down the clamp tips after passing each lead.
  - D. Insert the leads to the rear frame hole.
  - E. Insert the clamp from the vehicle front to the rear side and fasten each leads, coupler and onionhead to the tail/brake light bracket, and then point the tip of the clamp (excessive part) to the lower front side of the vehicle.
  - F. It should be set in the rear frame not to be caught in the sheet bottom or the covers.
  - G. Pass the battery negative lead through inside of the battery band.
  - H. Battery negative lead should not run on the rear arm bracket.
  - I. All leads should be positioned lower than the tail/brake light bracket.

# CABLE ROUTING

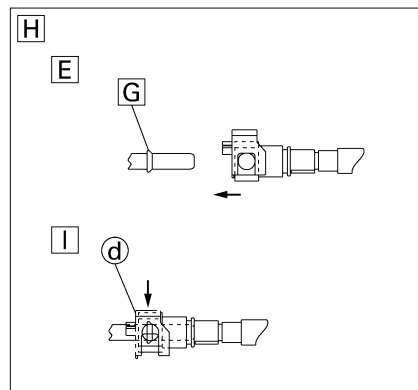
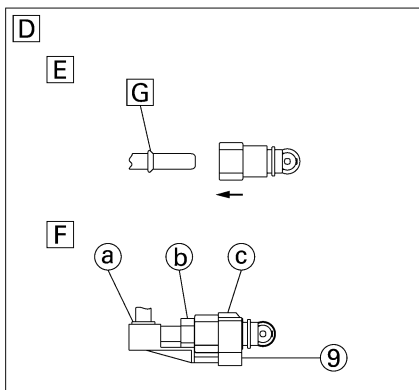
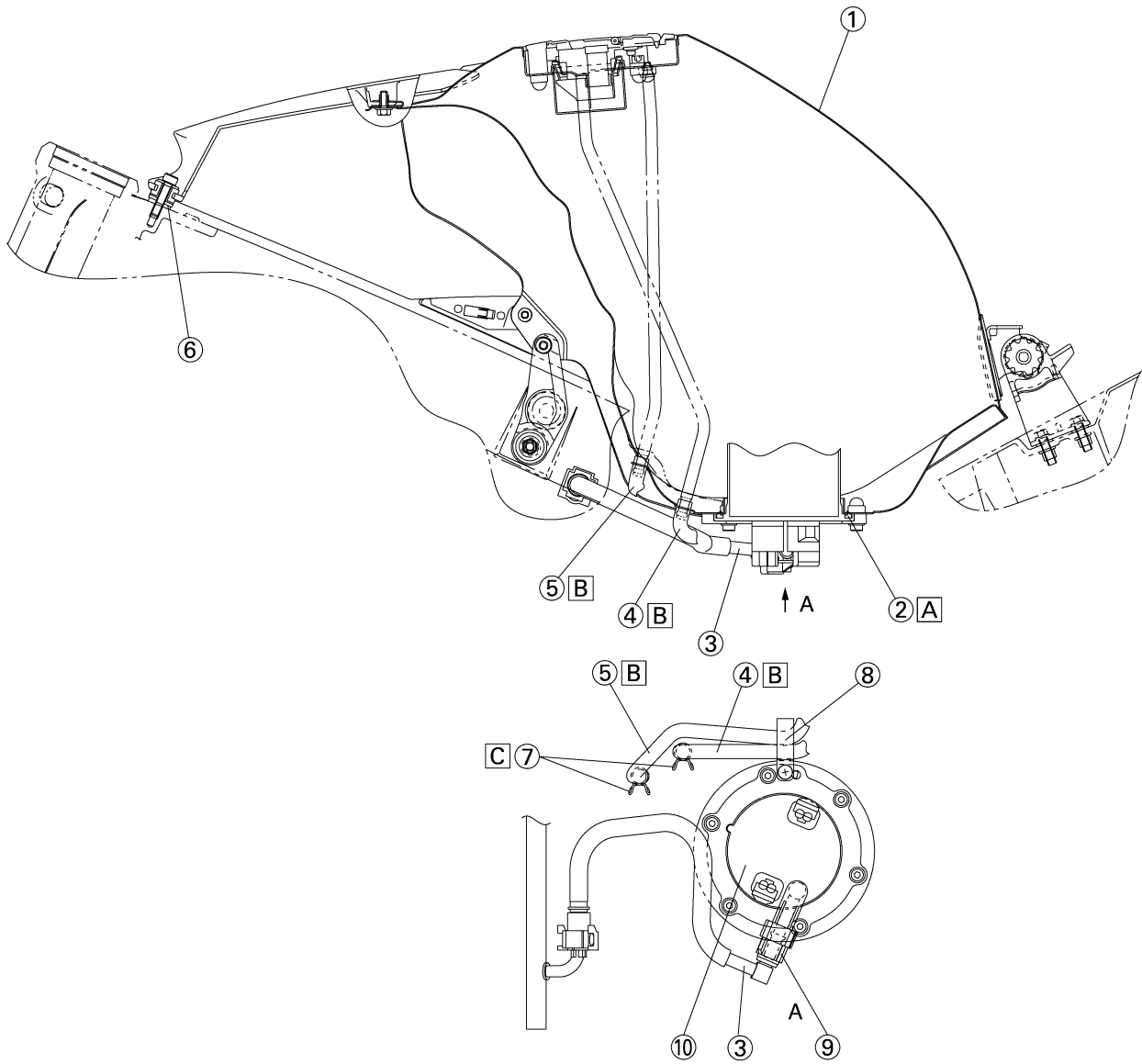

## CABLE ROUTING

---

1. Fuel tank
  2. O-ring
  3. Fuel hose
  4. Fuel tank drain hose
  5. Fuel tank breather hose
  6. Air filter stay
  7. Clip
  8. Fuel tank bracket
  9. Fuel hose clamp
  10. Fuel pump assembly
- A. Install the lip of O-ring facing upward.
  - B. Install the part pointing the white paint part of the hose to the left side of the vehicle.
  - C. Point the clip grip to the inside of the vehicle.
  - D. Fuel piping connector attachment directions. (fuel pump side)  
Always use hands to connect/disconnect the connector without using tool.
  - E. Insert the connector until the click sound is heard and check that the connector does not come off.  
Make sure that no foreign matter is caught in the sealing section.  
(It is prohibited to wear the cotton work gloves or equivalent coverings.)
  - F. After item "E" mentioned above is finished, check that the clamp is inserted from the down side "a", "b" and "c" sections are perfectly equipped.
  - G. This part works as a dropout stopper.
  - H. Fuel piping connector attachment directions. (engine side)  
Always use hands to connect/disconnect the connector without using tool.
  - I. After Step "H" as above is finished, check that the connector is completely attached by sliding the double lock (orange part) "d" on the connector as shown in the illustration and seeing if it touches firmly or not.

## **CABLE ROUTING**

---

---

## PERIODIC CHECKS AND ADJUSTMENTS

<b>PERIODIC MAINTENANCE</b> .....	3-1
INTRODUCTION .....	3-1
PERIODIC MAINTENANCE AND LUBRICATION CHART .....	3-1
<b>ENGINE</b> .....	3-4
ADJUSTING THE VALVE CLEARANCE .....	3-4
SYNCHRONIZING THE THROTTLE BODIES .....	3-7
ADJUSTING THE EXHAUST GAS VOLUME.....	3-8
ADJUSTING THE THROTTLE CABLE FREE PLAY .....	3-9
CHECKING THE SPARK PLUGS.....	3-10
MEASURING THE COMPRESSION PRESSURE .....	3-11
CHECKING THE ENGINE OIL LEVEL.....	3-12
CHANGING THE ENGINE OIL.....	3-12
MEASURING THE ENGINE OIL PRESSURE .....	3-13
ADJUSTING THE CLUTCH CABLE FREE PLAY .....	3-14
REPLACING THE AIR FILTER ELEMENT .....	3-15
CHECKING THE THROTTLE BODY JOINTS .....	3-16
CHECKING THE FUEL LINE .....	3-16
CHECKING THE CRANKCASE BREATHER HOSE .....	3-17
CHECKING THE EXHAUST SYSTEM.....	3-17
ADJUSTING THE EXUP CABLES .....	3-18
CHECKING THE EXUP SERVO MOTOR.....	3-19
CHECKING THE COOLANT LEVEL.....	3-19
CHECKING THE COOLING SYSTEM .....	3-20
CHANGING THE COOLANT .....	3-20
<b>CHASSIS</b> .....	3-23
ADJUSTING THE FRONT DISC BRAKE .....	3-23
ADJUSTING THE REAR DISC BRAKE .....	3-23
CHECKING THE BRAKE FLUID LEVEL.....	3-24
CHECKING THE FRONT BRAKE PADS.....	3-24
CHECKING THE REAR BRAKE PADS .....	3-25
CHECKING THE FRONT BRAKE HOSES.....	3-25
CHECKING THE REAR BRAKE HOSE .....	3-25
ADJUSTING THE REAR BRAKE LIGHT SWITCH .....	3-25
BLEEDING THE HYDRAULIC BRAKE SYSTEM.....	3-26
ADJUSTING THE SHIFT PEDAL .....	3-27
ADJUSTING THE DRIVE CHAIN SLACK .....	3-27
LUBRICATING THE DRIVE CHAIN.....	3-28
CHECKING AND ADJUSTING THE STEERING HEAD .....	3-28
CHECKING THE FRONT FORK .....	3-30
ADJUSTING THE FRONT FORK LEGS .....	3-30
ADJUSTING THE REAR SHOCK ABSORBER ASSEMBLY.....	3-32
CHECKING THE TIRES .....	3-33
CHECKING THE WHEELS .....	3-35
CHECKING AND LUBRICATING THE CABLES .....	3-35
LUBRICATING THE LEVERS.....	3-35
LUBRICATING THE PEDAL .....	3-36
LUBRICATING THE SIDESTAND.....	3-36

---

LUBRICATING THE REAR SUSPENSION .....	3-36
<b>ELECTRICAL SYSTEM</b> .....	3-37
CHECKING AND CHARGING THE BATTERY.....	3-37
CHECKING THE FUSES.....	3-37
REPLACING THE HEADLIGHT BULBS.....	3-37
ADJUSTING THE HEADLIGHT BEAMS .....	3-38



## PERIODIC MAINTENANCE

EAS20450

### PERIODIC MAINTENANCE

EAS20460

#### INTRODUCTION

This chapter includes all information necessary to perform recommended checks and adjustments. If followed, these preventive maintenance procedures will ensure more reliable vehicle operation, a longer service life and reduce the need for costly overhaul work. This information applies to vehicles already in service as well as to new vehicles that are being prepared for sale. All service technicians should be familiar with this entire chapter.

EAS4C81003

#### PERIODIC MAINTENANCE AND LUBRICATION CHART

**NOTE:** \_\_\_\_\_

- The annual checks must be performed every year, except if a kilometer-based maintenance is performed instead.
- From 50000 km, repeat the maintenance intervals starting from 10000 km.
- Items marked with an asterisk should be performed by a Yamaha dealer as they require special tools, data and technical skills.

NO.	ITEM	CHECK OR MAINTENANCE JOB	ODOMETER READING (× 1000 km)					Annual check
			1	10	20	30	40	
1	* Fuel line	• Check fuel hoses for cracks or damage.		√	√	√	√	√
2	* Spark plugs	• Check condition. • Clean and regap.		√		√		
		• Replace.			√		√	
3	* Valves	• Check valve clearance. • Adjust.	Every 40000 km					
4	Air filter element	• Replace.					√	
5	Clutch	• Check operation. • Adjust.	√	√	√	√	√	
6	* Front brake	• Check operation, fluid level and vehicle for fluid leakage.	√	√	√	√	√	√
		• Replace brake pads.	Whenever worn to the limit					
7	* Rear brake	• Check operation, fluid level and vehicle for fluid leakage.	√	√	√	√	√	√
		• Replace brake pads.	Whenever worn to the limit					
8	* Brake hoses	• Check for cracks or damage.		√	√	√	√	√
		• Replace.	Every 4 years					
9	* Wheels	• Check runout and for damage.		√	√	√	√	
10	* Tires	• Check tread depth and for damage. • Replace if necessary. • Check air pressure. • Correct if necessary.		√	√	√	√	√
11	* Wheel bearings	• Check bearing for looseness or damage.		√	√	√	√	

## PERIODIC MAINTENANCE

NO.	ITEM	CHECK OR MAINTENANCE JOB	ODOMETER READING (× 1000 km)					Annual check	
			1	10	20	30	40		
12	*	<b>Swingarm</b>	• Check operation and for excessive play.		√	√	√	√	
			• Lubricate with lithium-soap-based grease.	Every 50000 km					
13		<b>Drive chain</b>	• Check chain slack, alignment and condition. • Adjust and lubricate chain with a special O-ring chain lubricant thoroughly.	Every 800 km and after washing the motorcycle or riding in the rain					
14	*	<b>Steering bearings</b>	• Check bearing play and steering for roughness.	√	√	√	√	√	
			• Lubricate with lithium-soap-based grease.	Every 20000 km					
15	*	<b>Steering damper</b>	• Check operation and for oil leakage.		√	√	√	√	
16	*	<b>Chassis fasteners</b>	• Make sure that all nuts, bolts and screws are properly tightened.		√	√	√	√	√
17		<b>Shift pedal rod pivots</b>	• Lubricate with lithium-soap-based grease.		√	√	√	√	√
18		<b>Sidestand</b>	• Check operation. • Lubricate.		√	√	√	√	√
19	*	<b>Sidestand switch</b>	• Check operation.	√	√	√	√	√	√
20	*	<b>Front fork</b>	• Check operation and for oil leakage.		√	√	√	√	
21	*	<b>Shock absorber assembly</b>	• Check operation and shock absorber for oil leakage.		√	√	√	√	
22	*	<b>Rear suspension relay arm and connecting arm pivoting points</b>	• Check operation.		√	√	√	√	
23	*	<b>Fuel injection system</b>	• Adjust synchronization.		√	√	√	√	√
24		<b>Engine oil</b>	• Change. • Check oil level and vehicle for oil leakage.	√	√	√	√	√	√
25		<b>Engine oil filter cartridge</b>	• Replace.	√		√		√	
26	*	<b>Cooling system</b>	• Check coolant level and vehicle for coolant leakage.		√	√	√	√	√
			• Change.	Every 3 years					
27	*	<b>Front and rear brake switches</b>	• Check operation.	√	√	√	√	√	√
28		<b>Moving parts and cables</b>	• Lubricate.		√	√	√	√	√

## PERIODIC MAINTENANCE

NO.	ITEM	CHECK OR MAINTENANCE JOB	ODOMETER READING (× 1000 km)					Annual check
			1	10	20	30	40	
29	*	<b>Throttle grip housing and cable</b>		√	√	√	√	√
30	*	<b>Air induction system</b>		√	√	√	√	√
31	*	<b>Muffler and exhaust pipe</b>	√	√	√	√	√	
32	*	<b>EXUP system</b>	√		√		√	
33	*	<b>Lights, signals and switches</b>	√	√	√	√	√	√

**NOTE:**

- Air filter
  - This model’s air filter is equipped with a disposable oil-coated paper element, which must not be cleaned with compressed air to avoid damaging it.
  - The air filter element needs to be replaced more frequently when riding in unusually wet or dusty areas.
- Hydraulic brake service
  - Regularly check and, if necessary, correct the brake fluid level.
  - Every two years replace the internal components of the brake master cylinders and calipers, and change the brake fluid.
  - Replace the brake hoses every four years and if cracked or damaged.

EAS20470

**ENGINE**

EAS20490

**ADJUSTING THE VALVE CLEARANCE**

The following procedure applies to all of the valves.

**NOTE:**

- Valve clearance adjustment should be made on a cold engine, at room temperature.
- When the valve clearance is to be measured or adjusted, the piston must be at top dead center (TDC) on the compression stroke.

## 1. Remove:

- Rider seat  
Refer to "GENERAL CHASSIS" on page 4-1.
- Fuel tank  
Refer to "FUEL TANK" on page 7-1.
- Air filter case  
Refer to "GENERAL CHASSIS" on page 4-1.
- Lower cowlings
- Side cowlings  
Refer to "GENERAL CHASSIS" on page 4-1.
- Throttle body assembly  
Refer to "THROTTLE BODIES" on page 7-4.
- Air cut-off valve  
Refer to "AIR INDUCTION SYSTEM" on page 7-9.
- Radiator
- Radiator fan motor  
Refer to "RADIATOR" on page 6-1.

## 2. Remove:

- Ignition coils
- Spark plugs
- Cylinder head cover
- Cylinder head cover gasket  
Refer to "CAMSHAFTS" on page 5-9.

## 3. Remove:

- Pickup rotor cover "1"

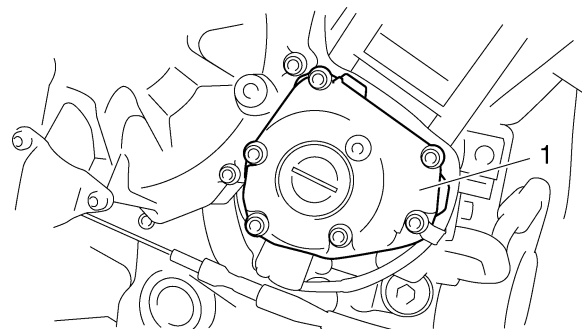

## 4. Measure:

- Valve clearance  
Out of specification → Adjust.

Valve clearance (cold)
<b>Intake</b> 0.11–0.20 mm (0.0043–0.0079 in)
<b>Exhaust</b> 0.26–0.30 mm (0.0102–0.0118 in)

- a. Turn the crankshaft counterclockwise.
- b. When piston #1 is at TDC on the compression stroke, align the TDC mark "a" on the generator rotor with the mark "b" on the crankcase.

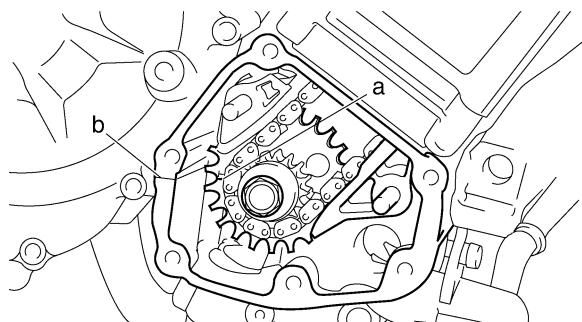
**NOTE:**

TDC on the compression stroke can be found when the camshaft lobes are turned away from each other.

- c. Measure the valve clearance with a thickness gauge "2".

**NOTE:**

- If the valve clearance is incorrect, record the measured reading.
- Measure the valve clearance in the following sequence.



# ENGINE

**NOTE:**

- The thickness “a” of each valve pad is marked in hundredths of millimeters on the side that touches the valve lifter.
- Since valve pads of various sizes are originally installed, the valve pad number must be rounded in order to reach the closest equivalent to the original.

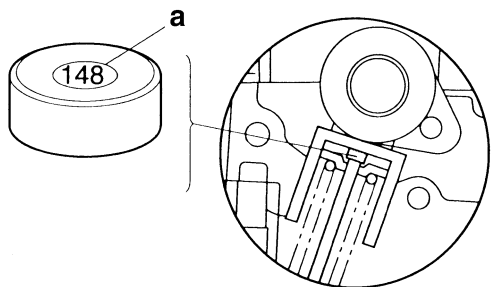

c. Round off the original valve pad number according to the following table.

Last digit	Rounded value
0 or 2	0
5	5
8	10

**EXAMPLE:**

Original valve pad number = 148 (thickness = 1.48 mm (0.058 in))  
 Rounded value = 150

d. Locate the rounded number of the original valve pad and the measured valve clearance in the valve pad selection table. The point where the column and row intersect is the new valve pad number.

**NOTE:**

The new valve pad number is only an approximation. The valve clearance must be measured again and the above steps should be repeated if the measurement is still incorrect.

e. Install the new valve pad “1” and the valve lifter “2”.

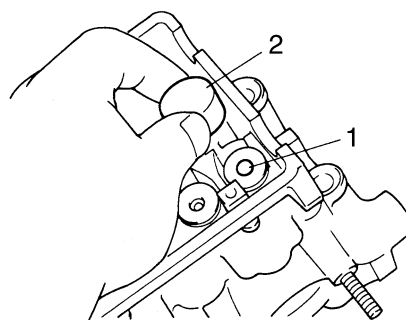

**NOTE:**

- Lubricate the valve pad with molybdenum disulfide grease.
- Lubricate the valve lifter with molybdenum disulfide oil.
- The valve lifter must turn smoothly when rotated by hand.
- Install the valve lifter and the valve pad in the correct place.

f. Install the exhaust and intake camshafts, timing chain and camshaft caps.

	<b>Camshaft cap bolt</b> <b>10 Nm (1.0 m·kg, 7.2 ft·lb)</b>
---	--

**NOTE:**

- Refer to "CAMSHAFTS" on page 5-9.
- Lubricate the camshaft bearings, camshaft lobes and camshaft journals.
- First, install the exhaust camshaft.
- Align the camshaft marks with the camshaft cap marks.
- Turn the crankshaft counterclockwise several full turns to seat the parts.

- g. Measure the valve clearance again.
- h. If the valve clearance is still out of specification, repeat all of the valve clearance adjustment steps until the specified clearance is obtained.



7. Install:

- All removed parts

**NOTE:**

For installation, reverse the removal procedure. Note the following points.

# ENGINE

EAS20570

## SYNCHRONIZING THE THROTTLE BODIES

**NOTE:** \_\_\_\_\_

Prior to synchronizing the throttle bodies, the valve clearance should be properly adjusted and the ignition timing should be checked.

1. Stand the vehicle on a level surface.

**NOTE:** \_\_\_\_\_

Place the vehicle on a suitable stand.

2. Remove:
  - Rider seat  
Refer to "GENERAL CHASSIS" on page 4-1.
  - Fuel tank side covers
  - Fuel tank  
Refer to "FUEL TANK" on page 7-1.
  - Air filter case  
Refer to "GENERAL CHASSIS" on page 4-1.
3. Remove:
  - Synchronizing hoses "1"

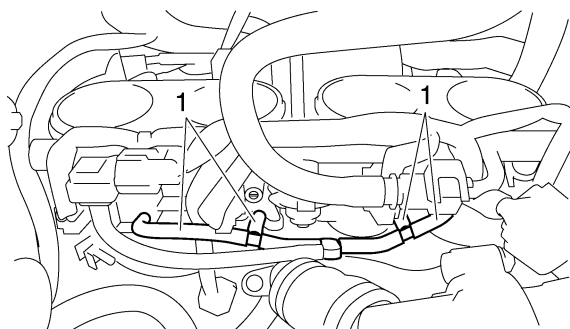

4. Install:
  - Vacuum gauge "1"  
(onto the synchronizing hose)

	<p><b>Vacuum gauge</b> 90890-03094</p> <p><b>Carburetor synchronizer</b> YU-44456</p>
---	---

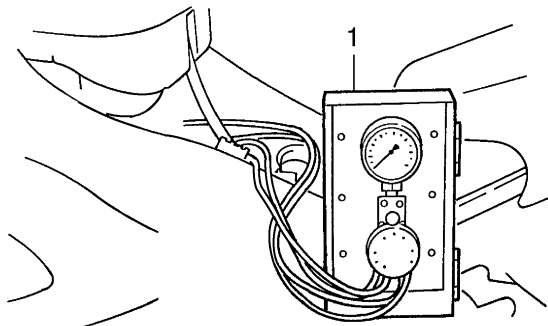

5. Install:
  - Fuel tank  
Refer to "FUEL TANK" on page 7-1.
6. Start the engine and let it warm up for several minutes.
7. Check:
  - Engine idling speed

	<p><b>Engine idling speed</b> 1150–1250 r/min</p>
---	---

8. Adjust:
  - Throttle body synchronization



**Basic procedure**

- a. Start the engine, warm it up for several minutes, and then let it run at the specified engine idling speed.

	<p><b>Engine idling speed</b> 1150–1250 r/min</p>
---	---

- b. Turn the bypass air screw "1" with a white paint mark out a little, and then turn it in fully.

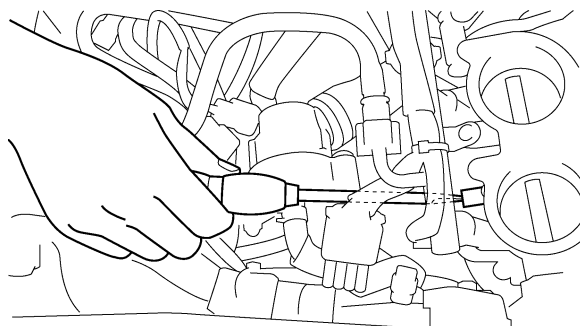
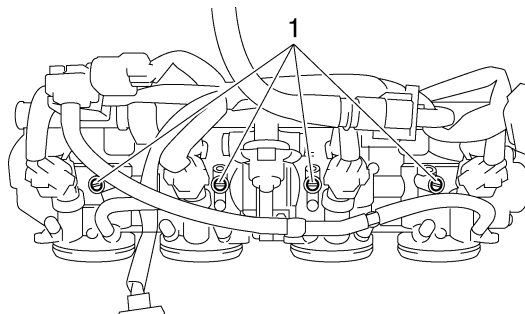

- c. Using the throttle body that has the bypass air screw with a white paint mark as the standard, turn the bypass air screws without white paint marks in or out to the adjust the other throttle bodies.

# ENGINE

**NOTE:**

- If more than one throttle body has a bypass air screw with a white paint mark, use the one with the lowest vacuum pressure as the standard.
- After each step, rev the engine two or three times, each time for less than a second, and check the synchronization again.
- If an air screw was removed, turn the screw 3/4 turn in and be sure to synchronize the throttle body.



**Intake vacuum**  
22.0 kPa (6.5 inHg) (165 mmHg)

**NOTE:**

- The difference in vacuum pressure between two throttle bodies should not exceed 1.33 kPa (10 mmHg).
- If you are unable to adjust the throttle body synchronization using this procedure, use the following procedure instead.



**Alternate procedure**

**NOTE:**

Use this alternate procedure if you are unable to adjust the throttle body synchronization using the basic procedure.

- Start the engine, warm it up for several minutes, and then let it run at the specified engine idling speed.



**Engine idling speed**  
1150–1250 r/min

- Turn all of the bypass air screws in fully.
- Using the throttle body with the lowest vacuum pressure as the standard, turn out the bypass air screws of the other throttle bodies to adjust them.

**NOTE:**

- Do not turn out the bypass air screw of the throttle body with the lowest vacuum pressure.
- After each step, rev the engine two or three times, each time for less than a second, and check the synchronization again.

- If an air screw was removed, turn the screw 3/4 turn in and be sure to synchronize the throttle body.



**Intake vacuum**  
22.0 kPa (6.5 inHg) (165 mmHg)

**NOTE:**

The difference in vacuum pressure between two throttle bodies should not exceed 1.33 kPa (10 mmHg).



- Stop the engine and remove the measuring equipment.
- Adjust:
  - Throttle cable free play  
Refer to "ADJUSTING THE THROTTLE CABLE FREE PLAY" on page 3-9.



**Throttle cable free play**  
3.0–5.0 mm (0.12–0.20 in)

- Install:
  - Fuel tank  
Refer to "FUEL TANK" on page 7-1.
  - Fuel tank side cover  
Refer to "GENERAL CHASSIS" on page 4-1.

EAS20600

**ADJUSTING THE EXHAUST GAS VOLUME**

**NOTE:**

Be sure to set the CO density level to standard, and then adjust the exhaust gas volume.

- Turn the main switch to "OFF" and set the engine stop switch to "ON".
- Simultaneously press and hold the "SELECT" and "RESET" buttons, turn the main switch to "ON", and continue to press the buttons for 8 seconds or more.

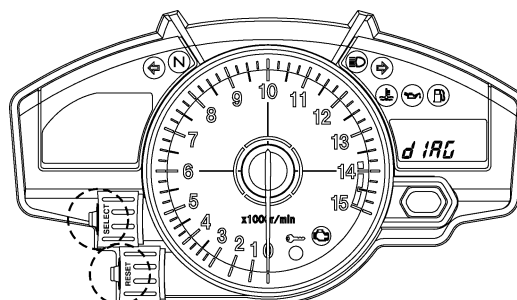

## ENGINE

**NOTE:**

“diag” appears on the odometer, tripmeter and fuel reserve trip LCD.

3. Press the “SELECT” button to select the CO adjustment mode “CO” or the diagnostic mode “diag”.

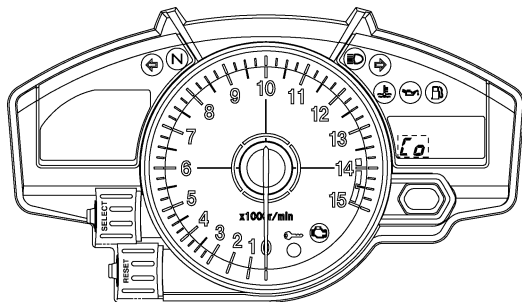

4. After selecting “CO”, simultaneously press the “SELECT” and “RESET” buttons for 2 seconds or more to execute the selection.
5. Press the “SELECT” and “RESET” buttons to select a cylinder.

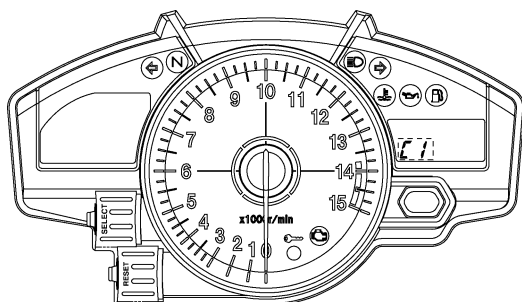

**NOTE:**

The selected cylinder number appears on the odometer, tripmeter and fuel reserve trip LCD.

- To decrease the selected cylinder number, press the “RESET” button.
- To increase the selected cylinder number, press the “SELECT” button.

6. After selecting the cylinder, simultaneously press the “SELECT” and “RESET” buttons for 2 seconds or more to execute the selection.

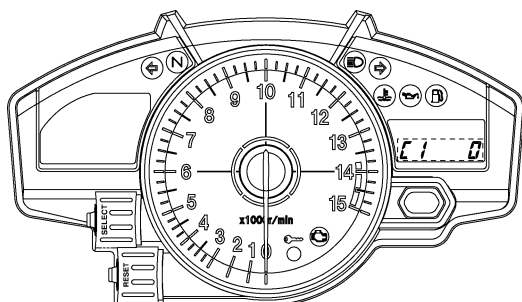

7. Change the CO adjustment volume by pressing the “SELECT” and “RESET” buttons.

**NOTE:**

The CO adjustment volume appears on the tripmeter LCD.

- To decrease the CO adjustment volume, press the “RESET” button.
- To increase the CO adjustment volume, press the “SELECT” button.

8. Release the switch to execute the selection.
9. Simultaneously press the “SELECT” and “RESET” buttons to return to the cylinder selection (step 5).
10. Turn the main switch to “OFF” to cancel the mode.

EAS20630

### ADJUSTING THE THROTTLE CABLE FREE PLAY

**NOTE:**

Prior to adjusting the throttle cable free play, the carburetor synchronization should be adjusted properly.

1. Check:
  - Throttle cable free play “a”  
Out of specification → Adjust.

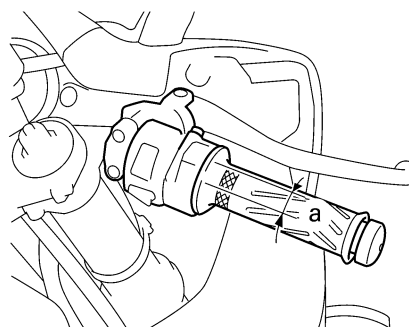

**Throttle cable free play**  
3.0–5.0 mm (0.12–0.20 in)

2. Adjust:
  - Throttle cable free play

#### Handlebar side

- a. Loosen the locknut “1”.
- b. Turn the adjusting nut “2” in direction “a” or “b” until the specified throttle cable free play is obtained.

# ENGINE

**Direction "a"**  
Throttle cable free play is increased.  
**Direction "b"**  
Throttle cable free play is decreased.

c. Tighten the locknut "1".

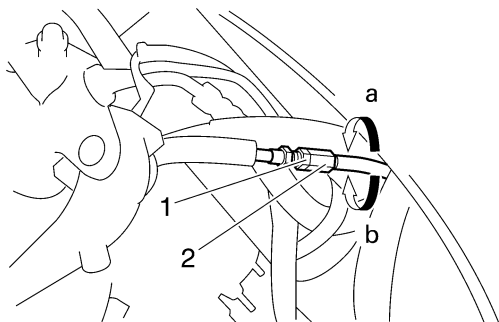

EWA4C81006

**WARNING**

After adjusting the throttle cable free play, start the engine and turn the handlebars to the right and to the left to ensure that this does not cause the engine idling speed to change.



EAS20680

### CHECKING THE SPARK PLUGS

The following procedure applies to all of the spark plugs.

1. Remove:
  - Side cowlings
  - Lower cowlings
 Refer to "GENERAL CHASSIS" on page 4-1.
2. Remove:
  - Radiator upper bolts
  - Radiator lower bolt
 Refer to "RADIATOR" on page 6-1.
3. Disconnect:
  - Ignition coils
4. Remove:
  - Spark plugs

ECA13320

**CAUTION:**

Before removing the spark plugs, blow away any dirt accumulated in the spark plug wells with compressed air to prevent it from falling into the cylinders.

5. Check:
  - Spark plug type
 Incorrect → Change.



**Manufacturer/model**  
**NGK/CR9EK**

6. Check:
  - Electrode "1"  
Damage/wear → Replace the spark plug.
  - Insulator "2"  
Abnormal color → Replace the spark plug.  
Normal color is medium-to-light tan.
7. Clean:
  - Spark plugs  
(with a spark plug cleaner or wire brush)
8. Measure:
  - Spark plug gap "a"  
(with a wire thickness gauge)  
Out of specification → Regap.



**Spark plug gap**  
**0.6–0.7 mm (0.024–0.028 in)**

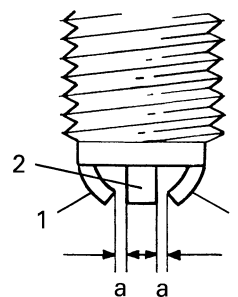

9. Install:
  - Spark plugs
  - Ignition coils



**Spark plug**  
**13 Nm (1.3 m·kg, 9.4 ft·lb)**

**NOTE:**

Before installing the spark plug, clean the spark plug and gasket surface.

10. Install:
  - Radiator upper bolts
  - Radiator lower bolt
 Refer to "RADIATOR" on page 6-1.
11. Install:
  - Side cowlings
  - Lower cowlings
 Refer to "GENERAL CHASSIS" on page 4-1.

# ENGINE

EAS20710

## MEASURING THE COMPRESSION PRESSURE

The following procedure applies to all of the cylinders.

**NOTE:**

Insufficient compression pressure will result in a loss of performance.

1. Measure:
  - Valve clearance  
Out of specification → Adjust.  
Refer to "ADJUSTING THE VALVE CLEARANCE" on page 3-4.
2. Start the engine, warm it up for several minutes, and then turn it off.
3. Disconnect:
  - Ignition coils
4. Remove:
  - Ignition coils
  - Spark plugs

ECA13340

**CAUTION:**

**Before removing the spark plugs, use compressed air to blow away any dirt accumulated in the spark plug wells to prevent it from falling into the cylinders.**

5. Install:
  - Compression gauge "1"
  - Extension

	<p><b>Compression gauge</b> <b>90890-03081</b></p> <p><b>Engine compression tester</b> <b>YU-33223</b></p> <p><b>Extension</b> <b>90890-04136</b></p>
---	---

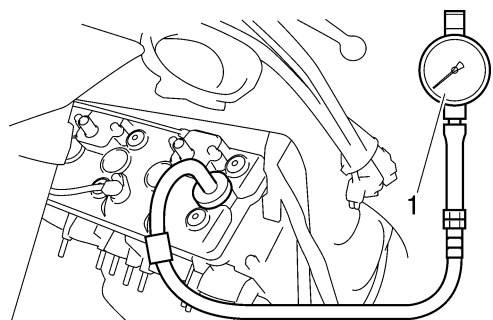

6. Measure:
  - Compression pressure  
Out of specification → Refer to steps (c) and (d).



**Standard compression pressure (at sea level)**

**1480 kPa/350 r/min (210.5 psi/350 r/min) (14.8 kgf/cm<sup>2</sup>/350 r/min)**

**Minimum–Maximum**

**1290–1660 kPa (183.5–236.1 psi) (12.9–16.6 kgf/cm<sup>2</sup>)**



- a. Set the main switch to "ON".
- b. With the throttle wide open, crank the engine until the reading on the compression gauge stabilizes.

EWA4C81007

**WARNING**

**To prevent sparking, ground all speak plug leads before cranking the engine.**

**NOTE:**

The difference in compression pressure between cylinders should not exceed 100 kPa (1 kg/cm<sup>2</sup>, 14 psi).

- c. If the compression pressure is above the maximum specification, check the cylinder head, valve surfaces and piston crown for carbon deposits.  
Carbon deposits → Eliminate.
- d. If the compression pressure is below the minimum specification, pour a teaspoonful of engine oil into the spark plug bore and measure again.  
Refer to the following table.

Compression pressure (with oil applied into the cylinder)	
Reading	Diagnosis
Higher than without oil	Piston ring(s) wear or damage → Repair.
Same as without oil	Piston, valves, cylinder head gasket or piston possibly defective → Repair.



7. Install:
  - Spark plugs
  - Ignition coils



**Spark plug**  
**13 Nm (1.3 m·kg, 9.4 ft·lb)**

# ENGINE

8. Connect:
- Ignition coils

EAS20730

### CHECKING THE ENGINE OIL LEVEL

1. Stand the vehicle on a level surface.

**NOTE:** \_\_\_\_\_

- Place the vehicle on a suitable stand.
- Make sure the vehicle is upright.

2. Start the engine, warm it up for several minutes, and then turn it off.

3. Check:

- Engine oil level

The engine oil level should be between the minimum level mark "a" and maximum level mark "b".

Below the minimum level mark → Add the recommended engine oil to the proper level.

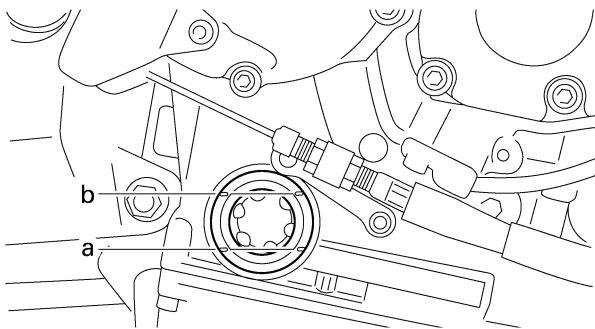



**Type**  
**SAE10W30, SAE10W40, SAE15W40, SAE20W40 or SAE20W50**  
**Recommended engine oil grade**  
**API service, SG type or higher, JASO standard MA**

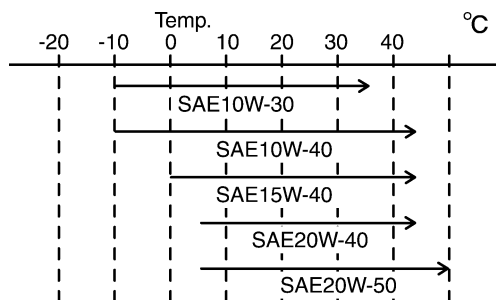

ECA13360

**CAUTION:** \_\_\_\_\_

- Engine oil also lubricates the clutch and the wrong oil types or additives could

cause clutch slippage. Therefore, do not add any chemical additives or use engine oils with a grade of CD "a" or higher and do not use oils labeled "ENERGY CONSERVING II" "b".

- Do not allow foreign materials to enter the crankcase.

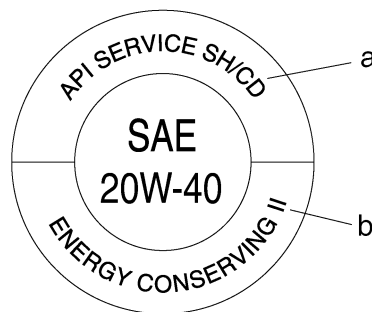

4. Start the engine, warm it up for several minutes, and then turn it off.

5. Check the engine oil level again.

**NOTE:** \_\_\_\_\_

Before checking the engine oil level, wait a few minutes until the oil has settled.

EAS20790

### CHANGING THE ENGINE OIL

1. Start the engine, warm it up for several minutes, and then turn it off.
2. Place a container under the engine oil drain bolt.
3. Remove:
  - Lower cowlings
 Refer to "GENERAL CHASSIS" on page 4-1.
4. Remove:
  - Engine oil filler cap "1"
  - Engine oil drain bolt "2" (along with the gasket)

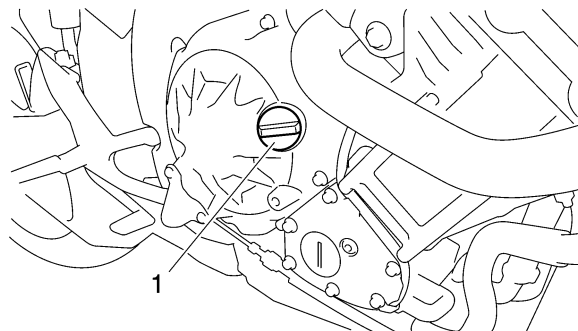

# ENGINE

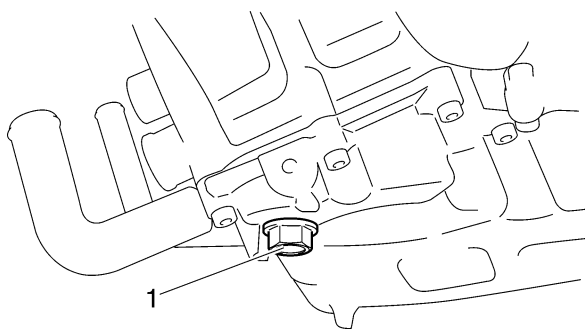

5. Drain:
  - Engine oil (completely from the crankcase)
6. If the oil filter cartridge is also to be replaced, perform the following procedure.

a. Remove the oil filter cartridge "1" with an oil filter wrench "2".

	<p><b>Oil filter wrench</b>  <b>90890-01426</b>  <b>YU-38411</b></p>
---	--

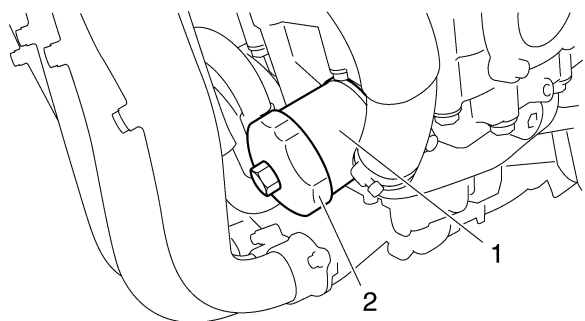

- b. Lubricate the O-ring "3" of the new oil filter cartridge with a thin coat of engine oil.

ECA13390

**CAUTION:**

**Make sure the O-ring "3" is positioned correctly in the groove of the oil filter cartridge.**

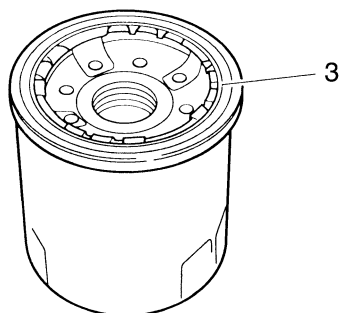

11730302

- c. Tighten the new oil filter cartridge to specification with an oil filter wrench.

	<p><b>Oil filter cartridge</b>  <b>17 Nm (1.7 m·kg, 12 ft·lb)</b></p>
---	---



7. Check:
  - Engine oil drain bolt gasket **New**
8. Install:
  - Engine oil drain bolt (along with the gasket)

	<p><b>Engine oil drain bolt</b>  <b>43 Nm (4.3 m·kg, 31 ft·lb)</b></p>
---	--

9. Fill:
  - Crankcase (with the specified amount of the recommended engine oil)

	<p><b>Engine oil quantity</b>  <b>Total amount</b>  <b>3.83 L (4.05 US qt) (3.37 Imp.qt)</b>  <b>Without oil filter cartridge replacement</b>  <b>2.90 L (3.07 US qt) (2.55 Imp.qt)</b>  <b>With oil filter cartridge replacement</b>  <b>3.10 L (3.28 US qt) (2.73 Imp.qt)</b></p>
---	---

10. Install:
  - Engine oil filler cap
  - Lower cowlings Refer to "GENERAL CHASSIS" on page 4-1.
11. Start the engine, warm it up for several minutes, and then turn it off.
12. Check:
  - Engine (for engine oil leaks)
13. Check:
  - Engine oil level Refer to "CHECKING THE ENGINE OIL LEVEL" on page 3-12.

EAS20820

**MEASURING THE ENGINE OIL PRESSURE**

1. Check:
  - Engine oil level Below the minimum level mark "a" → Add the recommended engine oil to the proper level.

# ENGINE

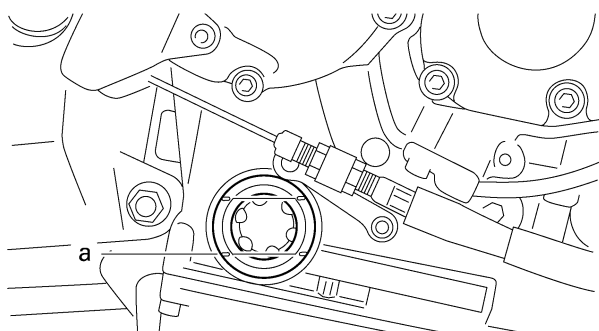

2. Start the engine, warm it up for several minutes, and then turn it off.

ECA13410

**CAUTION:**

When the engine is cold, the engine oil will have a higher viscosity, causing the engine oil pressure to increase. Therefore, be sure to measure the engine oil pressure after warming up the engine.

3. Remove:

- Main gallery bolt “1”

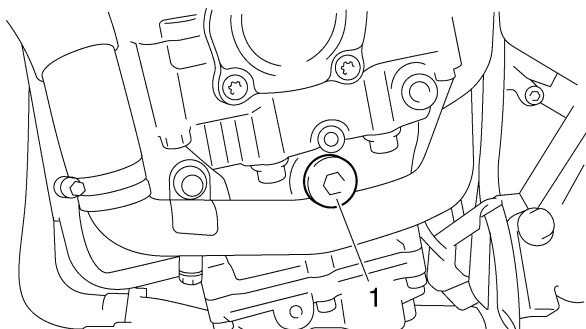

EWA12980

**WARNING**

The engine, muffler and engine oil are extremely hot.

4. Install:

- Oil pressure gauge “1”
- Adapter “2”

	<b>Oil pressure gauge set</b>
	<b>90890-03153</b>
	<b>YU-03153</b>
	<b>Oil pressure adapter H</b>
	<b>90890-03139</b>

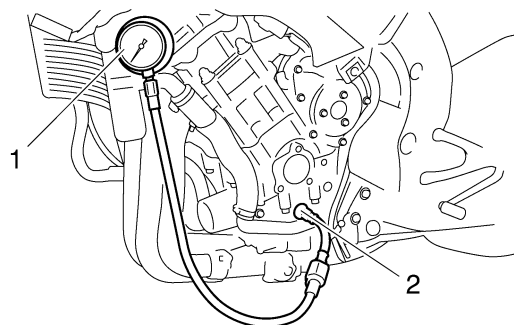

5. Measure:

- Engine oil pressure (at the following conditions)  
Out of specification → Adjust.

	<b>Engine oil pressure</b>
	<b>230 kPa (2.3 psi) (32.71 kgf/cm<sup>2</sup>)</b>
	<b>Engine speed</b>
	<b>Approx 5000r/min</b>
	<b>Oil temperature</b>
	<b>80.0–90.0 °C (176.00–194.00 °F)</b>

Engine oil pressure	Possible causes
Below specification	<ul style="list-style-type: none"> <li>• Faulty oil pump</li> <li>• Clogged oil filter</li> <li>• Leaking oil passage</li> <li>• Broken or damaged oil seal</li> </ul>
Above specification	<ul style="list-style-type: none"> <li>• Leaking oil passage</li> <li>• Faulty oil filter</li> <li>• Oil viscosity too high</li> </ul>

6. Install:

- Main gallery bolt

	<b>Main gallery bolt</b>
	<b>8 Nm (0.8 m·kg, 5.8 ft·lb)</b>

ECA4C81014

**CAUTION:**

Be careful to tighten too much.

EAS20870

## ADJUSTING THE CLUTCH CABLE FREE PLAY

1. Check:

- Clutch cable free play “a”  
Out of specification → Adjust.

# ENGINE



**Clutch lever free play**  
10.0–15.0 mm (0.39–0.59 in)

2. Adjust:
  - Clutch cable free play

### Handlebar side

- a. Turn the adjusting bolt “1” in direction “b” or “c” until the specified clutch cable free play is obtained.

**Direction “b”**  
Clutch cable free play is increased.  
**Direction “c”**  
Clutch cable free play is decreased.

- b. Tighten the locknut “1”.

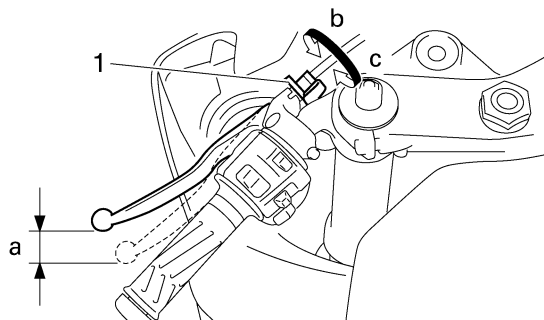

### NOTE:

If the specified clutch cable free play cannot be obtained on the handlebar side of the cable, use the adjusting nut on the engine side.

### Engine side

- a. Loosen the locknuts “1”.
- b. Turn the adjusting bolt “2” in direction “a” or “b” until the specified clutch cable free play is obtained.

**Direction “a”**  
Clutch cable free play is increased.  
**Direction “b”**  
Clutch cable free play is decreased.



**Locknut**  
7 Nm (0.7 m·kg, 5.1 ft·lb)

- c. Tighten the locknuts “1”.

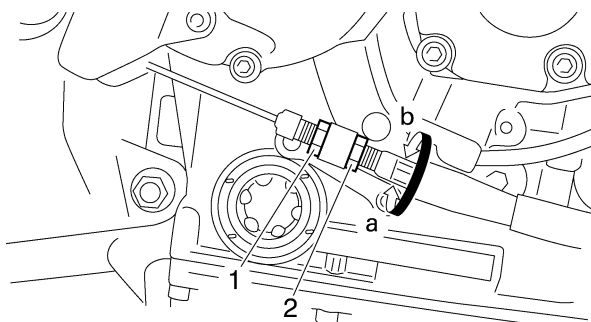

EAS20960

### REPLACING THE AIR FILTER ELEMENT

1. Remove:
  - Rider seat  
Refer to "GENERAL CHASSIS" on page 4-1.
  - Fuel tank side covers
  - Fuel tank  
Refer to "FUEL TANK" on page 7-1.
2. Remove:
  - Air filter case cover “1”  
Refer to "GENERAL CHASSIS" on page 4-1.

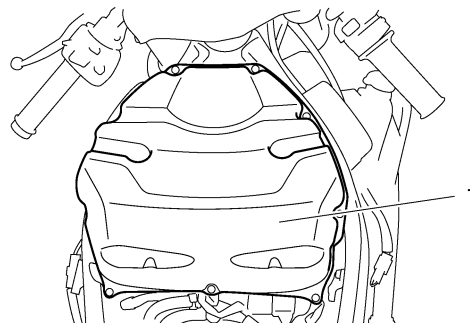

3. Check:
  - Air filter element “1”  
Damage → Replace.

### NOTE:

- Replace the air filter element every 40000 km (2400 mi) of operation.
- The air filter needs more frequent service if you are riding in unusually wet or dusty areas.

# ENGINE

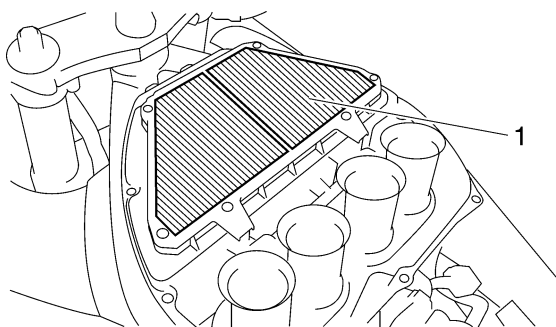

4. Install:
- Air filter element

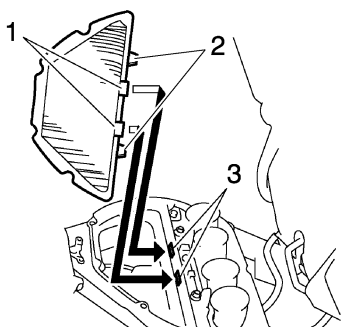

1. Projection 1
2. Projection 2
3. Slot

**NOTE:**  
Install a new air filter element by fitting the projections 1 on the element into the slots in the air filter case.

ECA4C81021

**CAUTION:**

- **Make sure that the air filter element is properly seated in the air filter case.**
- **Pay attention to handling of the products so that the projections is not deformed.**

5. Install:
- Air filter case cover

ECA4C81015

**CAUTION:**

**Never operate the engine without the air filter element installed. Unfiltered air will cause rapid wear of engine parts and may damage the engine. Operating the engine without the air filter element will also affect throttle bodies synchronization, leading to poor engine performance and possible overheating.**

**NOTE:**  
When installing the air filter element into the air filter case cover, make sure that the sealing surfaces are aligned to prevent any air leaks.

6. Install:
- Fuel tank
  - Fuel tank side covers  
Refer to "FUEL TANK" on page 7-1.
  - Rider seat  
Refer to "GENERAL CHASSIS" on page 4-1.

EAS21010

**CHECKING THE THROTTLE BODY JOINTS**

The following procedure applies to all of the throttle body joints and intake manifolds.

1. Remove:
  - Throttle bodies  
Refer to "THROTTLE BODIES" on page 7-4.
2. Check:
  - Throttle body joints "1"  
Cracks/damage → Replace.

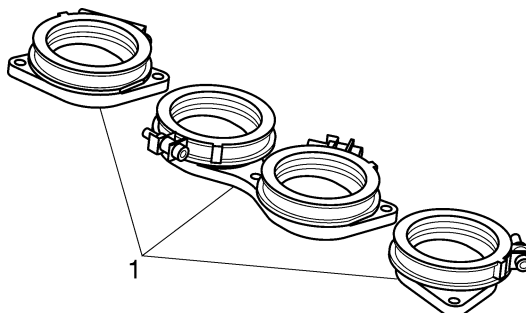

3. Install:
  - Throttle bodies  
Refer to "THROTTLE BODIES" on page 7-4.

EAS21030

**CHECKING THE FUEL LINE**

The following procedure applies to all of the fuel, vacuum and breather hoses.

1. Remove:
  - Rider seat  
Refer to "GENERAL CHASSIS" on page 4-1.
  - Fuel tank side covers
  - Fuel tank  
Refer to "FUEL TANK" on page 7-1.
2. Check:
  - Fuel hose "1"
  - Breather hose "2"  
Cracks/damage → Replace.  
Loose connection → Connect properly.

## ENGINE

**NOTE:**

Before removing the fuel hoses, place a few rags in the area under where it will be removing.

ECA14940

**CAUTION:**

**Make sure the fuel tank breather hose is routed correctly.**

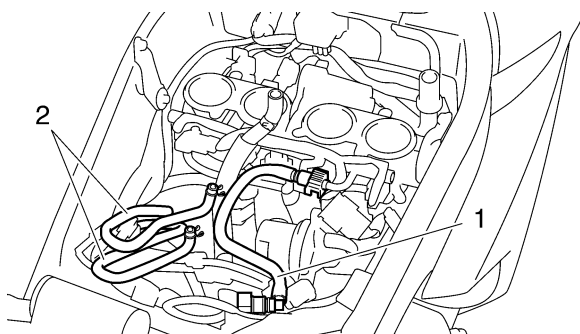

3. Install:
  - Fuel tank
  - Fuel tank side covers  
Refer to "FUEL TANK" on page 7-1.
  - Rider seat  
Refer to "GENERAL CHASSIS" on page 4-1.

ECA4C81016

**CAUTION:**

**To install the fuel tank, check that the breather hose is not folded or pinched by the fuel tank.**

EAS21070

**CHECKING THE CRANKCASE BREATHER HOSE**

1. Remove:
  - Rider seat  
Refer to "GENERAL CHASSIS" on page 4-1.
  - Fuel tank side covers
  - Fuel tank  
Refer to "FUEL TANK" on page 7-1.
2. Check:
  - Crankcase breather hose "1"  
Cracks/damage → Replace.  
Loose connection → Connect properly.

ECA13450

**CAUTION:**

**Make sure the crankcase breather hose is routed correctly.**

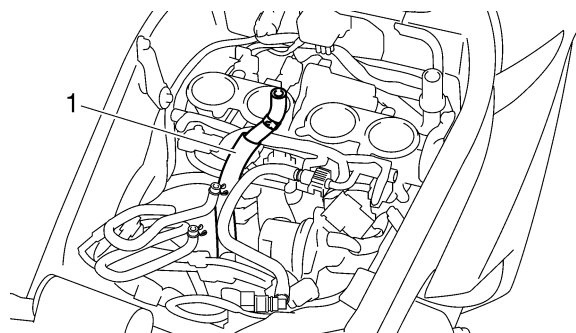

3. Install:
  - Fuel tank
  - Fuel tank side covers  
Refer to "FUEL TANK" on page 7-1.
  - Rider seat  
Refer to "GENERAL CHASSIS" on page 4-1.

ECA4C81016

**CAUTION:**

**To install the fuel tank, check that the breather hose is not folded or pinched by the fuel tank.**

EAS21080

**CHECKING THE EXHAUST SYSTEM**

The following procedure applies to all of the exhaust pipes and gaskets.

1. Check:
  - Exhaust pipe "1"
  - Exhaust valve pipe "2"
  - Muffler "3"  
Cracks/damage → Replace.
  - Gasket "4"  
Exhaust gas leaks → Replace.
  - Catalyst pipe "5"  
Cracks/damage → Replace.
2. Check:
  - Tightening torque
  - Exhaust pipe nut "6"
  - Exhaust pipe and exhaust valve pipe bolt "7"
  - Exhaust valve pipe and catalyst pipe bolt "8"
  - Catalyst pipe bolt "9"
  - Catalyst pipe and muffler bolt "10"
  - Muffler and frame bolt "11"



# ENGINE

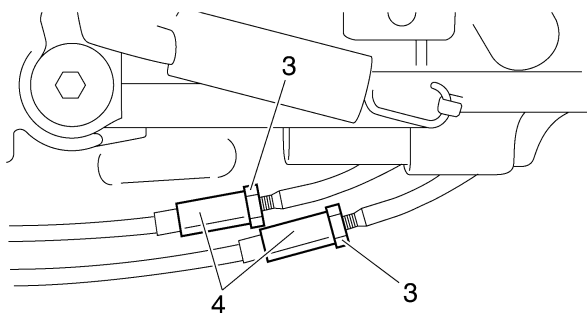

6. Install:
- EXUP valve pulley cover

	<p><b>EXUP valve pulley cover bolt</b>  <b>10 Nm (1.0 m·kg, 7.2 ft·lb)</b></p>
---	--

7. Install:
- Lower cowlings  
 Refer to "GENERAL CHASSIS" on page 4-1.

EAS28360

### CHECKING THE EXUP SERVO MOTOR

1. Check:
- EXUP servo motor operation  
 Out of specification → Replace.



- a. Check whether or not the EXUP valve is seized.
- Disconnect the EXUP cable and check that the EXUP valve is moved smoothly by hand.
  - When the valve is not moved smoothly, repair or replace it.  
 Refer to "ADJUSTING THE EXUP CABLES" on page 3-18.
- b. When the EXUP valve is moved smoothly, replace the EXUP servo motor.
- c. Perform the self-diagnosis mode and check the operation of EXUP valve by visual inspection (Code No: 53).  
 The operation should be carried out as 3-second drive in the full open direction, 2-second stop and 3-second drive in the full close direction.
- d. Check that the EXUP servo motor pulley rotates several times.



EAS21110

### CHECKING THE COOLANT LEVEL

1. Stand the vehicle on a level surface.

**NOTE:**

- Place the vehicle on a suitable stand.
- Make sure the vehicle is upright.

2. Remove:

- Lower cowlings
- Right side cowling

Refer to "GENERAL CHASSIS" on page 4-1.

3. Check:

- Coolant level

The coolant level should be between the maximum level mark "a" and minimum level mark "b".

Below the minimum level mark → Add the recommended coolant to the proper level.

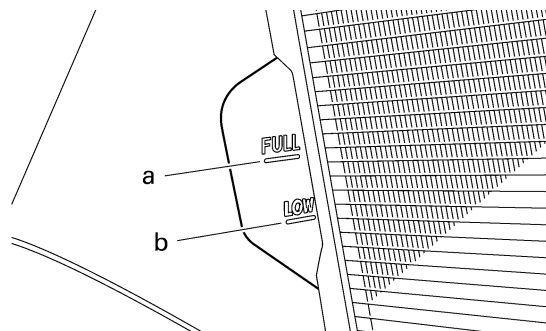

ECA13470

**CAUTION:**

- **Adding water instead of coolant lowers the antifreeze content of the coolant. If water is used instead of coolant check, and if necessary, correct the antifreeze concentration of the coolant.**
- **Use only distilled water. However, if distilled water is not available, soft water may be used.**

4. Start the engine, warm it up for several minutes, and then turn it off.

5. Check:

- Coolant level

**NOTE:**

Before checking the coolant level, wait a few minutes until it settles.

6. Install:

- Right side cowling
- Lower cowlings

Refer to "GENERAL CHASSIS" on page 4-1.

EAS21120

## CHECKING THE COOLING SYSTEM

1. Remove:
  - Lower cowlings
  - Side cowlings
 Refer to "GENERAL CHASSIS" on page 4-1.
2. Check:
  - Radiator "1"
  - Radiator inlet hose "2"
  - Radiator outlet hose "3"
  - Oil cooler "4"
  - Oil cooler inlet hose "5"
  - Oil cooler outlet hose "6"
  - Water jacket joint "7"
  - Water jacket joint inlet hose "8"
  - Water pump inlet pipe "9"
  - Water pump outlet pipe "10"
 Cracks/damage → Replace.  
 Refer to "RADIATOR" on page 6-1 and "OIL COOLER" on page 6-4.

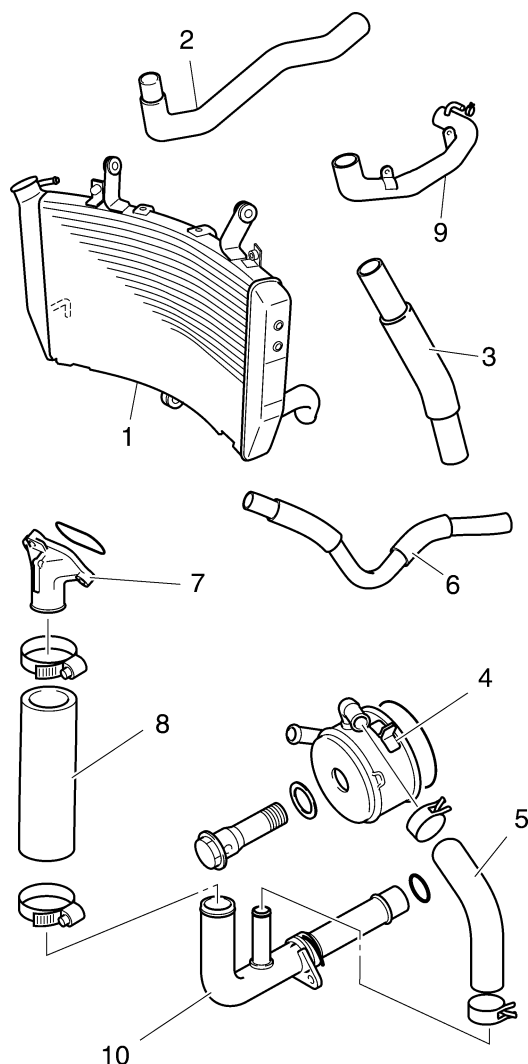

3. Install:

- Side cowlings
  - Lower cowlings
- Refer to "GENERAL CHASSIS" on page 4-1.

EAS21130

## CHANGING THE COOLANT

1. Remove:
  - Lower cowlings
  - Side cowlings
 Refer to "GENERAL CHASSIS" on page 4-1.
2. Remove:
  - Coolant reservoir
  - Coolant reservoir hose
3. Disconnect:
  - Coolant reservoir cap "1"
4. Drain:
  - Coolant (from the coolant reservoir)
5. Remove:
  - Radiator cap "2"

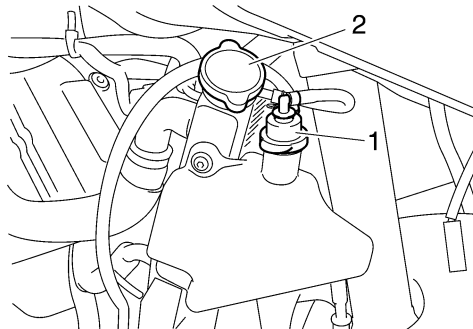

EWA13030

### **⚠ WARNING**

**A hot radiator is under pressure. Therefore, do not remove the radiator cap when the engine is hot. Scalding hot fluid and steam may be blown out, which could cause serious injury. When the engine has cooled, open the radiator cap as follows: Place a thick rag or a towel over the radiator cap and slowly turn the radiator cap counterclockwise toward the detent to allow any residual pressure to escape. When the hissing sound has stopped, press down on the radiator cap and turn it counterclockwise to remove.**

The following procedure applies to all of the coolant drain bolts and copper washers.

6. Remove:
  - Coolant drain bolt (engine) "1" (along with the copper washer)

## ENGINE

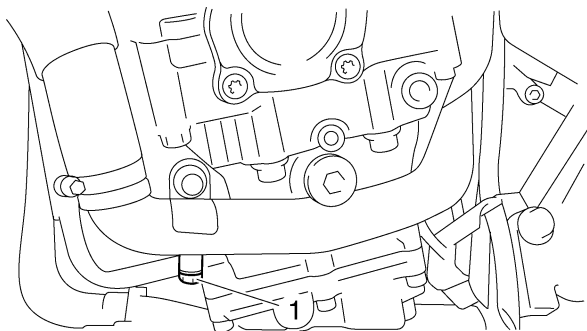

7. Drain:
  - Coolant (from the engine and radiator)
8. Check:
  - Copper washer "1" **New** (coolant drain bolt "2")

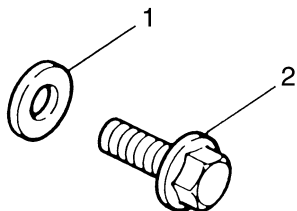

9. Install:
  - Coolant drain bolt (with the copper washer)

	<p><b>Coolant drain bolt</b>  <b>7 Nm (0.7 m·Kg, 5.1 ft·lb)</b></p>
--	---

10. Connect:
  - Coolant reservoir hose
11. Install:
  - Coolant reservoir
12. Fill:
  - Cooling system (with the specified amount of the recommended coolant)



**Recommended antifreeze**  
 High-quality ethylene glycol antifreeze containing corrosion inhibitors for aluminum engines

**Mixing ratio**

1:1 (antifreeze:water)

**Radiator capacity (including all routes)**

2.76 L (2.92 US qt) (2.43 Imp.qt)

**Coolant reservoir capacity (up to the maximum level mark)**

0.25 L (0.26 US qt) (0.22 Imp.qt)

Handling notes for coolant  
 Coolant is potentially harmful and should be handled with special care.

EWA13040

**WARNING**

- If coolant splashes in your eyes, thoroughly wash them with water and consult a doctor.
- If coolant splashes on your clothes, quickly wash it away with water and then with soap and water.
- If coolant is swallowed, induce vomiting and get immediate medical attention.

ECA13480

**CAUTION:**

- Adding water instead of coolant lowers the antifreeze content of the coolant. If water is used instead of coolant check, and if necessary, correct the antifreeze concentration of the coolant.
- Use only distilled water. However, if distilled water is not available, soft water may be used.
- If coolant comes into contact with painted surfaces, immediately wash them with water.
- Do not mix different types of antifreeze.

13. Install:

- Radiator cap

14. Fill:

- Coolant reservoir (with the recommended coolant to the maximum level mark "a")

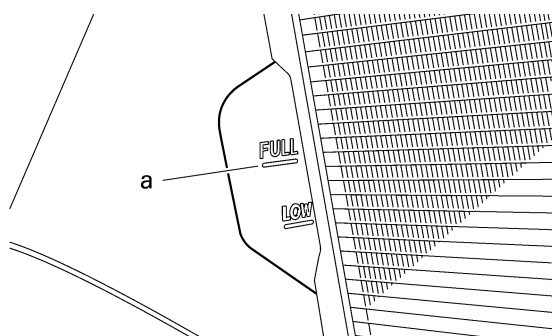

15. Install:

- Coolant reservoir cap

16. Start the engine, warm it up for several minutes, and then stop it.

17. Check:

- Coolant level

Refer to "CHECKING THE COOLANT LEVEL" on page 3-19.

**NOTE:**

Before checking the coolant level, wait a few minutes until the coolant has settled.

---

18. Install:

- Side cowlings
- Lower cowlings

Refer to "GENERAL CHASSIS" on page 4-1.

# CHASSIS

EAS21140

## CHASSIS

EAS21160

### ADJUSTING THE FRONT DISC BRAKE

1. Adjust:

- Brake lever position  
(distance "a" from the throttle grip to the brake lever)

**NOTE:**

While pushing the brake lever forward, turn the adjusting dial "1" until the brake lever is in the desired position.

**Direction "b"**  
Distance "a" is the largest.  
**Direction "c"**  
Distance "a" is the smallest.

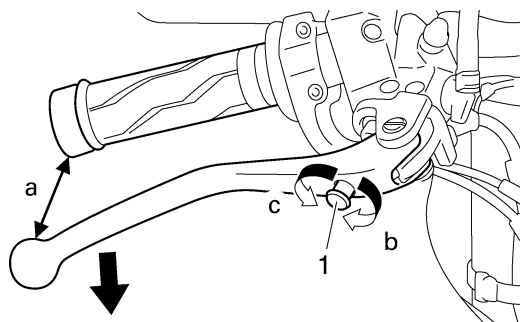

EWA13060

**WARNING**

- After adjusting the brake lever position, make sure the pin on the brake lever holder is firmly inserted in the hole in the adjusting dial.
- A soft or spongy feeling in the brake lever can indicate the presence of air in the brake system. Before the vehicle is operated, the air must be removed by bleeding the brake system. Air in the brake system will considerably reduce in loss of control and possibly an accident. Therefore, check and if necessary, bleed the brake system.

ECA13490

**CAUTION:**

After adjusting the brake lever position, make sure there is no brake drag.

EAS21190

### ADJUSTING THE REAR DISC BRAKE

1. Check:

- Brake pedal position

(distance "a" from the center of the footrest bracket bolt to the center of the brake pedal)

Out of specification → Adjust.

 **Brake pedal position**  
**25.2 mm (0.99 in)**

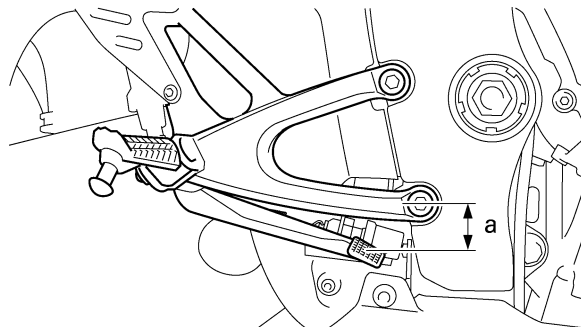

2. Adjust:

- Brake pedal position



- Loosen the locknut "1".
- Turn the adjusting bolt "2" in direction "a" or "b" until the specified brake pedal position is obtained.

**Direction "a"**  
Brake pedal is raised.  
**Direction "b"**  
Brake pedal is lowered.

EWA13070

**WARNING**

After adjusting the brake pedal position, check that the end of the adjusting bolt "c" is visible through the hole "d".

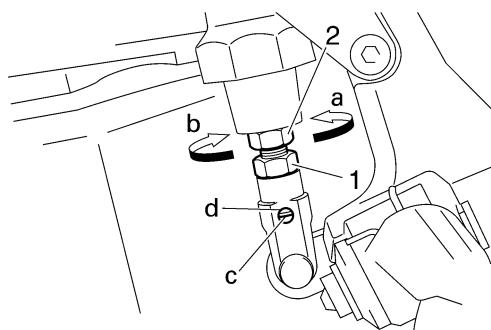

c. Tighten the locknut "1" to specification.

 **Locknut**  
**18 Nm (1.8 m·kg, 13 ft·lb)**

# CHASSIS

EWA13050

**⚠ WARNING**

A soft or spongy feeling in the brake lever can indicate the presence of air in the brake system. Before the vehicle is operated, the air must be removed by bleeding the brake system. Air in the brake system will considerably reduce braking performance.

ECA13510

**CAUTION:**

After adjusting the brake pedal position, make sure there is no brake drag.



3. Adjust:
- Rear brake light switch  
Refer to "ADJUSTING THE REAR BRAKE LIGHT SWITCH" on page 3-25.

EAS21240

**CHECKING THE BRAKE FLUID LEVEL**

1. Stand the vehicle on a level surface.

**NOTE:**

- Place the vehicle on a suitable stand.
  - Make sure the vehicle is upright.
2. Check:
    - Brake fluid level  
Below the minimum level mark "a" → Add the recommended brake fluid to the proper level.

	<b>Recommended fluid DOT 4</b>
--	------------------------------------

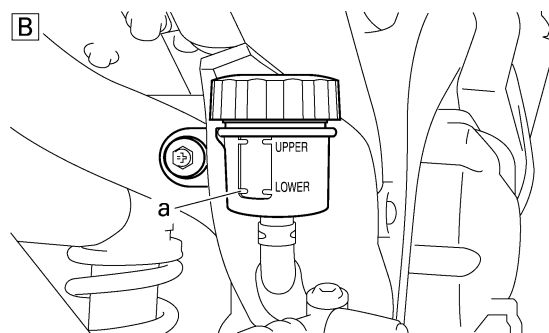
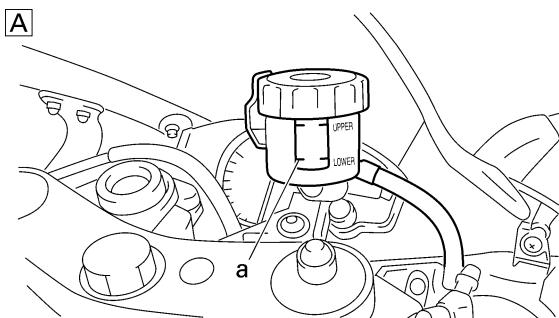

- A. Front brake
- B. Rear brake

EWA13090

**⚠ WARNING**

- Use only the designated brake fluid. Other brake fluids may cause the rubber seals to deteriorate, causing leakage and poor brake performance.
- Refill with the same type of brake fluid that is already in the system. Mixing brake fluids may result in a harmful chemical reaction, leading to poor brake performance.
- When refilling, be careful that water does not enter the brake fluid reservoir. Water will significantly lower the boiling point of the brake fluid and could cause vapor lock.

ECA13540

**CAUTION:**

Brake fluid may damage painted surfaces and plastic parts. Therefore, always clean up any spilt brake fluid immediately.

**NOTE:**

In order to ensure a correct reading of the brake fluid level, make sure the top of the brake fluid reservoir is horizontal.

EAS21250

**CHECKING THE FRONT BRAKE PADS**

The following procedure applies to all of the brake pads.

1. Operate the brake.
2. Check:
  - Front brake pad  
Wear indicators "a" almost touch the brake disc → Replace the brake pads as a set. Refer to "FRONT BRAKE" on page 4-20.

# CHASSIS

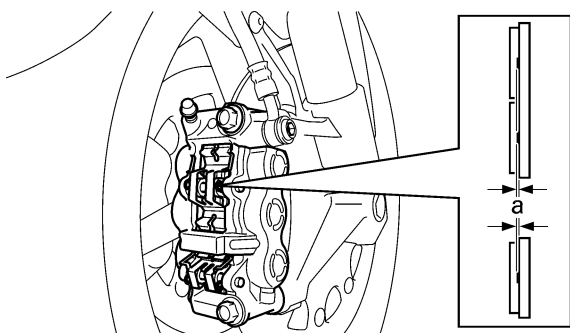

EAS21260

### CHECKING THE REAR BRAKE PADS

The following procedure applies to all of the brake pads.

1. Operate the brake.
2. Check:
  - Rear brake pad  
Wear indicators "a" almost touch the brake disc → Replace the brake pads as a set. Refer to "REAR BRAKE" on page 4-33.

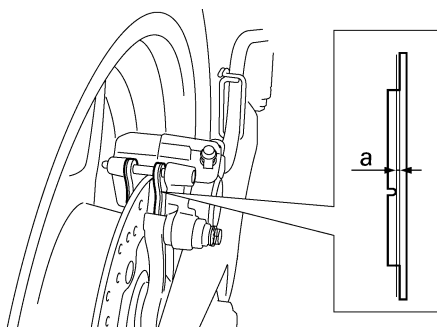

EAS21280

### CHECKING THE FRONT BRAKE HOSES

The following procedure applies to all of the brake hoses and brake hose clamps.

1. Check:
  - Brake hose "1"  
Cracks/damage/wear → Replace.
2. Check:
  - Brake hose clamp "2"  
Loose → Tighten the clamp bolt.

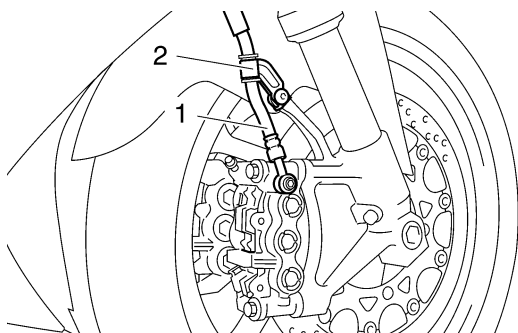

3. Hold the vehicle upright and apply the brake several times.
4. Check:
  - Brake hose  
Brake fluid leakage → Replace the damaged hose. Refer to "FRONT BRAKE" on page 4-20.

EAS21290

### CHECKING THE REAR BRAKE HOSE

1. Check:
  - Brake hose "1"  
Cracks/damage/wear → Replace.
2. Check:
  - Brake hose clamp "2"  
Loose Connection → Tighten the clamp bolt.

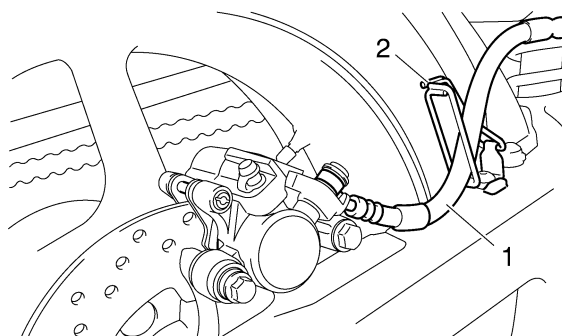

3. Hold the vehicle upright and apply the front brake several times.
4. Check:
  - Brake hose  
Brake fluid leakage → Replace the damaged hose. Refer to "REAR BRAKE" on page 4-33.

EAS21330

### ADJUSTING THE REAR BRAKE LIGHT SWITCH

**NOTE:** \_\_\_\_\_  
The rear brake light switch is operated by movement of the brake pedal. The rear brake light switch is properly adjusted when the brake light comes on just before the braking effect starts.

1. Check:
  - Rear brake light operation timing  
Incorrect → Adjust.
2. Adjust:
  - Rear brake light operation timing



# CHASSIS

- a. Hold the main body "1" of the rear brake light switch so that it does not rotate and turn the adjusting nut "2" in direction "a" or "b" until the rear brake light comes on at the proper time.

**Direction "a"**  
 Brake light comes on sooner.  
**Direction "b"**  
 Brake light comes on later.

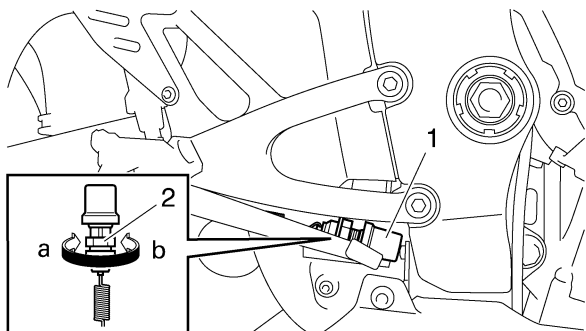

EAS21360  
**BLEEDING THE HYDRAULIC BRAKE SYSTEM**

EWA13100  
**WARNING**

Bleed the hydraulic brake system whenever:

- The system is disassembled.
- A brake hose is loosened, disconnected or replaced.
- The brake fluid level is very low.
- Brake operation is faulty.

**NOTE:**

- Be careful not to spill any brake fluid or allow the brake fluid reservoir to overflow.
- When bleeding the hydraulic brake system, make sure there is always enough brake fluid before applying the brake. Ignoring this precaution could allow air to enter the hydraulic brake system, considerably lengthening the bleeding procedure.
- If bleeding is difficult, it may be necessary to let the brake fluid settle for a few hours. Repeat the bleeding procedure when the tiny bubbles in the hose have disappeared.

1. Bleed:
  - Hydraulic brake system



- a. Fill the brake fluid reservoir to the proper level with the recommended brake fluid.

- b. Install the brake fluid reservoir diaphragm.
- c. Connect a clear plastic hose "1" tightly to the bleed screw "2".

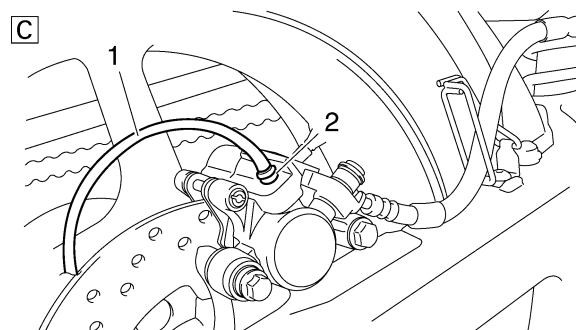
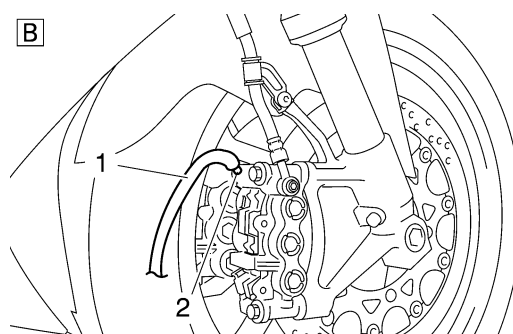
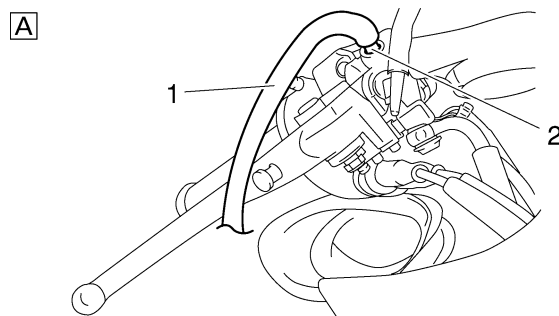

- A. Front brake master cylinder  
 B. Front brake caliper  
 C. Rear brake caliper

**NOTE:**

Bleeding order of the front hydraulic brake system is the following order:

- Front brake master cylinder
- Front brake calipers
- Front brake master cylinder

- d. Place the other end of the hose into a container.
- e. Slowly apply the brake several times.
- f. Fully pull the brake lever or fully press down the brake pedal and hold it in position.

# CHASSIS

g. Loosen the bleed screw.

**NOTE:**

Loosening the bleed screw will release the pressure and cause the brake lever to contact the throttle grip or the brake pedal to fully extend.

- h. Tighten the bleed screw and then release the brake lever or brake pedal.
- i. Repeat steps (e) to (h) until all of the air bubbles have disappeared from the brake fluid in the plastic hose.
- j. Tighten the bleed screw to specification.

	<p><b>Bleed screw</b>  <b>6 Nm (0.6 m·kg, 4.3 ft·lb)</b></p>
---	--

k. Fill the brake fluid reservoir to the proper level with the recommended brake fluid. Refer to "CHECKING THE BRAKE FLUID LEVEL" on page 3-24.

EWA13110

**WARNING**

**After bleeding the hydraulic brake system, check the brake operation.**



EAS21380

**ADJUSTING THE SHIFT PEDAL**

- 1. Adjust:
  - Shift pedal position



- a. Loosen both locknuts "1".
- b. Turn the shift rod "2" in direction "a" or "b" to obtain the correct shift pedal position.

<p><b>Direction "a"</b>                  Shift pedal is raised.</p> <p><b>Direction "b"</b>                  Shift pedal is lowered.</p>
--

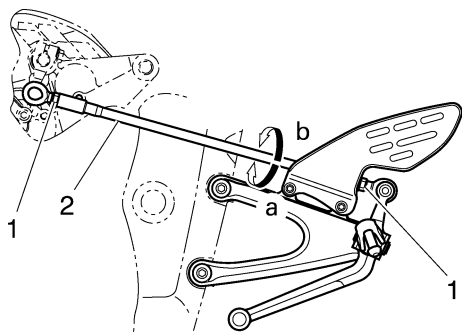

c. Tighten both locknuts.



EAS21410

**ADJUSTING THE DRIVE CHAIN SLACK**

**NOTE:**

The drive chain slack must be checked at the tightest point on the chain.

ECA13550

**CAUTION:**

**A drive chain that is too tight will overload the engine and other vital parts, and one that is too loose can skip and damage the swingarm or cause an accident. Therefore, keep the drive chain slack within the specified limits.**

- 1. Stand the vehicle on a level surface.

EWA13120

**WARNING**

**Securely support the vehicle so that there is no danger of it falling over.**

**NOTE:**

Place the vehicle on a suitable stand so that the rear wheel is elevated.

- 2. Spin the rear wheel several times and find the tightest position of drive chain.
- 3. Check:
  - Drive chain slack "a"
 Out of specification → Adjust.

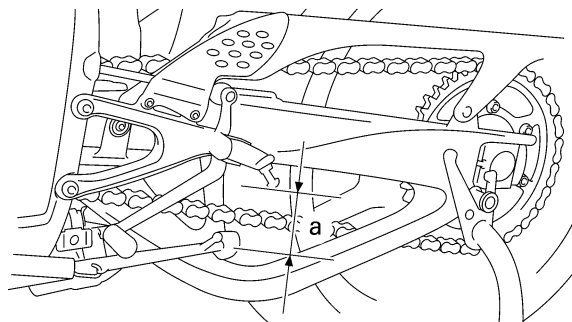

	<p><b>Drive chain slack</b>  <b>30.0–40.0 mm (1.18–1.57 in)</b></p>
---	---

- 4. Adjust:
  - Drive chain slack



- a. Loosen the wheel axle nut "1".
- b. Loosen both locknuts "2".
- c. Turn both adjusting nuts "3" in direction "a" or "b" until the specified drive chain slack is obtained.

# CHASSIS

**Direction “a”**  
Drive chain is tightened.  
**Direction “b”**  
Drive chain is loosened.

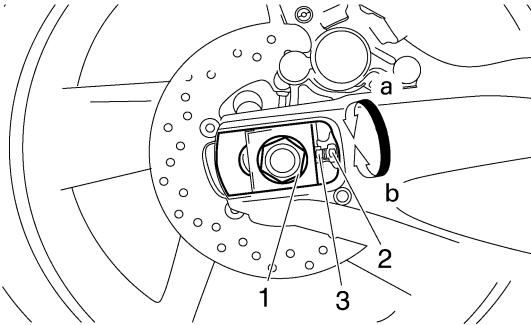

**NOTE:**  
To maintain the proper wheel alignment, adjust both sides evenly.

d. Tighten both locknuts to specification.

	<b>Locknut</b> <b>16 Nm (1.6 m·kg, 12 ft·lb)</b>
---	---

e. Tighten the wheel axle nut to specification.

	<b>Wheel axle nut</b> <b>150 Nm (15 m·kg, 108 ft·lb)</b>
---	---

EAS21440

## LUBRICATING THE DRIVE CHAIN

The drive chain consists of many interacting parts. If the drive chain is not maintained properly, it will wear out quickly. Therefore, the drive chain should be serviced, especially when the vehicle is used in dusty areas.

This vehicle has a drive chain with small rubber O-rings between each side plate. Steam cleaning, high-pressure washing, certain solvents, and the use of a coarse brush can damage these O-rings. Therefore, use only kerosene to clean the drive chain. Wipe the drive chain dry and thoroughly lubricate it with engine oil or chain lubricant that is suitable for O-ring chains. Do not use any other lubricants on the drive chain since they may contain solvents that could damage the O-rings.

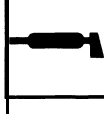
	<b>Recommended lubricant</b> <b>Engine oil or chain lubricant</b> <b>suitable for O-ring chains</b>
---	---

EAS21500

## CHECKING AND ADJUSTING THE STEERING HEAD

1. Stand the vehicle on a level surface.

EWA13120

### **WARNING**

**Securely support the vehicle so that there is no danger of it falling over.**

**NOTE:**

Place the vehicle on a suitable stand so that the front wheel is elevated.

2. Check:

- Steering head  
Grasp the bottom of the front fork legs and gently rock the front fork.  
Binding/looseness → Adjust the steering head.

3. Remove:

- Upper bracket  
Refer to "HANDLEBARS" on page 4-45 and "STEERING HEAD" on page 4-59.

4. Adjust:

- Steering head



a. Remove the lock washer “1”, the upper ring nut “2”, and the rubber washer “3”.

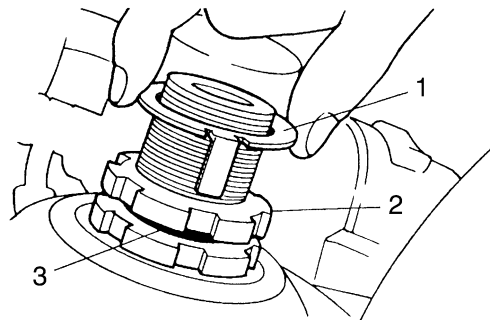

b. Loosen the lower ring nut “4” and then tighten it to specification with a steering nut wrench “5”.

**NOTE:**

Set the torque wrench at a right angle to the steering nut wrench.

# CHASSIS



**Steering nut wrench**  
 90890-01403  
**Spanner wrench**  
 YU-33975



**Lower ring nut (initial tightening torque)**  
 52 Nm (5.2 m·kg, 38 ft·lb)

c. Loosen the lower ring nut "4" completely, then tighten it to specification.

EWA13140



**WARNING**

**Do not overtighten the lower ring nut.**



**Lower ring nut (final tightening torque)**  
 18 Nm (1.8 m·kg, 13 ft·lb)

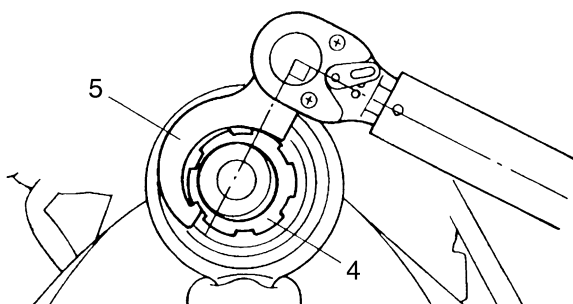

- d. Check the steering head for looseness or binding by turning the front fork all the way in both directions. If any binding is felt, remove the lower bracket and check the upper and lower bearings. Refer to "STEERING HEAD" on page 4-59.
- e. Install the rubber washer "3".
- f. Install the upper ring nut "2".
- g. Finger tighten the upper ring nut "2", then align the slots of both ring nuts. If necessary, hold the lower ring nut and tighten the upper ring nut until their slots are aligned.
- h. Install the lock washer "1".

**NOTE:**

Make sure the lock washer tabs "a" sit correctly in the ring nut slots "b".

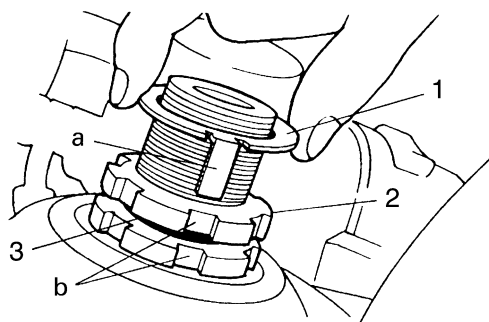

- 5. Install:
  - Upper bracket  
 Refer to "STEERING HEAD" on page 4-59.
- 6. Measure:
  - Steering head tension



**NOTE:**

Make sure all of the cables and wires are properly routed.

- a. Point the front wheel straight ahead.
- b. Install a plastic locking tie "1" loosely around the end of the handlebar as shown.
- c. Hook a spring gauge "2" onto the plastic locking tie.

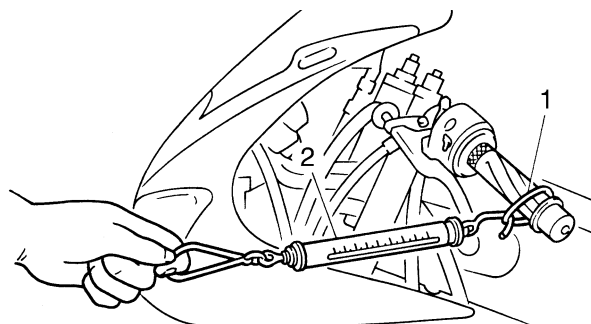

- d. Hold the spring gauge at a 90° angle from the handlebar, pull the spring gauge, and then record the measurement when the handlebar starts to run.



**Steering head tension**  
 200–500 g

# CHASSIS

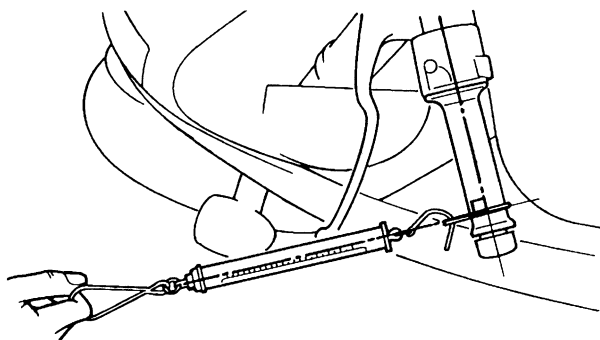

- e. Repeat the above procedure on the opposite handlebar.
- f. If the steering head tension is out of specification (both handlebars should be within specification), remove the upper bracket and loosen or tighten the upper ring nut.
- g. Reinstall the upper bracket and measure the steering head tension again as described above.
- h. Repeat the above procedure until the steering head tension is within specification.
- i. Grasp the bottom of the front fork legs and gently rock the front fork.  
Binding/looseness → Adjust the steering head.



EAS21530

### CHECKING THE FRONT FORK

1. Stand the vehicle on a level surface.

EWA13120



**Securely support the vehicle so that there is no danger of it falling over.**

2. Check:
  - Inner tube "1"
  - Damage/scratches → Replace.
  - Oil seal "2"
  - Oil leakage → Replace.

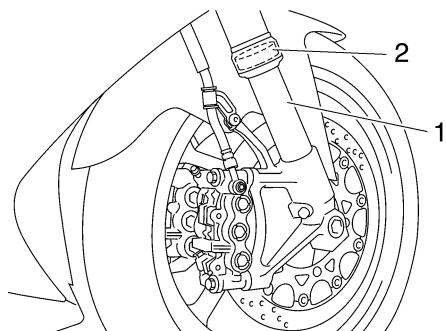

3. Hold the vehicle upright and apply the front brake.

4. Check:
  - Front fork operation  
Push down hard on the handlebar several times and check if the front fork rebounds smoothly.  
Rough movement → Repair.  
Refer to "FRONT FORK" on page 4-50.

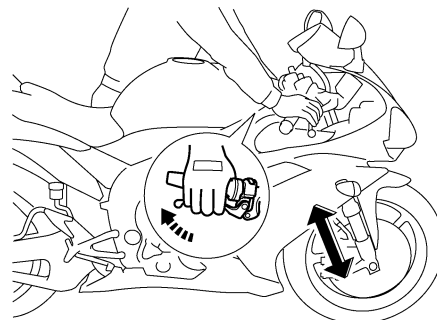

EAS21580

### ADJUSTING THE FRONT FORK LEGS

The following procedure applies to both of the front fork legs.

EWA13150



- **Always adjust both front fork legs evenly. Uneven adjustment can result in poor handling and loss of stability.**
- **Securely support the vehicle so that there is no danger of it falling over.**

### Spring preload

ECA13570



- Grooves are provided to indicate the adjustment position.
- Never go beyond the maximum or minimum adjustment positions.

1. Adjust:
  - Spring preload

- a. Turn the adjusting bolt "1" in direction "a" or "b".

**Direction "a"**  
Spring preload is increased (suspension is harder).

**Direction "b"**  
Spring preload is decreased (suspension is softer).

# CHASSIS

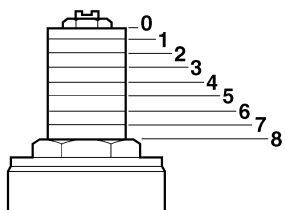
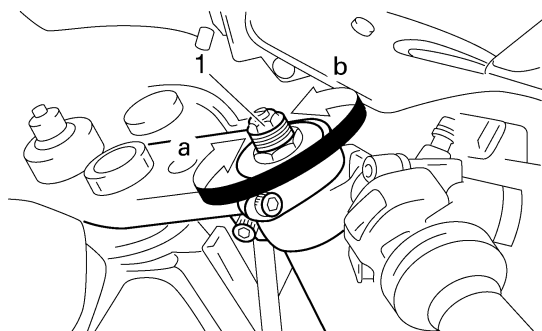

### Rebound damping adjust positions

- Minimum  
26 click(s) out\*
- Standard  
10 click(s) out\*
- Maximum  
1 click(s) out\*

\* With the adjusting screw fully turned in.

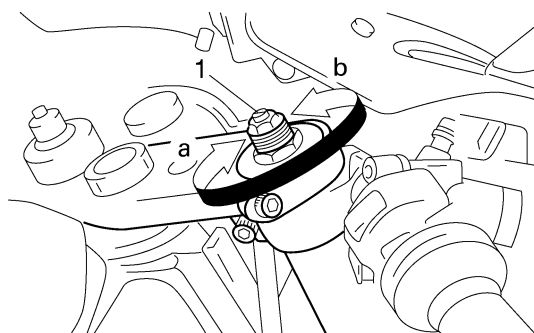

### Spring preload adjusting positions

- Minimum  
8
- Standard  
5
- Maximum  
0

### Compression damping

ECA13590

**CAUTION:** \_\_\_\_\_

Never go beyond the maximum or minimum adjustment positions.

1. Adjust:
  - Compression damping

- a. Turn the adjusting screw "1" in direction "a" or "b".

**Direction "a"**  
Compression damping is increased (suspension is harder).

**Direction "b"**  
Compression damping is decreased (suspension is softer).

### Rebound damping

ECA13590

**CAUTION:** \_\_\_\_\_

Never go beyond the maximum or minimum adjustment positions.

1. Adjust:
  - Rebound damping

- a. Turn the adjusting screw "1" in direction "a" or "b".

**Direction "a"**  
Rebound damping is increased (suspension is harder).

**Direction "b"**  
Rebound damping is decreased (suspension is softer).



### Compression damping adjust points

- Minimum  
25 click(s) out\*
- Standard  
10 click(s) out\*
- Maximum  
1 click(s) out\*

\* With the adjusting screw fully turned in.

# CHASSIS

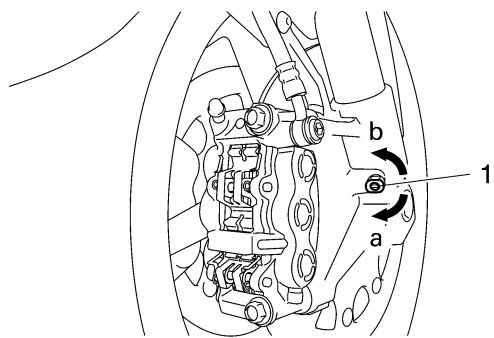

EAS21610  
**ADJUSTING THE REAR SHOCK  
 ABSORBER ASSEMBLY**

EWA13120

**⚠ WARNING**

**Securely support the vehicle so that there is no danger of it falling over.**

**Spring preload**

ECA13590

**CAUTION:**

**Never go beyond the maximum or minimum adjustment positions.**

1. Adjust:
  - Spring preload



- a. Adjust the spring preload with the special wrench and extension bar included in the owner's tool kit.
- b. Turn the adjusting ring "1" in direction "a" or "b".
- c. Align the desired position on the adjusting ring with the stopper "2".

**Direction "a"**  
 Spring preload is increased (suspension is harder).

**Direction "b"**  
 Spring preload is decreased (suspension is softer).

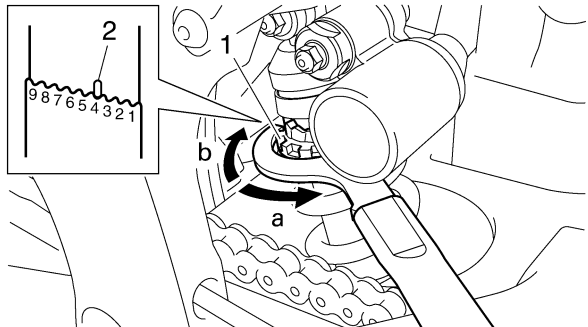

**Spring preload adjusting positions**

**Minimum**  
1

**Standard**  
5

**Maximum**  
9



**Rebound damping**

ECA13590

**CAUTION:**

**Never go beyond the maximum or minimum adjustment positions.**

1. Adjust:
  - Rebound damping



- a. Turn the adjusting knob "1" in direction "a" or "b".

**Direction "a"**  
 Rebound damping is increased (suspension is harder).

**Direction "b"**  
 Rebound damping is decreased (suspension is softer).

**Rebound damping adjust positions**

**Minimum**  
20 click(s) out\*

**Standard**  
12 click(s) out\*

**Maximum**  
3 click(s) out\*

**\* With the adjusting screw fully turned in.**

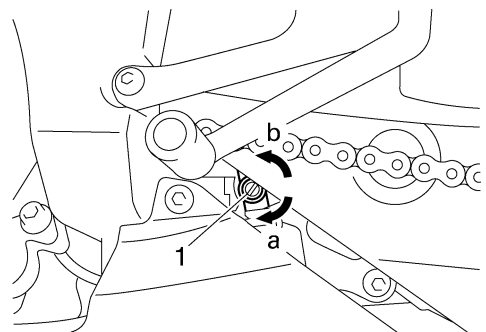

# CHASSIS

## Compression damping (fast compression damping)

ECA13590

**CAUTION:**

Never go beyond the maximum or minimum adjustment positions.

1. Adjust:
  - Compression damping (fast compression damping)

- a. Turn the adjusting screw "1" in direction "a" or "b".

**Direction "a"**  
 Compression damping is increased (suspension is harder).  
**Direction "b"**  
 Compression damping is decreased (suspension is softer).



### Compression damping (fast compression damping) adjusting positions

**Minimum**  
 4 turn(s) out\*  
**Standard**  
 3 turn(s) out\*  
**Maximum**  
 0 turn(s) out\*

\* With the adjusting screw fully turned in.

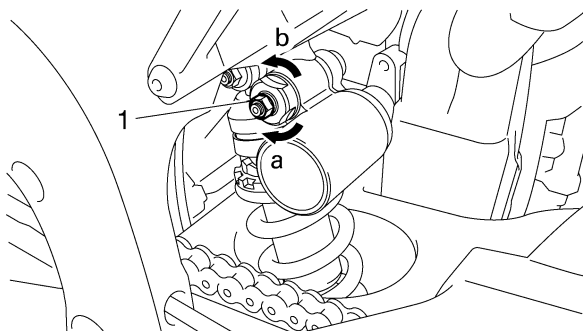

## Compression damping (slow compression damping)

ECA13590

**CAUTION:**

Never go beyond the maximum or minimum adjustment positions.

1. Adjust:
  - Compression damping (slow compression damping)

- a. Turn the adjusting knob "1" in direction "a" or "b".

**Direction "a"**  
 Compression damping is increased (suspension is harder).  
**Direction "b"**  
 Compression damping is decreased (suspension is softer).



### Compression damping (slow compression damping) adjusting positions

**Minimum**  
 20 click(s) out\*  
**Standard**  
 12 click(s) out\*  
**Maximum**  
 1 click(s) out\*

\* With the adjusting screw fully turned in.

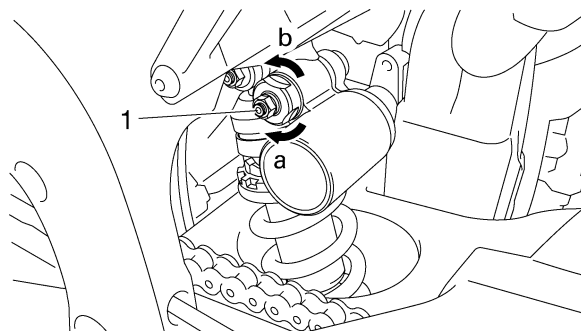

EAS21650

## CHECKING THE TIRES

The following procedure applies to both of the tires.

1. Check:
  - Tire pressure  
 Out of specification → Regulate.

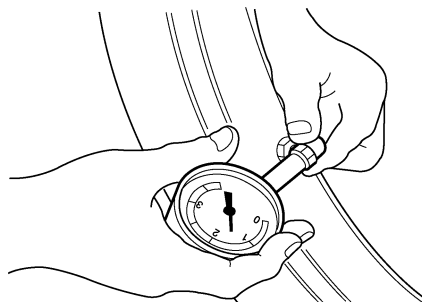

# CHASSIS

EWA13180

**⚠ WARNING**

- The tire pressure should only be checked and regulated when the tire temperature equals the ambient air temperature.
- The tire pressure and the suspension must be adjusted according to the total weight (including cargo, rider, passenger and accessories) and the anticipated riding speed.
- Operation of an overloaded vehicle could cause tire damage, an accident or an injury.

**NEVER OVERLOAD THE VEHICLE.**



Tire air pressure (measured on cold tires)

Loading condition  
0–90 kg (0–198 lb)

Front  
250 kPa (36 psi) (2.50 kgf/cm<sup>2</sup>)  
(2.50 bar)

Rear  
290 kPa (42 psi) (2.90 kgf/cm<sup>2</sup>)  
(2.90 bar)

Loading condition  
90–195 kg (198–430 lb)

Front  
250 kPa (36 psi) (2.50 kgf/cm<sup>2</sup>)  
(2.50 bar)

Rear  
290 kPa (42 psi) (2.90 kgf/cm<sup>2</sup>)  
(2.90 bar)

High-speed riding

Front  
250 kPa (36 psi) (2.50 kgf/cm<sup>2</sup>)  
(2.50 bar)

Rear  
290 kPa (42 psi) (2.90 kgf/cm<sup>2</sup>)  
(2.90 bar)

Maximum load  
195 kg (430 lb)

\* Total weight of rider, passenger, cargo and accessories

EWA13190

**⚠ WARNING**

It is dangerous to ride with a worn-out tire. When the tire tread reaches the wear limit, replace the tire immediately.

2. Check:
- Tire surfaces

Damage/wear → Replace the tire.

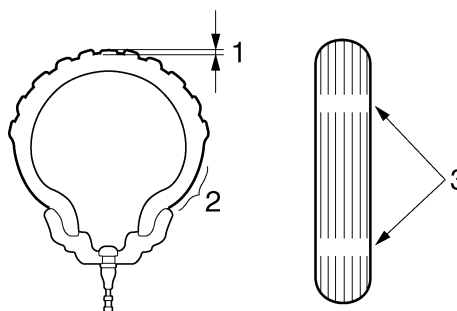

1. Tire tread depth
2. Side wall
3. Wear indicator



Wear limit (front)  
0.8 mm (0.03 in)  
Wear limit (rear)  
0.8 mm (0.03 in)

EWA14080

**⚠ WARNING**

- Do not use a tubeless tire on a wheel designed only for tube tires to avoid tire failure and personal injury from sudden deflation.
- When using a tube tire, be sure to install the correct tube.
- Always replace a new tube tire and a new tube as a set.
- To avoid pinching the tube, make sure the wheel rim band and tube are centered in the wheel groove.
- Patching a punctured tube is not recommended. If it is absolutely necessary to do so, use great care and replace the tube as soon as possible with a good quality replacement.

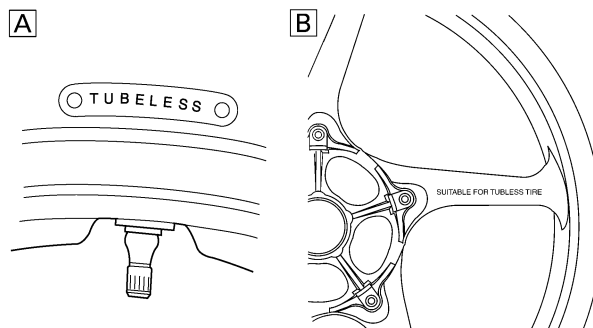

- A. Tire
- B. Wheel

Tube wheel	Tube tire only
Tubeless wheel	Tube or tubeless tire

## CHASSIS

EWA14090

### WARNING

After extensive tests, the tires listed below have been approved by Yamaha Motor Co., Ltd. for this model. The front and rear tires should always be by the same manufacturer and of the same design. No guarantee concerning handling characteristics can be given if a tire combination other than one approved by Yamaha is used on this vehicle.



#### Front tire

##### Size

120/70 ZR17M/C (58W)

##### Manufacturer/model

MICHELIN/Pilot POWER P

##### Manufacturer/model

PIRELLI/DIABLO CORSA E



#### Rear tire

##### Size

190/50 ZR17M/C (73W)

##### Manufacturer/model

MICHELIN/ Pilot POWER

##### Manufacturer/model

PIRELLI/DIABLO CORSA L

EWA13210

### WARNING

New tires have a relatively low grip on the road surface until they have been slightly worn. Therefore, approximately 100 km should be traveled at normal speed before any high-speed riding is done.

#### NOTE:

For tires with a direction of rotation mark "1":

- Install the tire with the mark pointing in the direction of wheel rotation.
- Align the mark "2" with the valve installation point.

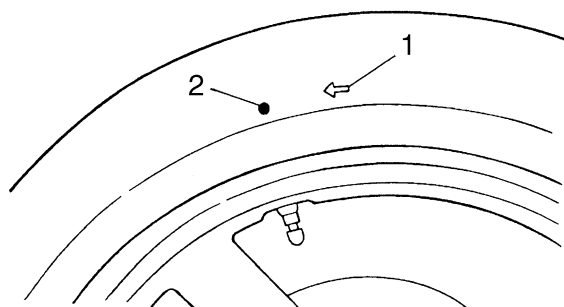

EAS21670

### CHECKING THE WHEELS

The following procedure applies to both of the wheels.

1. Check:
  - Wheel  
Damage/out-of-round → Replace.

EWA13260

### WARNING

Never attempt to make any repairs to the wheel.

#### NOTE:

After a tire or wheel has been changed or replaced, always balance the wheel.

EAS21690

### CHECKING AND LUBRICATING THE CABLES

The following procedure applies to all of the inner and outer cables.

EWA13270

### WARNING

Damaged outer cable may cause the cable to corrode and interfere with its movement. Replace damaged outer cable and inner cables as soon as possible.

1. Check:
  - Outer cable  
Damage → Replace.
2. Check:
  - Cable operation  
Rough movement → Lubricate.

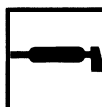

**Recommended lubricant**  
Engine oil or a suitable cable lubricant

#### NOTE:

Hold the cable end upright and pour a few drops of lubricant into the cable sheath or use a suitable lubricating device.

EAS21700

### LUBRICATING THE LEVERS

Lubricate the pivoting point and metal-to-metal moving parts of the levers.

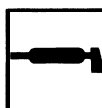

**Recommended lubricant**  
Lithium-soap-based grease

EAS21710

### LUBRICATING THE PEDAL

Lubricate the pivoting point and metal-to-metal moving parts of the pedal.

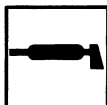

**Recommended lubricant**  
**Lithium-soap-based grease**

EAS21720

### LUBRICATING THE SIDESTAND

Lubricate the pivoting point and metal-to-metal moving parts of the sidestand.



**Recommended lubricant**  
**Lithium-soap-based grease**

EAS21740

### LUBRICATING THE REAR SUSPENSION

Lubricate the pivoting point and metal-to-metal moving parts of the rear suspension.

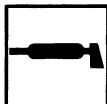

**Recommended lubricant**  
**Molybdenum disulfide grease**

## ELECTRICAL SYSTEM

EAS21750

### ELECTRICAL SYSTEM

EAS21760

#### CHECKING AND CHARGING THE BATTERY

Refer to "ELECTRICAL COMPONENTS" on page 8-81.

EAS21770

#### CHECKING THE FUSES

Refer to "ELECTRICAL COMPONENTS" on page 8-81.

EAS21790

#### REPLACING THE HEADLIGHT BULBS

The following procedure applies to both of the headlight bulbs.

1. Remove:
  - Intake air duct panel  
Refer to "GENERAL CHASSIS" on page 4-1.
2. Remove:
  - Headlight bulb coupler (high beam) "1"
  - Headlight bulb cover "2"

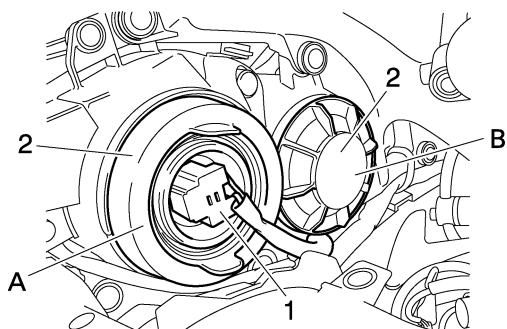

- A. High beam
- B. Low beam

3. Disconnect:
  - Headlight bulb coupler (low beam) "1"

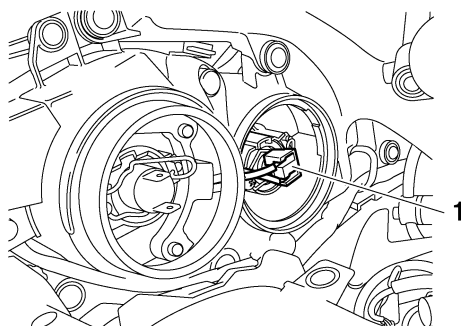

4. Remove:
  - Headlight bulb holders "3"

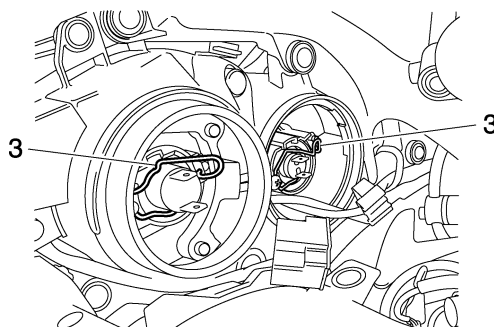

5. Remove:
  - Headlight bulb

EWA13320



Since the headlight bulb gets extremely hot, keep flammable products and your hands away from the bulb until it has cooled down.

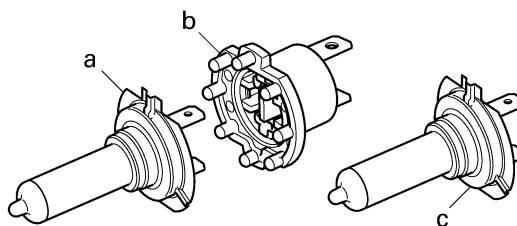

- a. High beam
- b. High beam bulb socket
- c. Low beam

6. Install:
  - Headlight bulb **New**  
Secure the new headlight bulbs with the headlight bulb holder.

ECA13690



Avoid touching the glass part of the headlight bulb to keep it free from oil, otherwise the transparency of the glass, the life of the bulb and the luminous flux will be adversely affected. If the headlight bulb gets soiled, thoroughly clean it with a cloth moistened with alcohol or lacquer thinner.

7. Install:
  - Headlight bulb holder
8. Connect:
  - Headlight bulb coupler (low beam)



## **ELECTRICAL SYSTEM**

---

---

## CHASSIS

<b>GENERAL CHASSIS</b> .....	4-1
REMOVING THE COVER.....	4-7
INSTALLING THE COVER .....	4-7
<b>FRONT WHEEL</b> .....	4-8
REMOVING THE FRONT WHEEL .....	4-10
CHECKING THE FRONT WHEEL.....	4-10
ADJUSTING THE FRONT WHEEL STATIC BALANCE .....	4-11
INSTALLING THE FRONT WHEEL .....	4-12
<b>REAR WHEEL</b> .....	4-14
REMOVING THE REAR WHEEL .....	4-17
CHECKING THE REAR WHEEL .....	4-17
CHECKING THE REAR WHEEL DRIVE HUB .....	4-18
CHECKING AND REPLACING THE REAR WHEEL SPROCKET .....	4-18
ADJUSTING THE REAR WHEEL STATIC BALANCE.....	4-18
INSTALLING THE REAR WHEEL .....	4-18
<b>FRONT BRAKE</b> .....	4-20
INTRODUCTION .....	4-25
CHECKING THE FRONT BRAKE DISCS .....	4-25
REPLACING THE FRONT BRAKE PADS .....	4-26
REMOVING THE FRONT BRAKE CALIPERS.....	4-27
DISASSEMBLING THE FRONT BRAKE CALIPERS.....	4-28
CHECKING THE FRONT BRAKE CALIPERS .....	4-28
ASSEMBLING THE FRONT BRAKE CALIPERS.....	4-28
INSTALLING THE FRONT BRAKE CALIPERS.....	4-29
REMOVING THE FRONT BRAKE MASTER CYLINDER.....	4-30
CHECKING THE FRONT BRAKE MASTER CYLINDER .....	4-30
ASSEMBLING THE FRONT BRAKE MASTER CYLINDER.....	4-31
INSTALLING THE FRONT BRAKE MASTER CYLINDER .....	4-31
<b>REAR BRAKE</b> .....	4-33
INTRODUCTION .....	4-38
CHECKING THE REAR BRAKE DISC.....	4-38
REPLACING THE REAR BRAKE PADS .....	4-38
REMOVING THE REAR BRAKE CALIPER.....	4-40
DISASSEMBLING THE REAR BRAKE CALIPER.....	4-40
CHECKING THE REAR BRAKE CALIPER .....	4-40
ASSEMBLING THE REAR BRAKE CALIPER.....	4-41
INSTALLING THE REAR BRAKE CALIPER.....	4-41
REMOVING THE REAR BRAKE MASTER CYLINDER.....	4-42
CHECKING THE REAR BRAKE MASTER CYLINDER .....	4-42
ASSEMBLING THE REAR BRAKE MASTER CYLINDER.....	4-43
INSTALLING THE REAR BRAKE MASTER CYLINDER.....	4-43
<b>HANDLEBARS</b> .....	4-45

REMOVING THE HANDLEBAR .....	4-47
CHECKING THE HANDLEBARS .....	4-47
INSTALLING THE HANDLEBARS.....	4-47
CHECKING THE STEERING DAMPER.....	4-48
<b>FRONT FORK.....</b>	<b>4-50</b>
REMOVING THE FRONT FORK LEGS .....	4-52
DISASSEMBLING THE FRONT FORK LEGS .....	4-52
CHECKING THE FRONT FORK LEGS.....	4-53
ASSEMBLING THE FRONT FORK LEGS .....	4-54
INSTALLING THE FRONT FORK LEGS .....	4-58
<b>STEERING HEAD.....</b>	<b>4-59</b>
REMOVING THE LOWER BRACKET .....	4-61
CHECKING THE STEERING HEAD .....	4-61
INSTALLING THE STEERING HEAD.....	4-61
<b>REAR SHOCK ABSORBER ASSEMBLY .....</b>	<b>4-63</b>
HANDLING THE REAR SHOCK ABSORBER .....	4-64
DISPOSING OF A REAR SHOCK ABSORBER.....	4-64
REMOVING THE REAR SHOCK ABSORBER ASSEMBLY.....	4-64
CHECKING THE REAR SHOCK ABSORBER ASSEMBLY .....	4-64
CHECKING THE CONNECTING ARM AND RELAY ARM .....	4-65
INSTALLING THE RELAY ARM.....	4-65
INSTALLING THE REAR SHOCK ABSORBER ASSEMBLY .....	4-65
<b>SWINGARM .....</b>	<b>4-66</b>
REMOVING THE SWINGARM .....	4-68
CHECKING THE SWINGARM .....	4-69
INSTALLING THE SWINGARM .....	4-69
<b>CHAIN DRIVE .....</b>	<b>4-71</b>
REMOVING THE DRIVE CHAIN .....	4-72
CHECKING THE DRIVE CHAIN .....	4-72
CHECKING THE REAR WHEEL SPROCKET .....	4-73
CHECKING THE REAR WHEEL DRIVE HUB .....	4-73
INSTALLING THE DRIVE CHAIN.....	4-73



# GENERAL CHASSIS

EAS21830

## GENERAL CHASSIS

### Removing the seat and battery

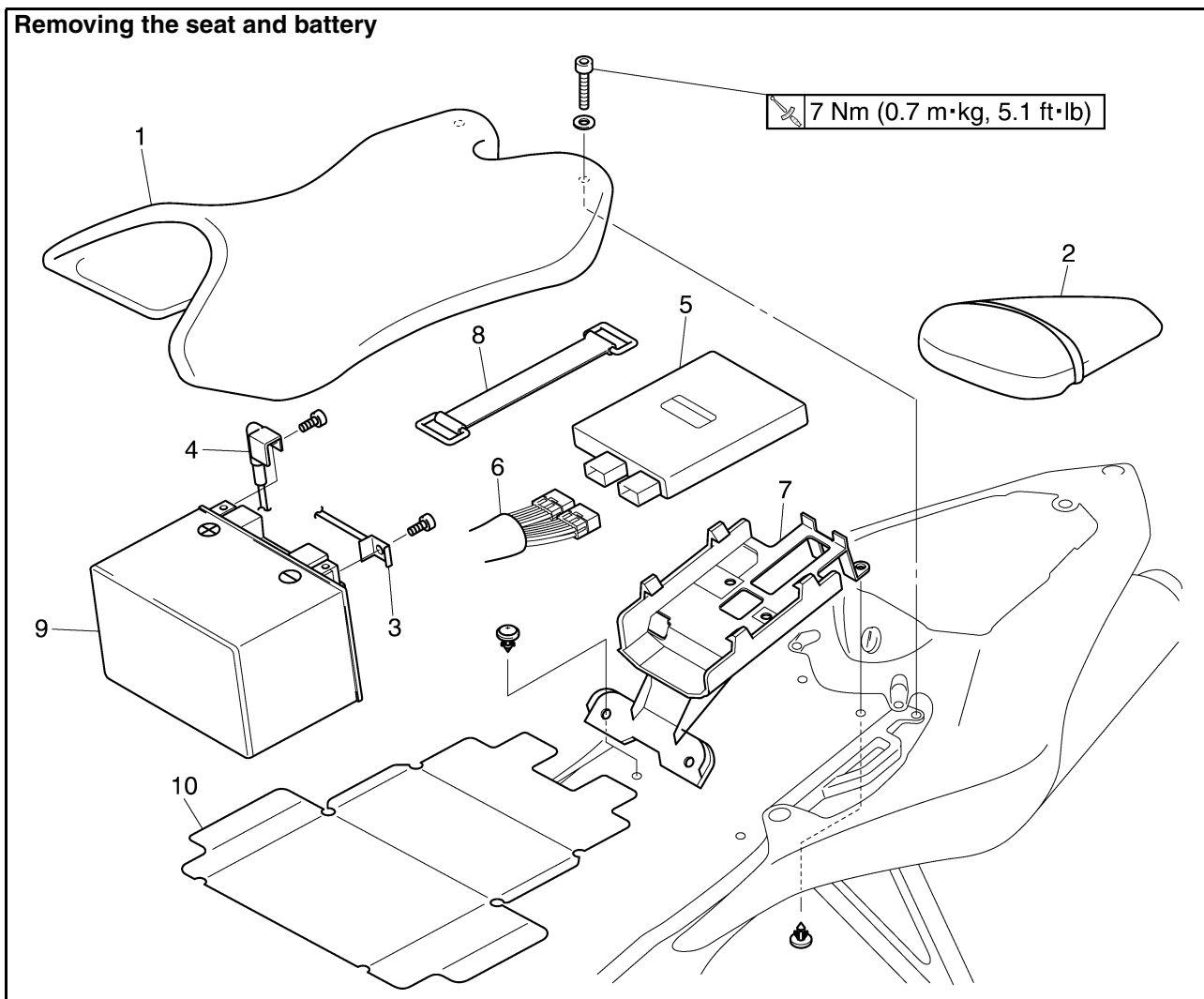

Order	Job/Parts to remove	Q'ty	Remarks
1	Rider seat		
2	Passenger seat	1	
3	Battery negative lead	1	
4	Battery positive lead	1	
5	ECU (engine control unit)	1	
6	ECU lead coupler	1	Disconnect.
7	ECU cover	1	
8	Battery band	1	
9	Battery	1	
10	Battery seat	1	
			For installation, reverse the removal procedure.

## GENERAL CHASSIS

### Removing the front cowling and side cowlings

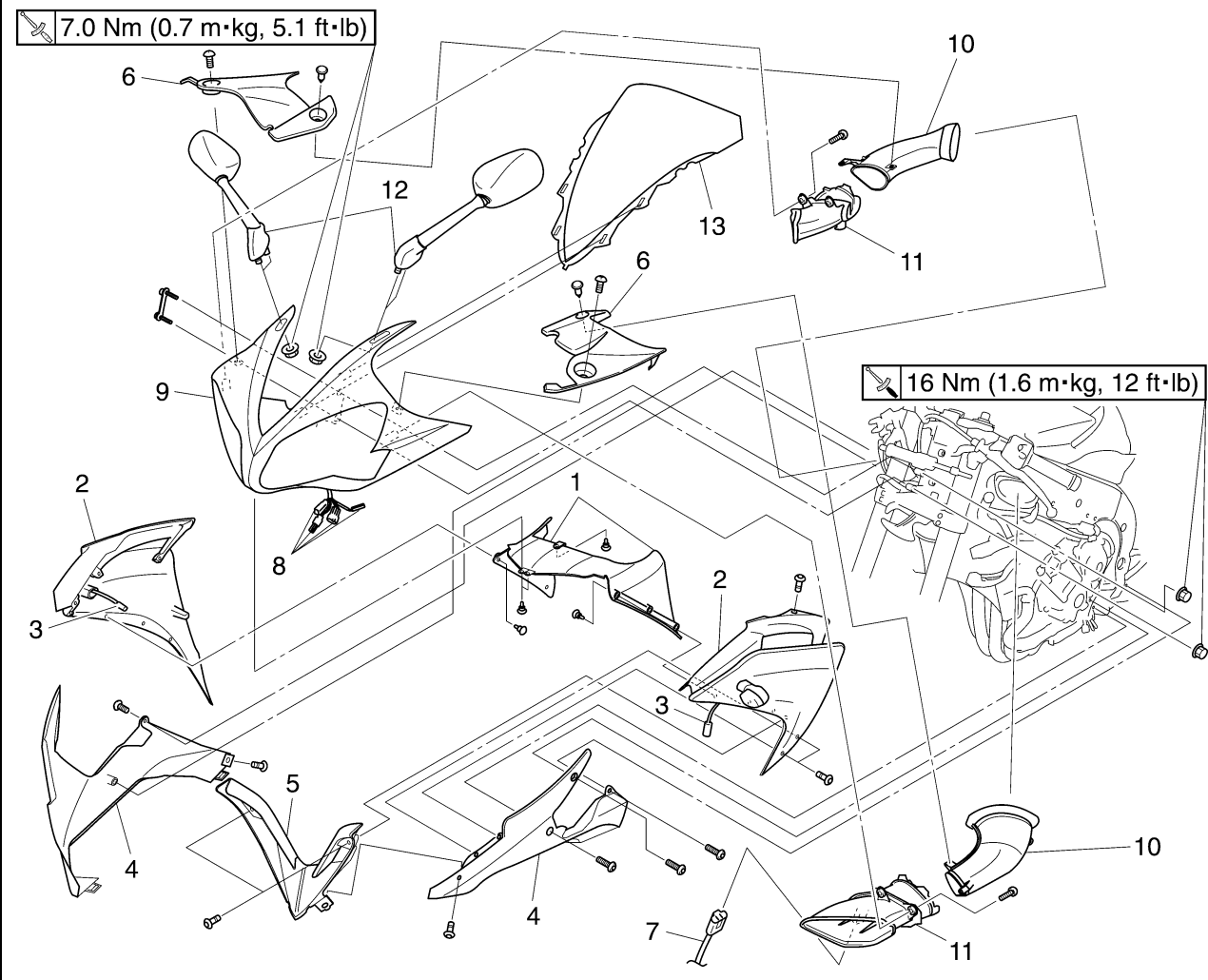

Order	Job/Parts to remove	Q'ty	Remarks
1	Side cowling inner panel	2	
2	Side cowling	2	
3	Front turn signal light lead coupler	2	Disconnect.
4	Lower cowling	2	
5	Lower cowling front cover	1	
6	Intake air duct panel	2	
7	Intake air temperature coupler	1	Disconnect.
8	Meter assembly coupler	1	Disconnect.
9	Front cowling	1	
10	Rear intake air duct	2	
11	Front intake air duct	2	
12	Rear view mirror	2	
13	Windshield	1	
			For installation, reverse the removal procedure.

## GENERAL CHASSIS

### Removing the rear fender

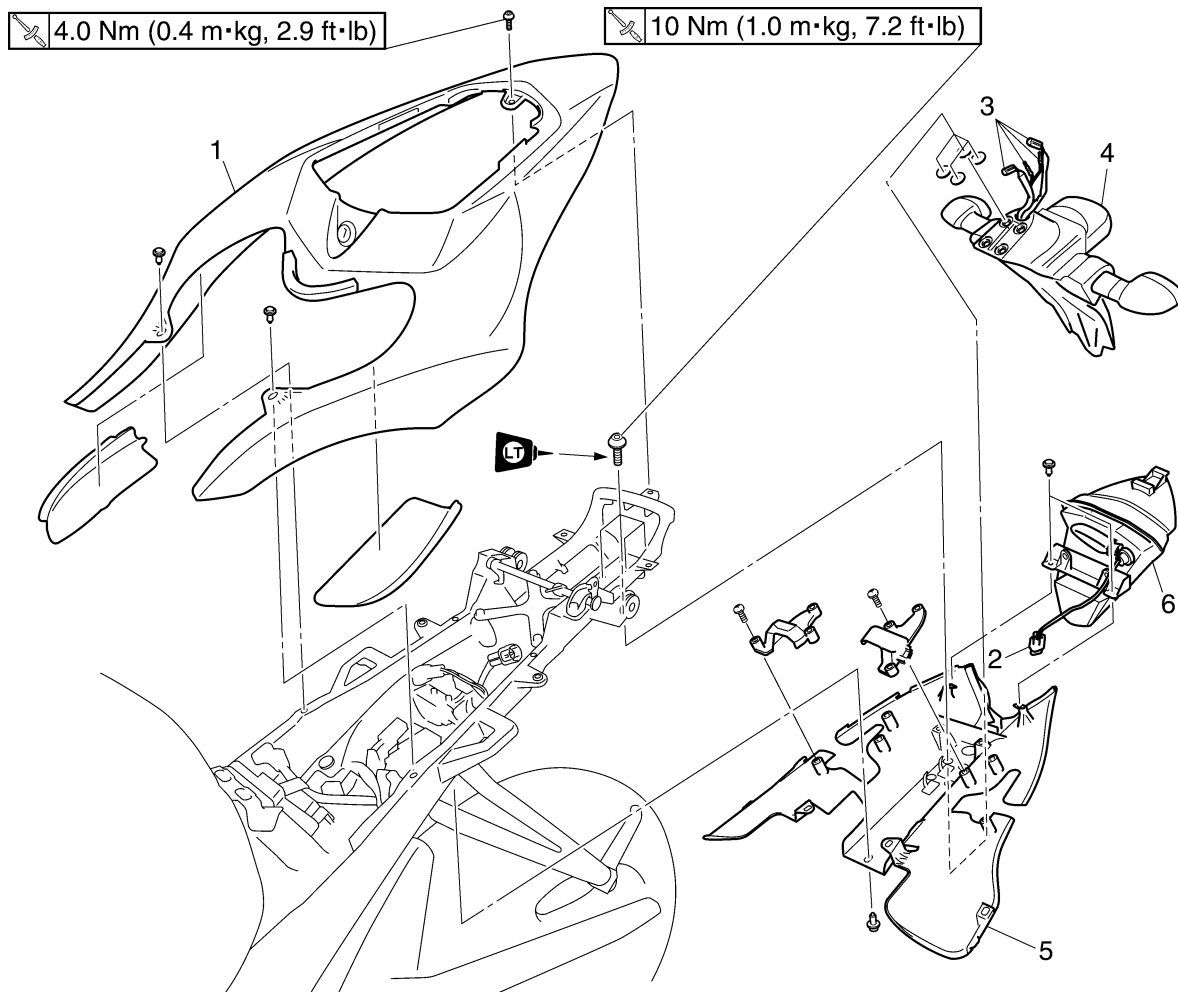

Order	Job/Parts to remove	Q'ty	Remarks
	Rider seat		Refer to "GENERAL CHASSIS" on page 4-1.
	Passenger seat		Refer to "GENERAL CHASSIS" on page 4-1.
	Muffler		Refer to "ENGINE REMOVAL" on page 5-1.
1	Upper tail cover	1	
2	Tail/brake light lead coupler	1	Disconnect.
3	Turn signal light/licence plate light lead coupler	4	Disconnect.
4	Mud guard assembly	1	
5	Lower tail cover	1	
6	Tail/brake light	1	
			For installation, reverse the removal procedure.

## GENERAL CHASSIS

### Removing the air filter case

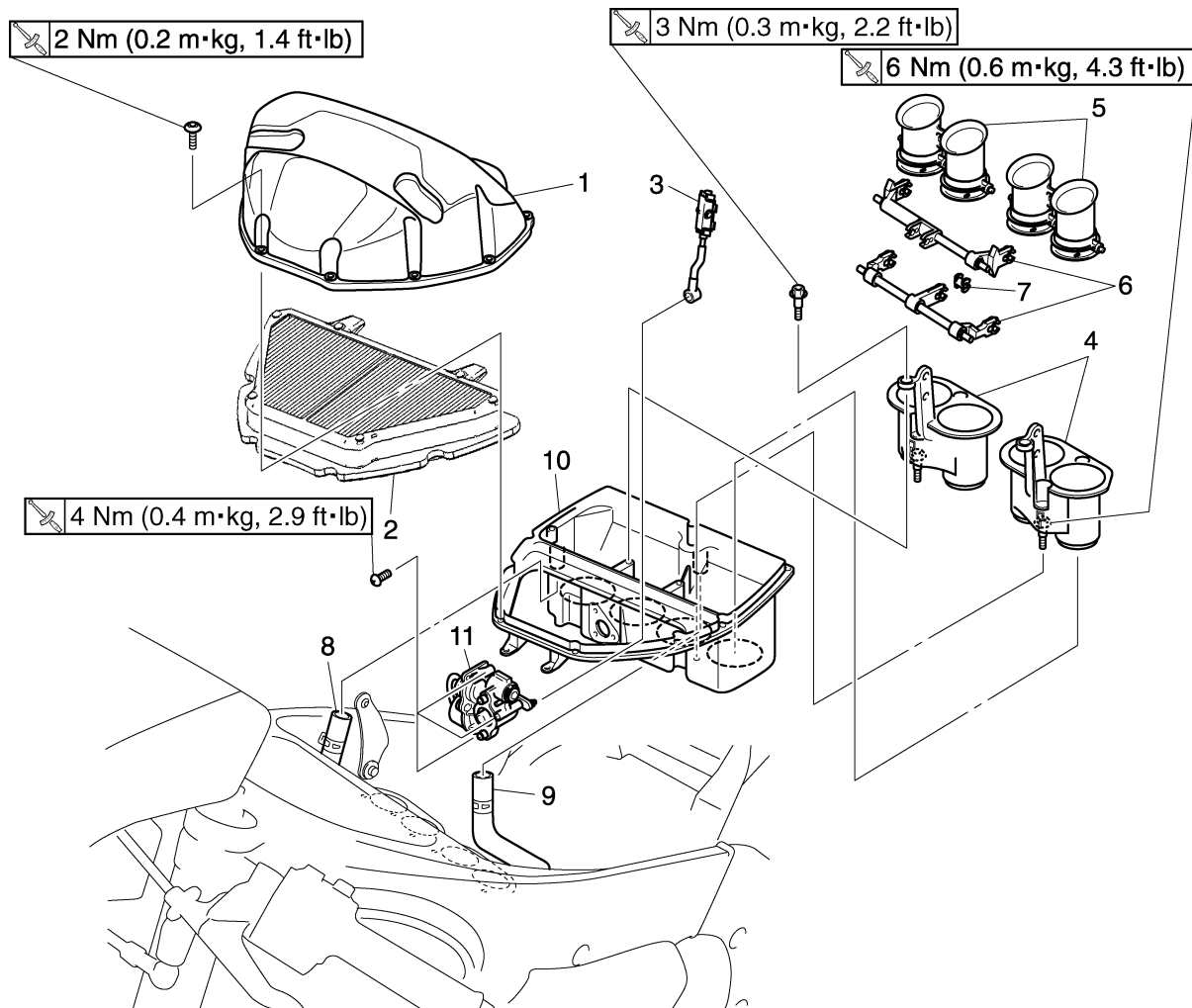

Order	Job/Parts to remove	Q'ty	Remarks
	Rider seat		Refer to "GENERAL CHASSIS" on page 4-1.
	Fuel tank		Refer to "FUEL TANK" on page 7-1.
1	Air filter case cover	1	
2	Air filter	1	
3	Intake funnel servo motor rod assembly	1	
4	Intake funnel joint	2	
5	Intake funnel	2	
6	Intake funnel rod	2	
7	Bushing 2	5	
8	Air induction system hose	1	
9	Crankcase breather hose	1	
10	Air filter case	1	
11	Intake funnel servo motor	1	
			For installation, reverse the removal procedure.

## GENERAL CHASSIS

EAS4C81025

### CHECKING THE INTAKE FUNNEL

1. Check:

- Intake funnel  
Cracks/damage → Replace.
- Intake funnel seal rubber "1"  
Cracks/damage → Replace.

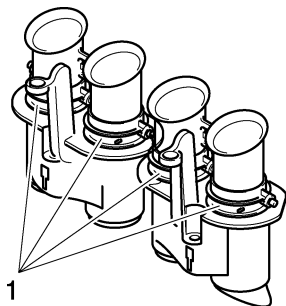

- Intake funnel rods  
Damage/scratches → Replace.

EAS4C81026

### ASSEMBLING THE INTAKE FUNNEL

1. Install:

- Intake funnel rod
- Intake funnel

#### NOTE:

- To install the intake funnel, do not mistake the front and rear directions.
- For Bushing 2 "a", point the direction of notch hole as shown in the illustration.

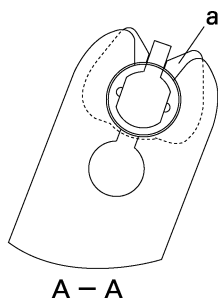
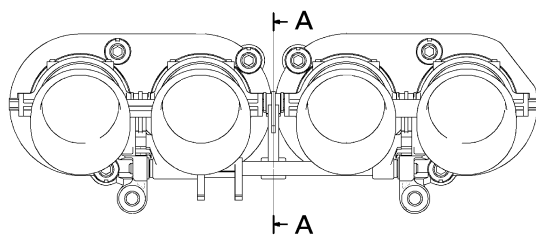

ECA4C81020

#### CAUTION:

- After assembly, make sure that the intake funnel smoothly moves to the contacting

surface between upper stopper and lower seating position when it is moved by hand.

- Make sure that the intake funnel smoothly strokes from the upper position to the seating position by its own weight.

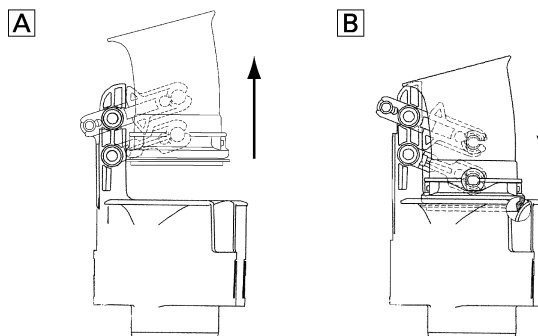

A. Upper

B. Lower

- Air filter case
- Intake funnel joint bolt "1"



**Intake funnel joint bolt**  
6 Nm (0.6 m·kg, 4.3 ft·lb)

ECA4C81022

#### CAUTION:

Do not remove the bolts from the intake funnel joint.

- Intake funnel joint bolt "2"

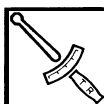

**Intake funnel joint bolt**  
3 Nm (0.3 m·kg, 2.2 ft·lb)

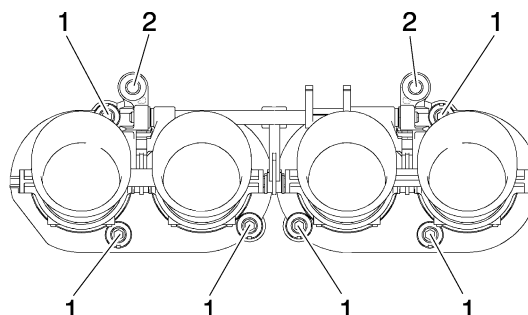

- Intake funnel servo motor rod assembly

EAS4C81027

### CHECKING THE INTAKE FUNNEL OPERATION

1. Check:

- Intake funnel operation

## GENERAL CHASSIS

---



- a. Activate the diagnostic mode and select the diagnostic code number "34".  
Refer to "FUEL INJECTION SYSTEM" on page 8-29.
- b. Set the engine stop switch to "○".
- c. Check that the intake funnel operate smoothly strokes from the upper position to the lower seating position.



## GENERAL CHASSIS

EAS21840

### REMOVING THE COVER

1. Remove:
  - Tail cover
  - Rear fender

**NOTE:**

To remove the quick fastener, push its center with a screwdriver, then pull the fastener out.

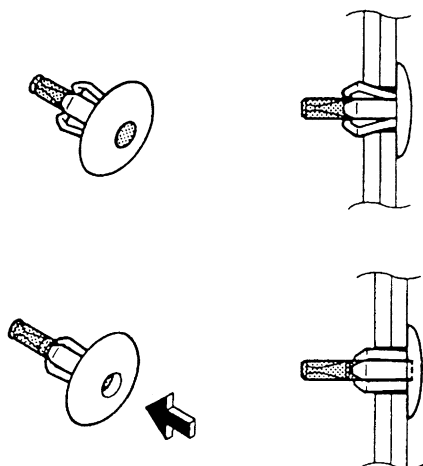

EAS21850

### INSTALLING THE COVER

1. Install:
  - Rear fender
  - Tail cover

**NOTE:**

To install the quick fastener, push its pin so that it protrudes from the fastener head, then insert the fastener into the cover and push the pin "a" in with screwdriver. Make sure that the pin is flush with the fastener's head.

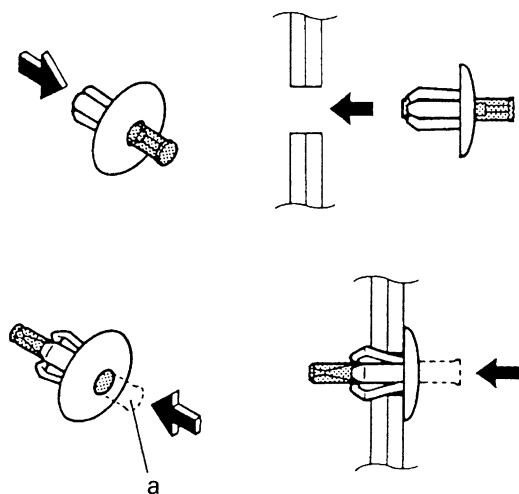

# FRONT WHEEL

EAS21870

## FRONT WHEEL

### Removing the front wheel and brake discs

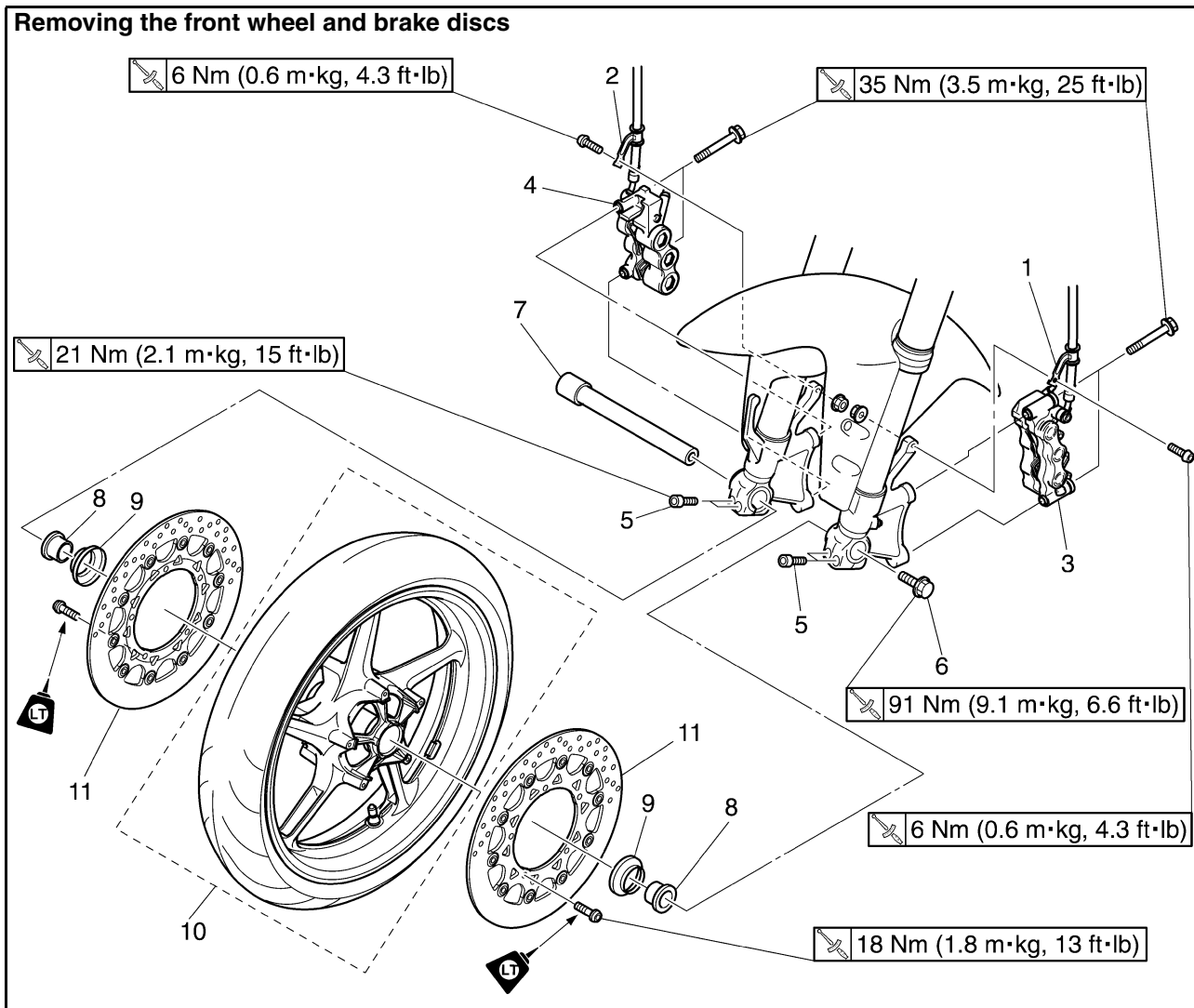

Order	Job/Parts to remove	Q'ty	Remarks
1	Left brake hose holder	1	
2	Right brake hose holder	1	
3	Left front brake caliper	1	
4	Right front brake caliper	1	
5	Front wheel axle pinch bolt	4	
6	Front wheel axle bolt	1	
7	Front wheel axle	1	
8	Collar (left and right)	2	
9	Dust cover (left and right)	2	
10	Front wheel	1	
11	Front brake disc (left and right)	2	
			For installation, reverse the removal procedure.

## FRONT WHEEL

**Disassembling the front wheel**

Order	Job/Parts to remove	Q'ty	Remarks
1	Oil seal (left and right)	2	
2	Wheel bearing (left and right)	1	
3	Spacer	1	
			For assembly, reverse the disassembly procedure.



## FRONT WHEEL

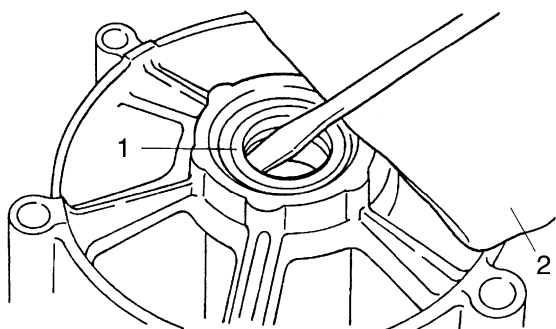

c. Remove the wheel bearings "3" with a general bearing puller.

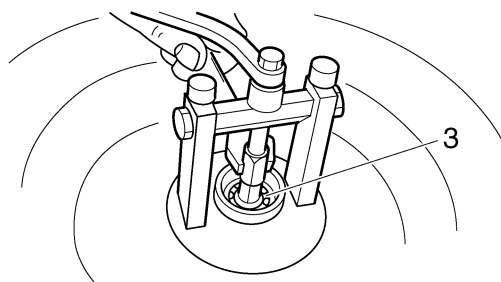

d. Install the new wheel bearings and oil seals in the reverse order of disassembly.

ECA14130

**CAUTION:**

**Do not contact the wheel bearing inner race "4" or balls "5". Contact should be made only with the outer race "6".**

**NOTE:**

Use a socket "7" that matches the diameter of the wheel bearing outer race and oil seal.

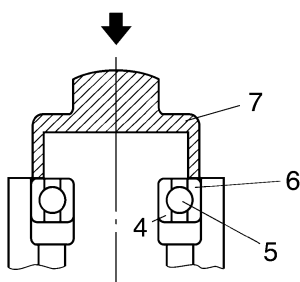

EAS21970

### ADJUSTING THE FRONT WHEEL STATIC BALANCE

**NOTE:**

- After replacing the tire, wheel or both, the front wheel static balance should be adjusted.

- Adjust the front wheel static balance with the brake disc installed.

1. Remove:
  - Balancing weight(s)
2. Find:
  - Front wheel's heavy spot

**NOTE:**

Place the front wheel on a suitable balancing stand.



- a. Spin the front wheel.
- b. When the front wheel stops, put an "X<sub>1</sub>" mark at the bottom of the wheel.

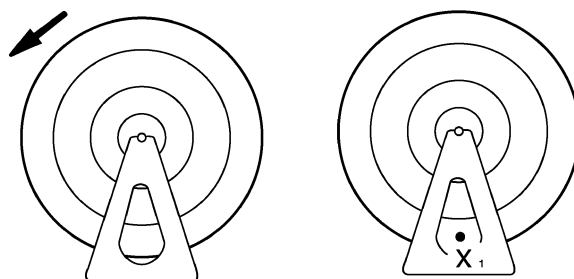

- c. Turn the front wheel 90° so that the "X<sub>1</sub>" mark is positioned as shown.
- d. Release the front wheel.
- e. When the wheel stops, put an "X<sub>2</sub>" mark at the bottom of the wheel.

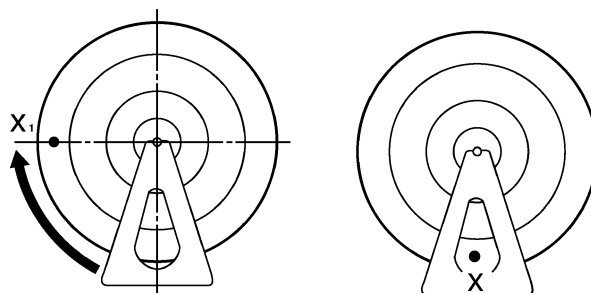

- f. Repeat steps (d) through (f) several times until all the marks come to rest at the same spot.
- g. The spot where all the marks come to rest is the front wheel's heavy spot "X".



3. Adjust:
  - Front wheel static balance



- a. Install a balancing weight "1" onto the rim exactly opposite the heavy spot "X".

# FRONT WHEEL

**NOTE:** \_\_\_\_\_  
 Start with the lightest weight.

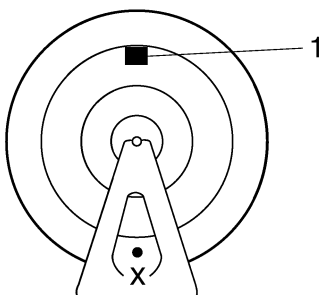

b. Turn the front wheel 90° so that the heavy spot is positioned as shown.

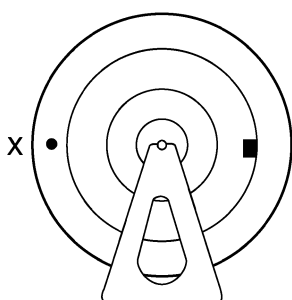

c. If the heavy spot does not stay in that position, install a heavier weight.  
 d. Repeat steps (b) and (c) until the front wheel is balanced.



4. Check:  
 • Front wheel static balance



a. Turn the front wheel and make sure it stays at each position shown.

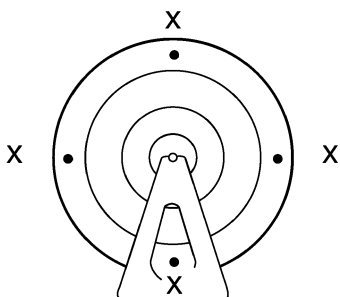

b. If the front wheel does not remain stationary at all of the positions, rebalance it.



EAS22000  
**INSTALLING THE FRONT WHEEL**

The following procedure applies to both of the brake discs.

1. Lubricate:
  - Wheel axle
  - Oil seal lips

	<b>Recommended lubricant</b> <b>Lithium-soap-based grease</b>
--	--

2. Lift the wheel up between the fork legs.
3. Insert the wheel axle.

**NOTE:** \_\_\_\_\_  
 Install the tire and wheel with the mark "1" pointing in the direction of wheel rotation.

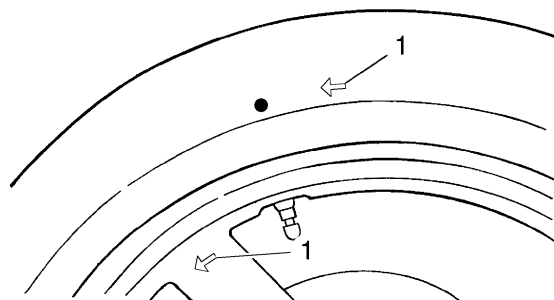

4. Lower the front wheel so that it is on the ground.
5. Tighten:
  - Front wheel axle bolt

	<b>Front wheel axle bolt</b> <b>91 Nm (9.1 m·kg, 66 ft·lb)</b>
--	---

- Front wheel axle pinch bolt

	<b>Front wheel axle pinch bolt</b> <b>21 Nm (2.1 m·kg, 15 ft·lb)</b>
--	---

ECA4C81001

**CAUTION:** \_\_\_\_\_

**Before tightening the wheel axle, push down hard on the handlebar(s) several times and check if the front fork rebounds smoothly.**

6. Install:
  - Front brake calipers

	<b>Front brake caliper bolt</b> <b>35 Nm (3.5 m·kg, 25 ft·lb)</b>
--	--

EWA13490

**WARNING**

**Make sure the brake cable is routed properly.**

## FRONT WHEEL

---

**NOTE:**

Make sure that there is enough space between the brake pads before installing the brake calipers on to the brake discs.

---

# REAR WHEEL

EAS22020

## REAR WHEEL

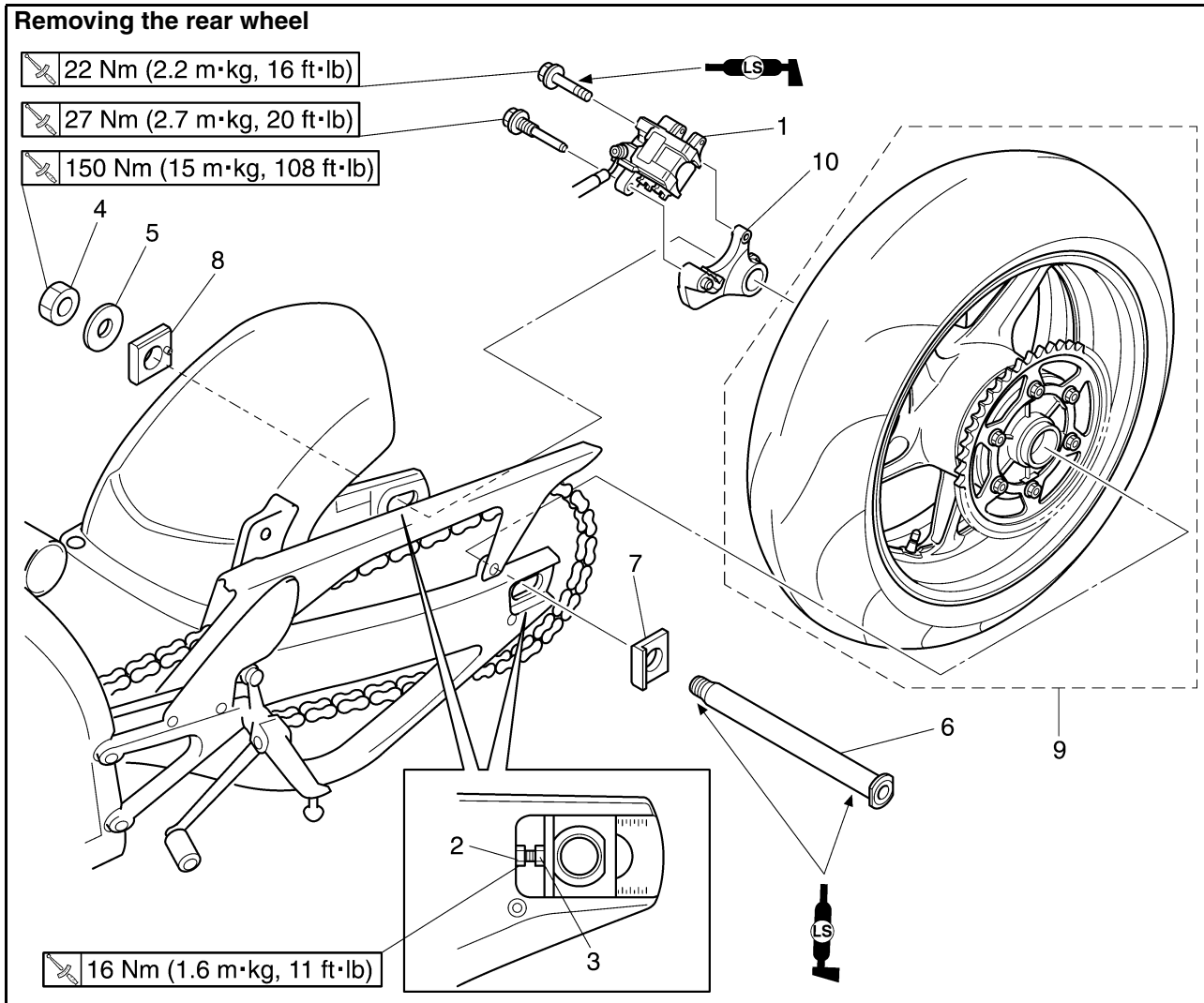

Order	Job/Parts to remove	Q'ty	Remarks
1	Rear brake caliper	1	
2	Locknut (left and right)	2	Loosen.
3	Adjusting bolt (left and right)	2	Loosen.
4	Rear wheel axle nut	1	
5	Washer	1	
6	Rear wheel axle	1	
7	Left adjusting block	1	
8	Right adjusting block	1	
9	Rear wheel	1	
10	Rear brake caliper bracket	1	
			For installation, reverse the removal procedure.

## REAR WHEEL

### Removing the brake disc and rear wheel sprocket

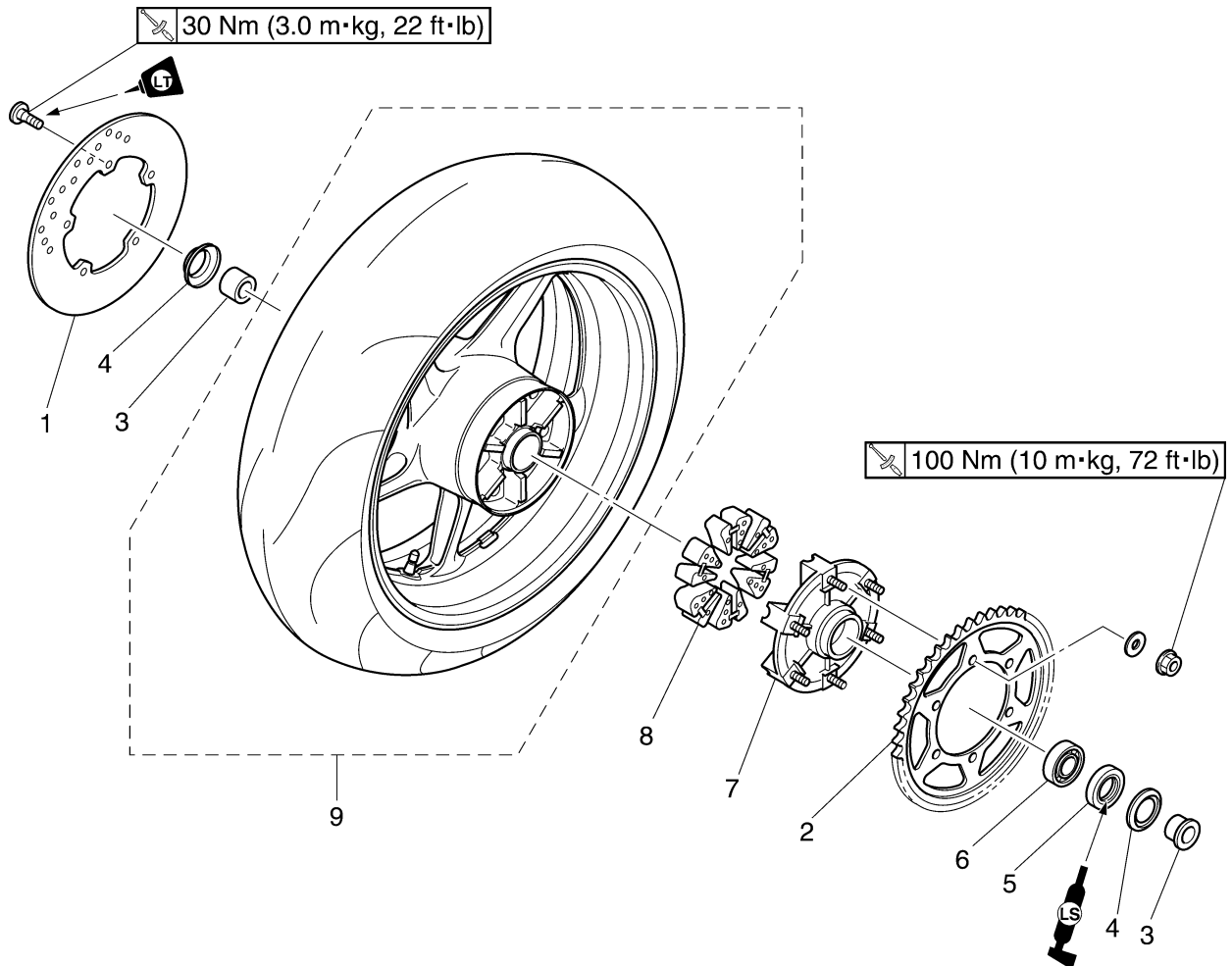

Order	Job/Parts to remove	Q'ty	Remarks
1	Rear brake disc	1	
2	Rear wheel sprocket	1	
3	Collar	2	
4	Dust cover	2	
5	Oil seal	1	
6	Bearing	1	
7	Rear wheel drive hub	1	
8	Rear wheel drive hub damper	6	
9	Rear wheel	1	
			For installation, reverse the removal procedure.

## REAR WHEEL

### Disassembling the rear wheel

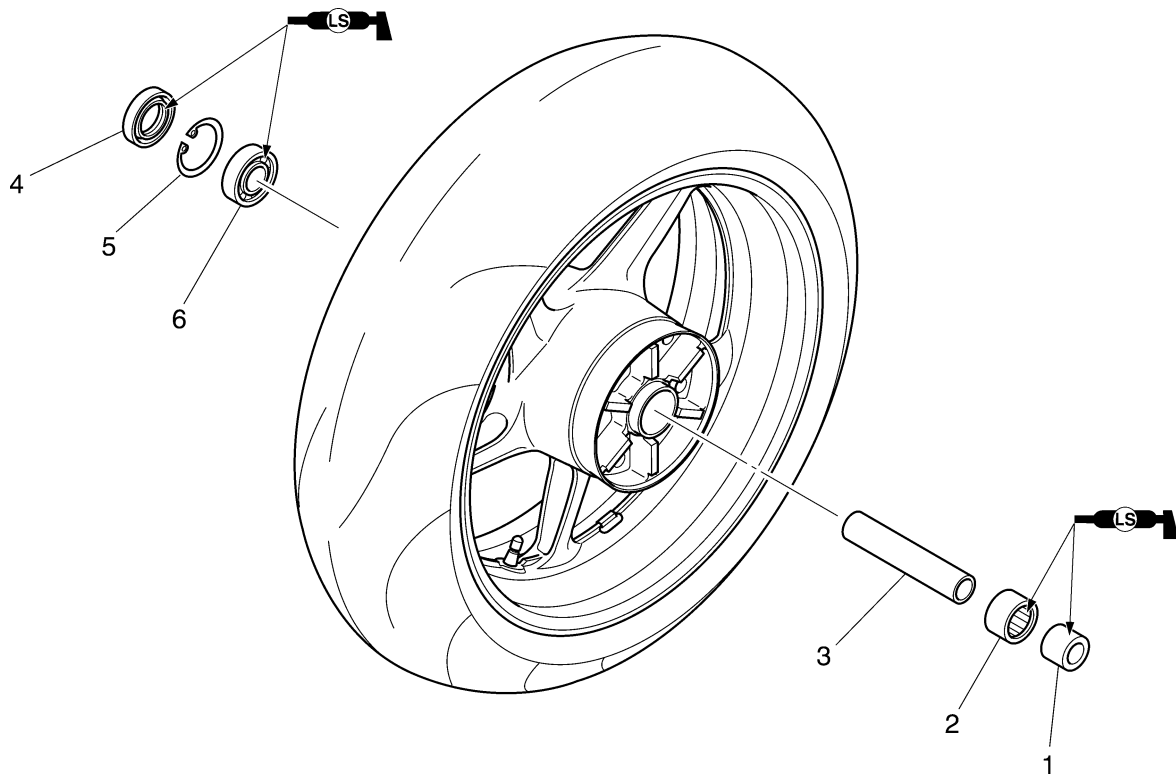

Order	Job/Parts to remove	Q'ty	Remarks
1	Collar	1	
2	Bearing	1	
3	Spacer	1	
4	Oil seal	1	
5	Circlip	1	
6	Bearing	1	
			For assembly, reverse the disassembly procedure.

## REAR WHEEL

EAS22040

### REMOVING THE REAR WHEEL

1. Stand the vehicle on a level surface.

EWA13120

#### WARNING

Securely support the vehicle so that there is no danger of it falling over.

#### NOTE:

Place the vehicle on a suitable stand so that the rear wheel is elevated.

2. Remove:

- Brake caliper "1"

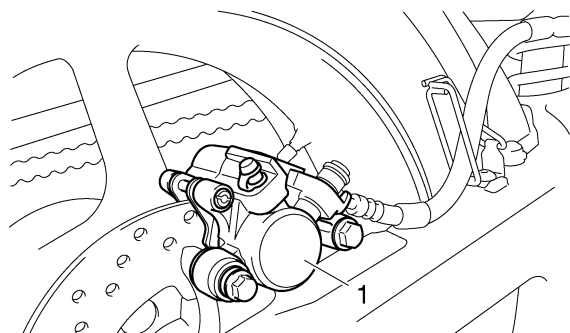

#### NOTE:

Do not depress the brake pedal when removing the brake caliper.

3. Loosen:

- Locknut "1"
- Adjusting nut "2"

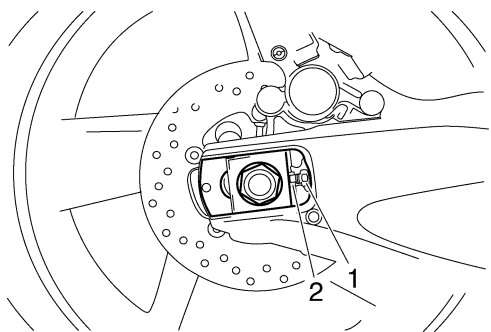

4. Remove:

- Wheel axle nut "1"
- Wheel axle
- Rear wheel

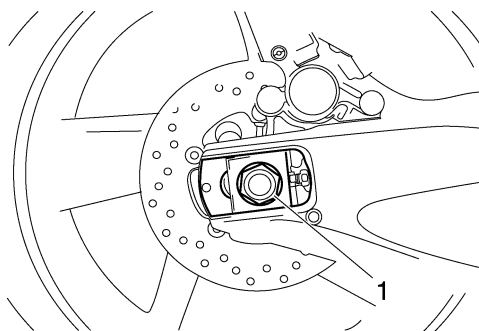

#### NOTE:

Push the rear wheel forward and remove the drive chain from the rear wheel sprocket.

5. Remove:

- Left collar "1"
- Rear wheel drive hub "2"
- Rear wheel drive hub damper
- Right collar

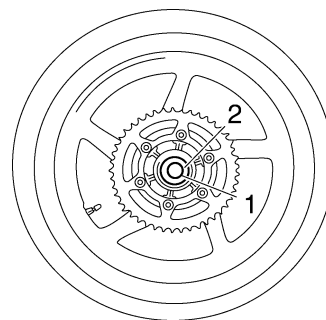

EAS22090

### CHECKING THE REAR WHEEL

1. Check:

- Wheel axle
- Rear wheel
- Wheel bearings
- Oil seals

Refer to "CHECKING THE FRONT WHEEL" on page 4-10.

2. Check:

- Tire
- Rear wheel

Damage/wear → Replace.

Refer to "CHECKING THE TIRES" on page 3-33 and "CHECKING THE WHEELS" on page 3-35.

3. Measure:

- Radial wheel runout
- Lateral wheel runout

Refer to "CHECKING THE FRONT WHEEL" on page 4-10.

## REAR WHEEL

EAS22110

### CHECKING THE REAR WHEEL DRIVE HUB

- Check:
  - Rear wheel drive hub "1"  
Cracks/damage → Replace.
  - Rear wheel drive hub dampers "2"  
Damage/wear → Replace.

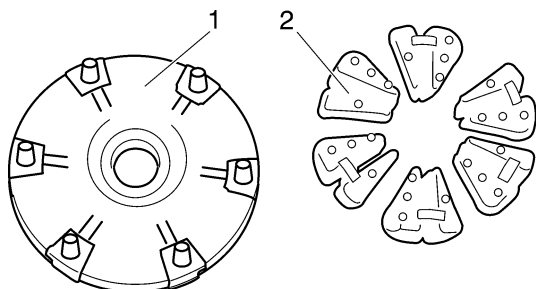

### NOTE:

Tighten the self-locking nuts in stages and in a crisscross pattern.

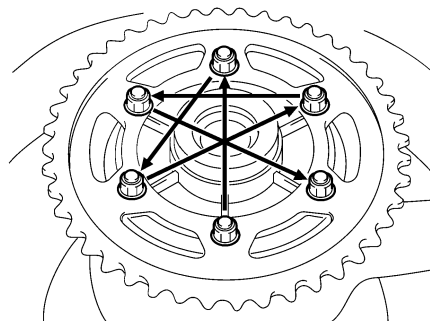

EAS22120

### CHECKING AND REPLACING THE REAR WHEEL SPROCKET

- Check:
  - Rear wheel sprocket  
More than 1/4 tooth "a" wear → Replace the rear wheel sprocket.  
Bent teeth → Replace the rear wheel sprocket.

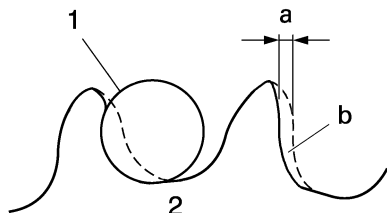

b. Correct

- Drive chain roller
- Rear wheel sprocket

- Replace:
  - Rear wheel sprocket

- Remove the self-locking nuts and the rear wheel sprocket.
- Clean the rear wheel drive hub with a clean cloth, especially the surfaces that contact the sprocket.
- Install the new rear wheel sprocket.

	<p><b>Rear wheel sprocket self-locking nut</b> 100 Nm (10 m·kg, 72 ft·lb)</p>
---	---

EAS22150

### ADJUSTING THE REAR WHEEL STATIC BALANCE

### NOTE:

- After replacing the tire, wheel or both, the rear wheel static balance should be adjusted.
- Adjust the rear wheel static balance with the brake disc and rear wheel drive hub installed.

- Adjust:

- Rear wheel static balance  
Refer to "ADJUSTING THE FRONT WHEEL STATIC BALANCE" on page 4-11.

EAS22160

### INSTALLING THE REAR WHEEL

- Lubricate:
  - Wheel axle
  - Wheel bearings
  - Oil seal lips

	<p><b>Recommended lubricant</b> Lithium-soap-based grease</p>
---	---

- Adjust:

- Drive chain slack  
Refer to "ADJUSTING THE DRIVE CHAIN SLACK" on page 3-27.

	<p><b>Drive chain slack</b> 30.0–40.0 mm (1.18–1.57 in)</p>
---	---

- Tighten:

- Rear wheel axle nut
- Rear brake caliper bolts

## REAR WHEEL

---



Rear wheel axle nut  
150 Nm (15.0 m·kg, 108 ft·lb)  
Rear brake caliper bolt (front  
side)  
27 Nm (2.7 m·kg, 20 ft·lb)  
Rear brake caliper bolt (rear  
side)  
22 Nm (2.2 m·kg, 16 ft·lb)

EWA13500



**Make sure the brake hose is routed properly.**

---

# FRONT BRAKE

EAS22210

## FRONT BRAKE

### Removing the front brake pads

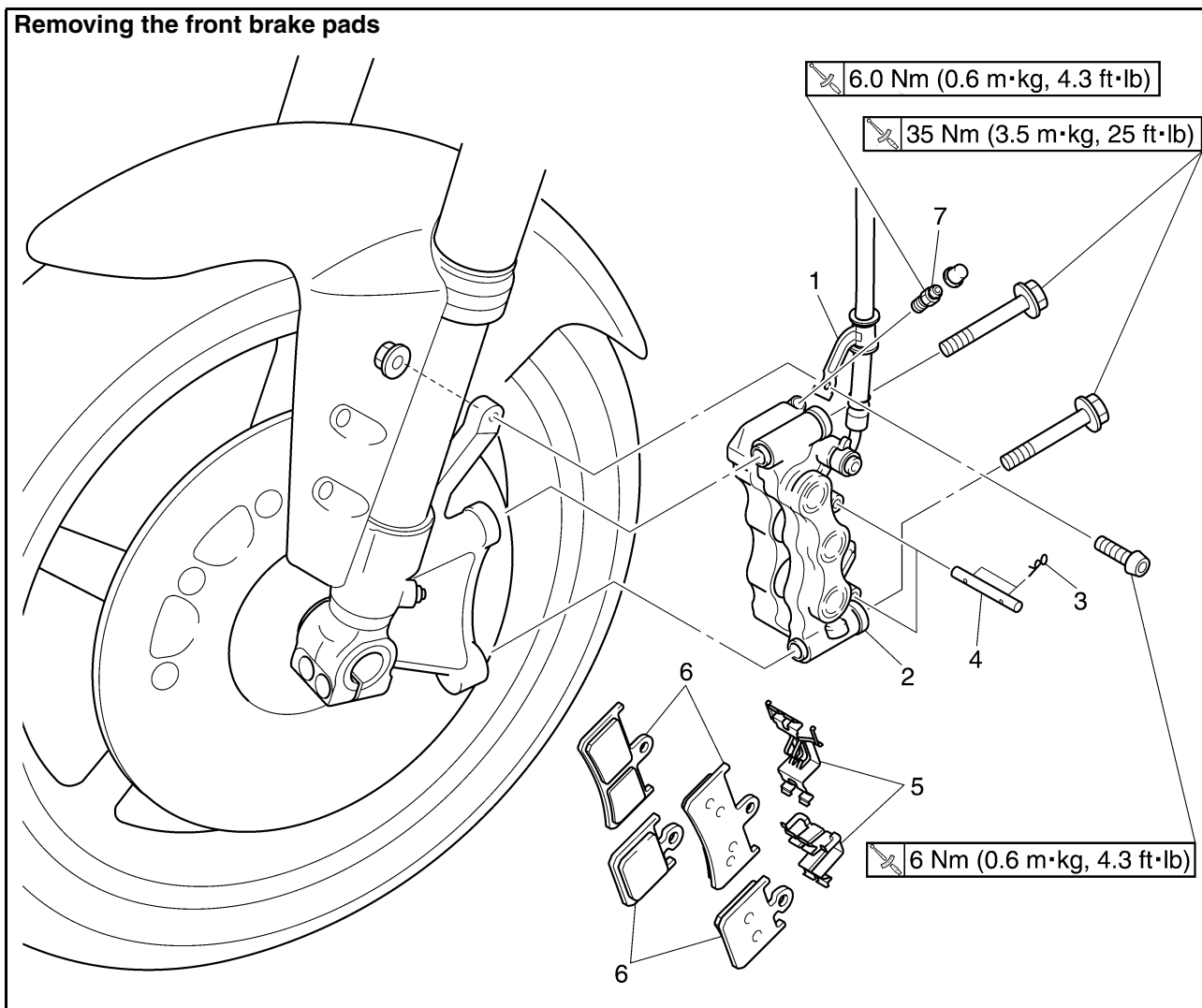

Order	Job/Parts to remove	Q'ty	Remarks
1	Brake hose holder	1	
2	Front brake caliper	1	
3	Brake pad clip	4	
4	Brake pad pin	2	
5	Brake pad spring	2	
6	Brake pad	4	
7	Bleed screw	1	
			For installation, reverse the removal procedure.

## FRONT BRAKE

### Removing the front brake master cylinder

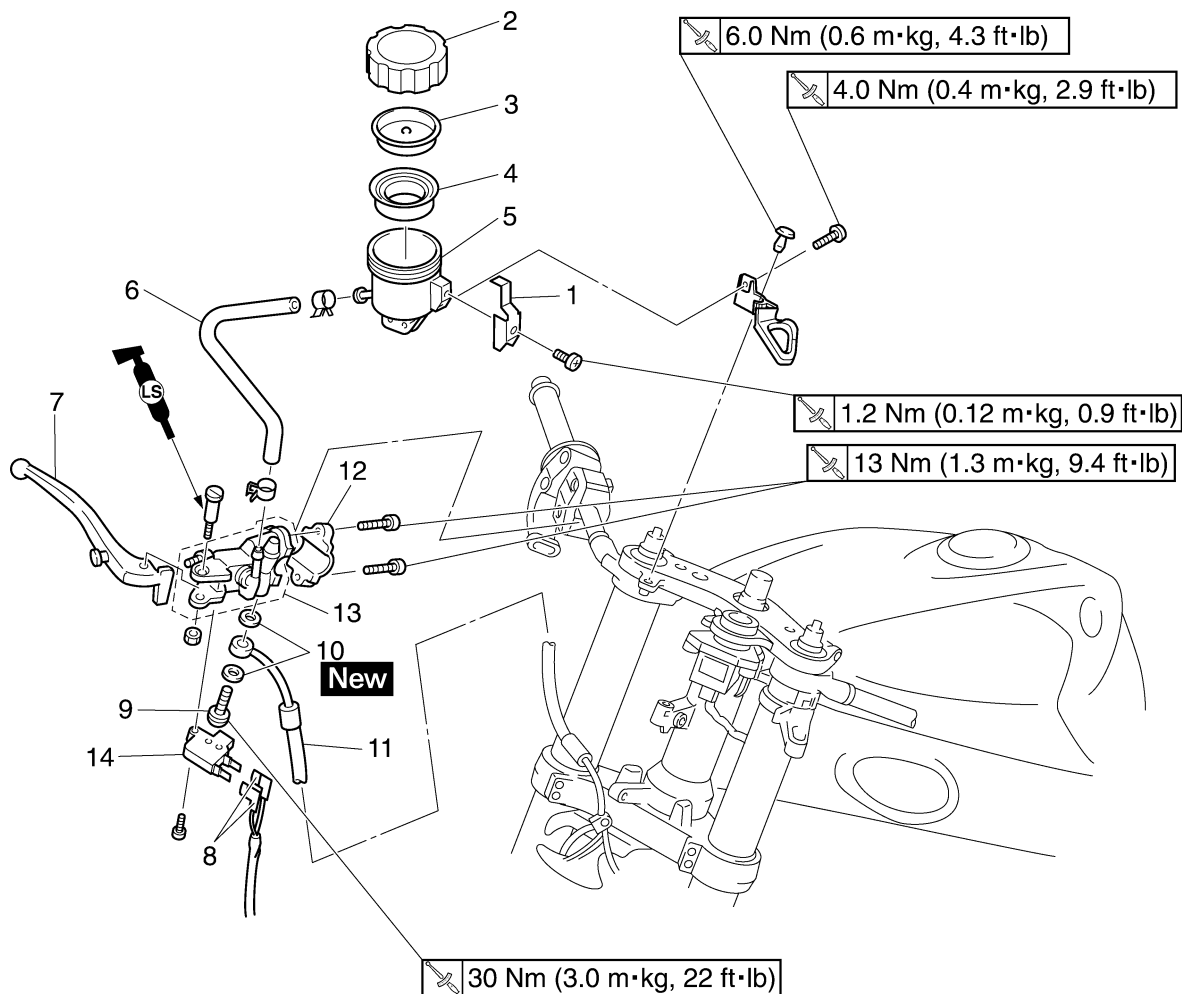

Order	Job/Parts to remove	Q'ty	Remarks
	Brake fluid		Drain. Refer to "BLEEDING THE HYDRAULIC BRAKE SYSTEM" on page 3-26.
1	Stopper	1	
2	Brake fluid reservoir cap	1	
3	Brake fluid reservoir diaphragm holder	1	
4	Brake fluid reservoir diaphragm	1	
5	Brake fluid reservoir tank	1	
6	Brake fluid reservoir hose	1	
7	Brake lever	1	
8	Front brake light switch lead connector	1	Disconnect.
9	Union bolt	1	
10	Copper washer	2	
11	Brake hose	1	
12	Brake master cylinder holder	1	
13	Brake master cylinder	1	
14	Front brake light switch	1	
			For installation, reverse the removal procedure.

## FRONT BRAKE

### Disassembling the front brake master cylinder

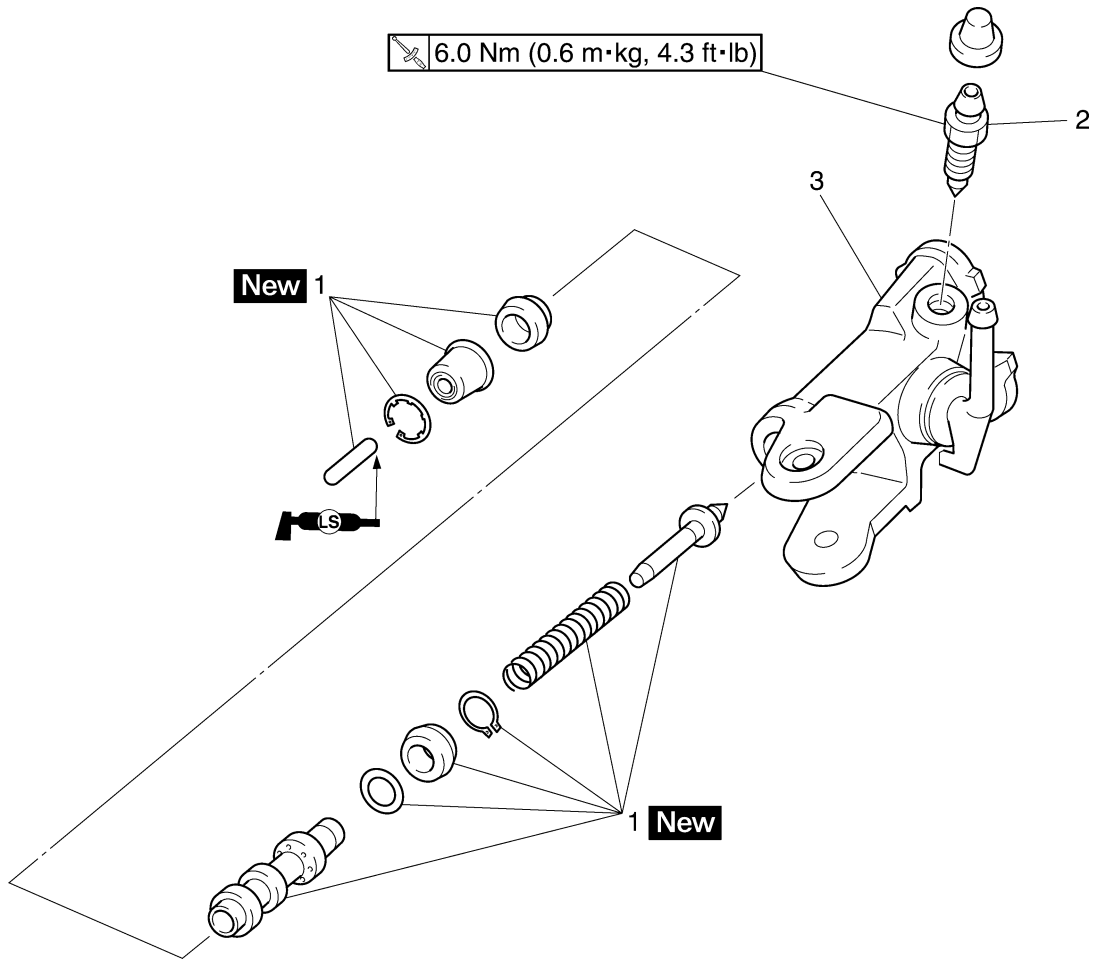

Order	Job/Parts to remove	Q'ty	Remarks
1	Brake master cylinder kit	1	
2	Bleed screw	1	
3	Brake master cylinder body	1	
			For assembly, reverse the disassembly procedure.

## FRONT BRAKE

### Removing the front brake calipers

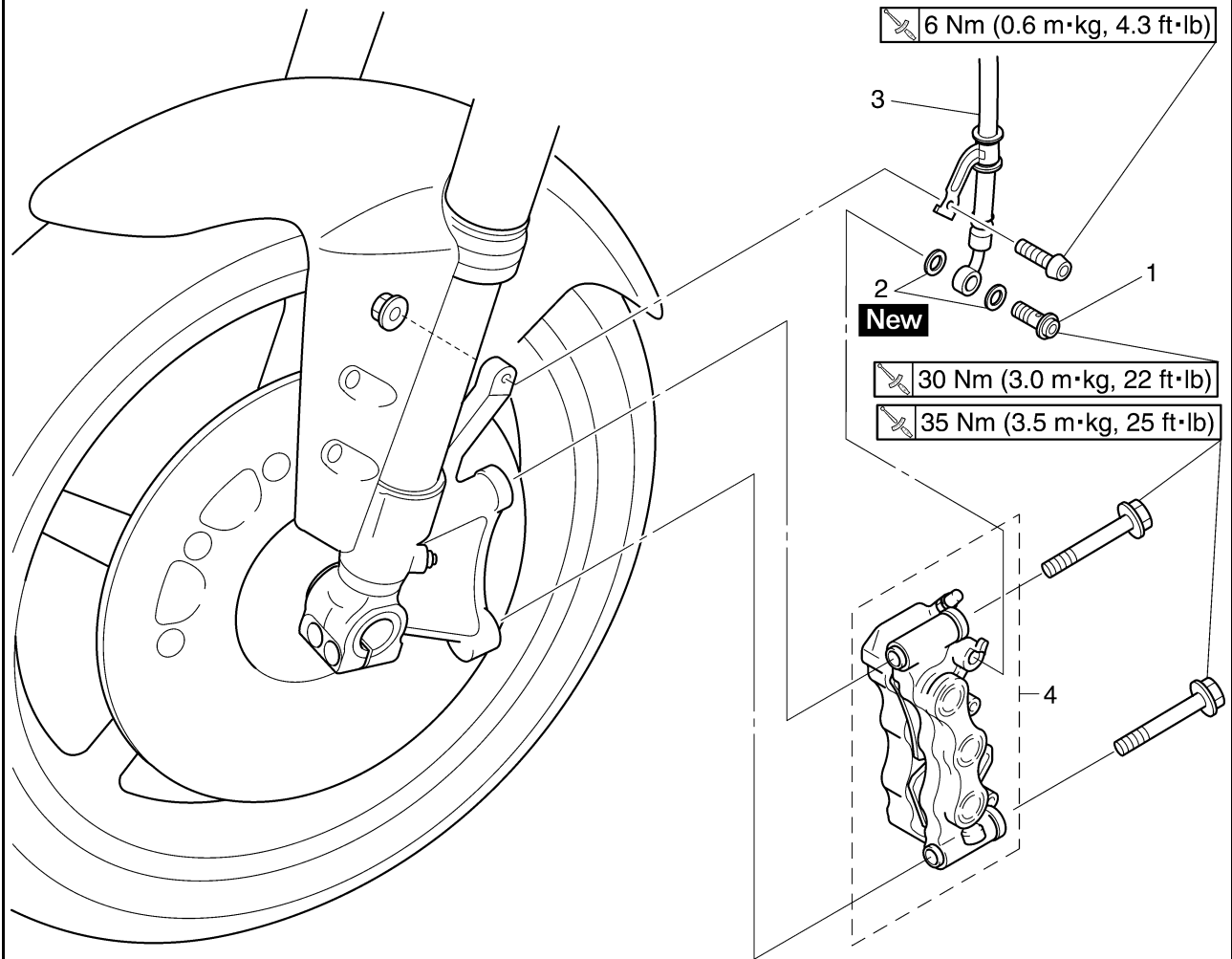

Order	Job/Parts to remove	Q'ty	Remarks
	Brake fluid		Drain. Refer to "BLEEDING THE HYDRAULIC BRAKE SYSTEM" on page 3-26.
1	Union bolt	1	
2	Copper washer	2	
3	Brake hose	1	
4	Brake caliper	1	
			For installation, reverse the removal procedure.

## FRONT BRAKE

### Disassembling the front brake calipers

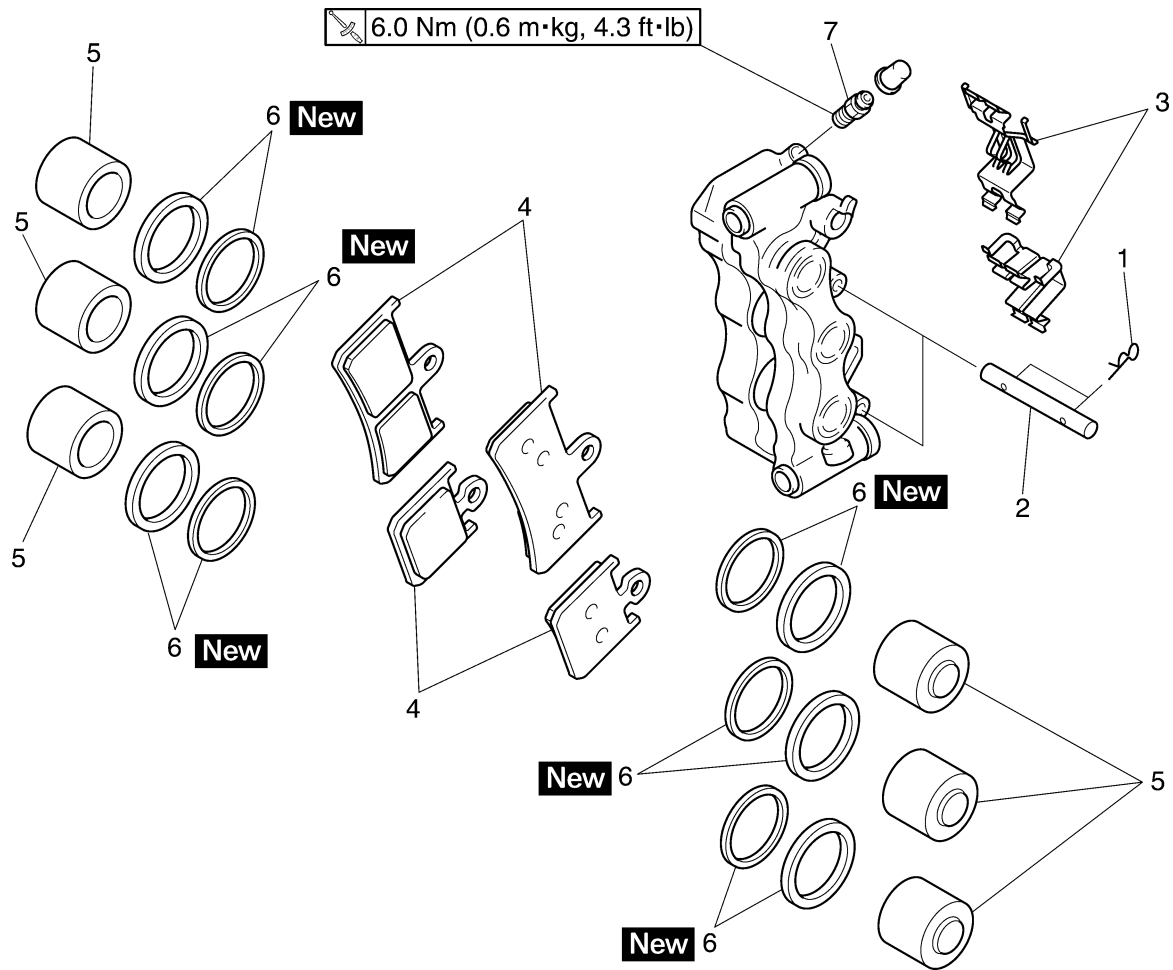

Order	Job/Parts to remove	Q'ty	Remarks
1	Brake pad clip	4	
2	Brake pad pin	2	
3	Brake pad spring	2	
4	Brake pad	4	
5	Brake caliper piston	6	
6	Brake caliper piston seal	12	
7	Bleed screw	1	
			For assembly, reverse the disassembly procedure.

## FRONT BRAKE

EAS22220

### INTRODUCTION

EWA14100

#### ⚠ WARNING

Disc brake components rarely require disassembly. Therefore, always follow these preventive measures:

- Never disassemble brake components unless absolutely necessary.
- If any connection on the hydraulic brake system is disconnected, the entire brake system must be disassembled, drained, cleaned, properly filled, and bled after reassembly.
- Never use solvents on internal brake components.
- Use only clean or new brake fluid for cleaning brake components.
- Brake fluid may damage painted surfaces and plastic parts. Therefore, always clean up any spilt brake fluid immediately.
- Avoid brake fluid coming into contact with the eyes as it can cause serious injury.
- **FIRST AID FOR BRAKE FLUID ENTERING THE EYES:**
- Flush with water for 15 minutes and get immediate medical attention.

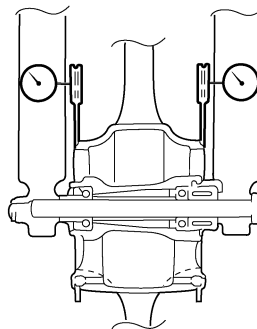

- Place the vehicle on a suitable stand so that the front wheel is elevated.
- Before measuring the front brake disc deflection, turn the handlebar to the left or right to ensure that the front wheel is stationary.
- Remove the brake caliper.
- Hold the dial gauge at a right angle against the brake disc surface.
- Measure the deflection 1.5 mm (0.06 in) below the edge of the brake disc.



- Measure:
  - Brake disc thickness
 Measure the brake disc thickness at a few different locations.  
 Out of specification → Replace.

EAS22240

### CHECKING THE FRONT BRAKE DISCS

The following procedure applies to both brake discs.

- Remove:
  - Front wheel
 Refer to "FRONT WHEEL" on page 4-8.
- Check:
  - Brake disc
 Damage/galling → Replace.
- Measure:
  - Brake disc deflection
 Out of specification → Correct the brake disc deflection or replace the brake disc.



**Brake disc thickness limit**  
0.10 mm (0.0039 in)



**Brake disc thickness limit**  
4.5 mm (0.18 in)

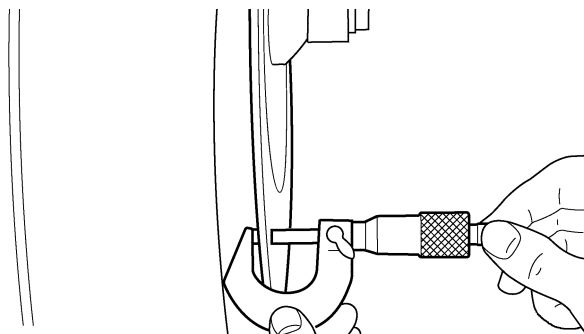

- Adjust:
  - Brake disc deflection



- Remove the brake disc.
- Rotate the brake disc by one bolt hole.
- Install the brake disc.

**NOTE:** Tighten the brake disc bolts in stages and in a crisscross pattern.

# FRONT BRAKE



**Front brake disc bolt**  
**18 Nm (1.8 m·kg, 13 ft·lb)**  
**LOCTITE®**

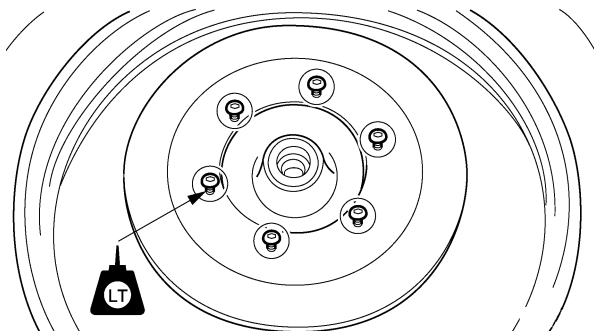

- d. Measure the brake disc deflection.
- e. If out of specification, repeat the adjustment steps until the brake disc deflection is within specification.
- f. If the brake disc deflection cannot be brought within specification, replace the brake disc.



6. Install:
- Front wheel
- Refer to "FRONT WHEEL" on page 4-8.

EAS22260

## REPLACING THE FRONT BRAKE PADS

**NOTE:**

When replacing the brake pads, it is not necessary to disconnect the brake hose or disassemble the brake caliper.

1. Remove:
- Brake hose holder "1"
  - Brake caliper "2"

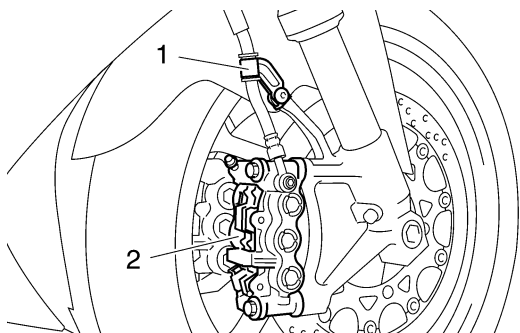

2. Remove:
- Brake pad clips "1"
  - Brake pad pins "2"
  - Brake pad springs "3"

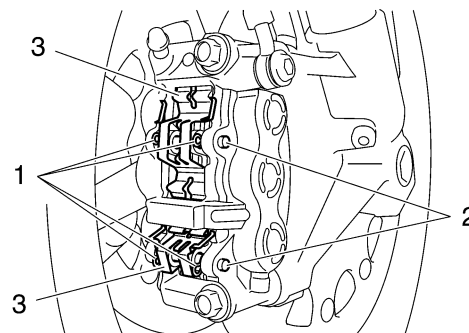

3. Remove:
- Brake pads "1"

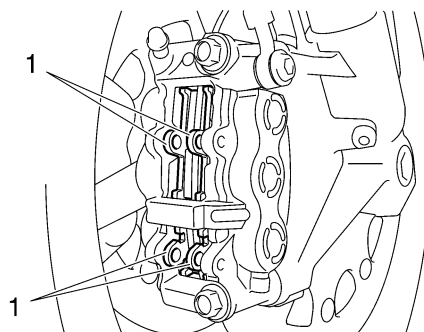

4. Measure:
- Brake pad wear limit "a"
- Out of specification → Replace the brake pads as a set.



<b>Brake pad lining thickness (inner)</b>
4.5 mm (0.18 in)
<b>Limit</b>
0.8 mm (0.03 in)
<b>Brake pad lining thickness (outer)</b>
4.5 mm (0.18 in)
<b>Limit</b>
0.8 mm (0.03 in)

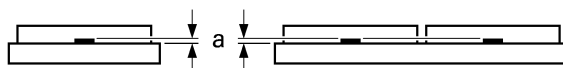

5. Install:
- Brake pads
  - Brake pad spring

# FRONT BRAKE

**NOTE:** \_\_\_\_\_

Always install new brake pads and a new brake pad spring as a set.



- a. Connect a clear plastic hose "1" tightly to the bleed screw "2". Put the other end of the hose into an open container.

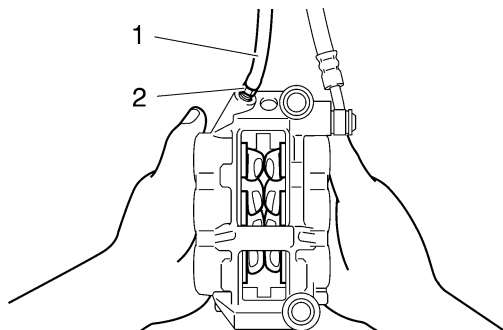

- b. Loosen the bleed screw and push the brake caliper pistons into the brake caliper with your finger.
- c. Tighten the bleed screw.

	<p><b>Bleed screw</b>  <b>6 Nm (0.6 m·kg, 4.3 ft·lb)</b></p>
--	--

- d. Install new brake pads and a new brake pad spring.

**NOTE:** \_\_\_\_\_

The arrow mark "a" on the brake pad springs must point in the direction of disc rotation.

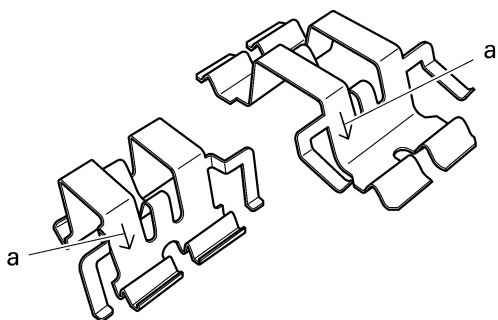

- 6. Install:
  - Brake pad pins
  - Brake pad clips
  - Brake caliper

	<p><b>Front brake caliper bolt</b>  <b>35 Nm (3.5 m·kg, 25 ft·lb)</b></p>
--	---

- 7. Check:
  - Brake fluid level

Below the minimum level mark "a" → Add the recommended brake fluid to the proper level.

Refer to "CHECKING THE BRAKE FLUID LEVEL" on page 3-24.

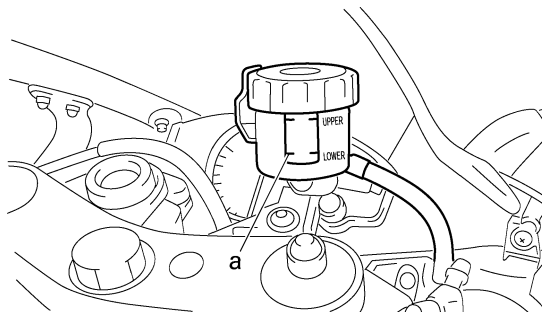

- 8. Check:
  - Brake lever operation

Soft or spongy feeling → Bleed the brake system.

Refer to "BLEEDING THE HYDRAULIC BRAKE SYSTEM" on page 3-26.

EAS22300

**REMOVING THE FRONT BRAKE CALIPERS**

The following procedure applies to both of the brake calipers.

**NOTE:** \_\_\_\_\_

Before removing the brake caliper, drain the brake fluid from the entire brake system.

- 1. Remove:
  - Union bolt "1"
  - Copper washers "2"
  - Brake hose "3"

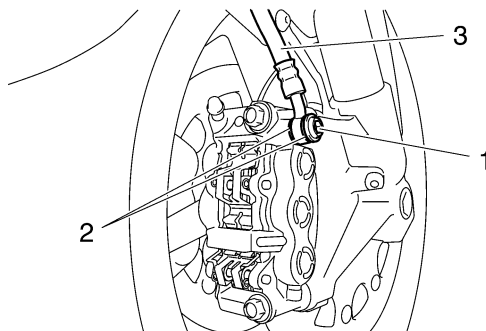

**NOTE:** \_\_\_\_\_

Put the end of the brake hose into a container and pump out the brake fluid carefully.

# FRONT BRAKE

EAS22360

## DISASSEMBLING THE FRONT BRAKE CALIPERS

The following procedure applies to both of the brake calipers.

1. Remove:
  - Brake caliper pistons "1"
  - Brake caliper piston seals "2"

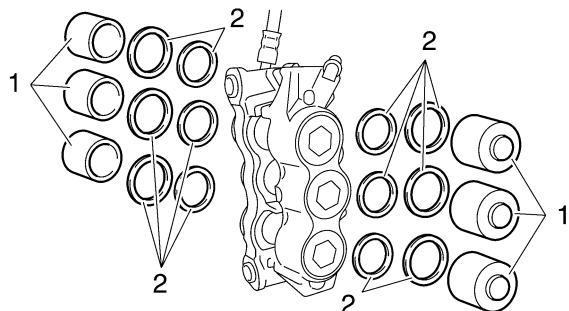

- a. Secure the right side brake caliper pistons with a piece of wood "a".
- b. Blow compressed air into the brake hose joint opening "b" to force out the left side pistons from the brake caliper.

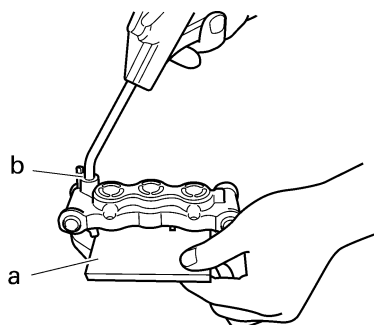

EWA4C81005

**WARNING**

- Never try to pry out the brake caliper pistons.
- Do not loosen the bolts "3".

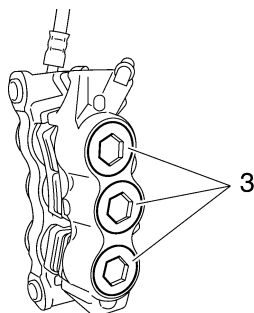

- c. Remove the brake caliper piston seals.
- d. Repeat the previous steps to force out the right side pistons from the brake caliper.



EAS22390

## CHECKING THE FRONT BRAKE CALIPERS

Recommended brake component replacement schedule	
Brake pads	If necessary
Piston seals	Every two years
Brake hoses	Every four years
Brake fluid	Every two years and whenever the brake is disassembled

1. Check:
  - Brake caliper pistons "1"  
Rust/scratches/wear → Replace the brake caliper pistons.
  - Brake caliper cylinders "2"  
Scratches/wear → Replace the brake caliper assembly.
  - Brake caliper body "3"  
Cracks/damage → Replace the brake caliper assembly.
  - Brake fluid delivery passages (brake caliper body)  
Obstruction → Blow out with compressed air.

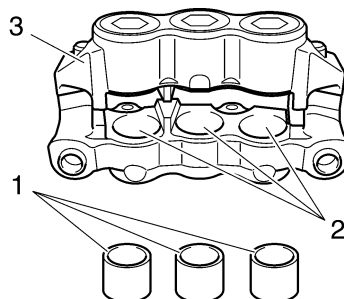

EWA13600

**WARNING**

Whenever a brake caliper is disassembled, replace the piston seals.

EAS22410

## ASSEMBLING THE FRONT BRAKE CALIPERS

EWA13620

**WARNING**

- Before installation, all internal brake components should be cleaned and lubricated with clean or new brake fluid.
- Never use solvents on internal brake components as they will cause the piston seals to swell and distort.

## FRONT BRAKE

- Whenever a brake caliper is disassembled, replace the brake caliper piston seals.



**Recommended fluid  
DOT 4**

EAS22450

### INSTALLING THE FRONT BRAKE CALI-PERS

The following procedure applies to both of the brake calipers.

1. Install:
  - Brake pads
  - Brake pad springs
  - Brake pad pins
2. Install:
  - Brake caliper "1"
  - Copper washers **New**
  - Brake hose "2"
  - Union bolt "3"
  - Brake hose holder



**Front brake caliper bolt  
35 Nm (3.5 m·kg, 25 ft·lb)  
Front brake hose union bolt  
30 Nm (3.0 m·kg, 22 ft·lb)  
Front brake hose holder  
6 Nm (0.6 m·kg, 4.3 ft·lb)**

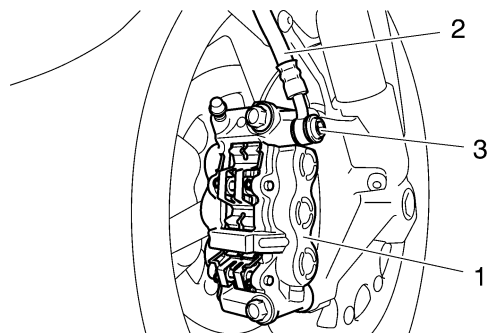

EWA13530



**Proper brake hose routing is essential to insure safe vehicle operation. Refer to "CABLE ROUTING" on page 2-39.**

ECA14170

**CAUTION:**

**When installing the brake hose onto the brake caliper "1", make sure the brake pipe "a" touches the projection "b" on the brake caliper.**

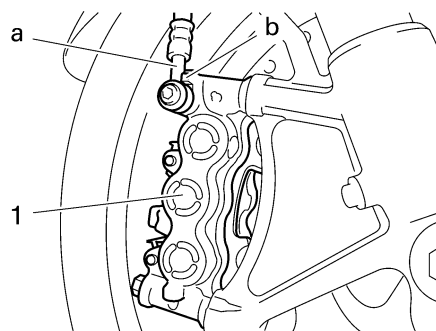

3. Fill:
  - Brake fluid reservoir (with the specified amount of the recommended brake fluid)



**Recommended fluid  
DOT 4**

EWA13090

**WARNING**

- Use only the designated brake fluid. Other brake fluids may cause the rubber seals to deteriorate, causing leakage and poor brake performance.
- Refill with the same type of brake fluid that is already in the system. Mixing brake fluids may result in a harmful chemical reaction, leading to poor brake performance.
- When refilling, be careful that water does not enter the brake fluid reservoir. Water will significantly lower the boiling point of the brake fluid and could cause vapor lock.

ECA13540

**CAUTION:**

**Brake fluid may damage painted surfaces and plastic parts. Therefore, always clean up any spilt brake fluid immediately.**

4. Bleed:
  - Brake system  
Refer to "BLEEDING THE HYDRAULIC BRAKE SYSTEM" on page 3-26.
5. Check:
  - Brake fluid level  
Below the minimum level mark "a" → Add the recommended brake fluid to the proper level.  
Refer to "CHECKING THE BRAKE FLUID LEVEL" on page 3-24.

## FRONT BRAKE

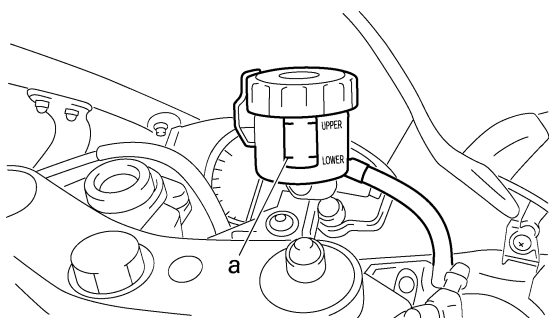

6. Check:
- Brake lever operation  
Soft or spongy feeling → Bleed the brake system.  
Refer to "BLEEDING THE HYDRAULIC BRAKE SYSTEM" on page 3-26.

EAS22490

### REMOVING THE FRONT BRAKE MASTER CYLINDER

**NOTE:**

Before removing the front brake master cylinder, drain the brake fluid from the entire brake system.

1. Disconnect:
  - Brake switch coupler "1" (from the brake switch)
2. Remove:
  - Union bolt "2"
  - Copper washers "3"
  - Brake hoses "4"

**NOTE:**

To collect any remaining brake fluid, place a container under the master cylinder and the end of the brake hose.

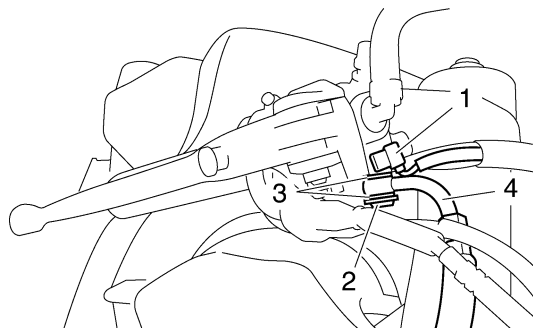

3. Remove:
  - Brake master cylinder holder
  - Brake master cylinder

EAS22510

### CHECKING THE FRONT BRAKE MASTER CYLINDER

1. Check:
  - Brake master cylinder  
Damage/scratches/wear → Replace.
  - Brake fluid delivery passages (brake master cylinder body)  
Obstruction → Blow out with compressed air.

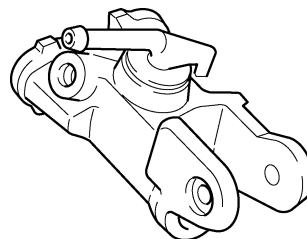

2. Check:
  - Brake master cylinder kit  
Damage/scratches/wear → Replace.

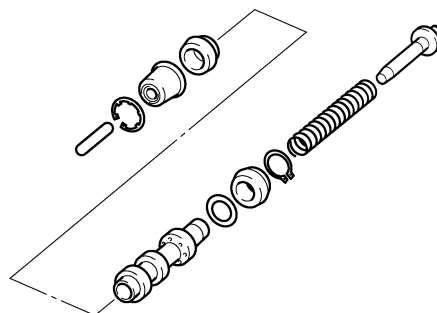

3. Check:
  - Brake fluid reservoir tank "1"  
Cracks/damage → Replace.
  - Brake fluid reservoir diaphragm "2"  
Damage/wear → Replace.

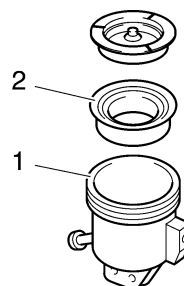

4. Check:
  - Brake hose "3"  
Cracks/damage/wear → Replace.

## FRONT BRAKE

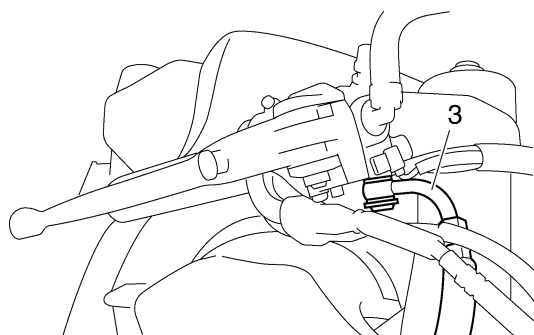

EAS22520

### ASSEMBLING THE FRONT BRAKE MASTER CYLINDER

EWA13520

#### WARNING

- Before installation, all internal brake components should be cleaned and lubricated with clean or new brake fluid.
- Never use solvents on internal brake components.

	<b>Recommended fluid DOT 4</b>
--	------------------------------------

1. Instal:

- Brake master cylinder kit **New**

EAS22540

### INSTALLING THE FRONT BRAKE MASTER CYLINDER

1. Install:

- Brake master cylinder "1"
- Brake master cylinder holder "2"

	<b>Front brake master cylinder holder bolt 13 Nm (1.3 m·kg, 9.4 ft·lb)</b>
--	--

**NOTE:**

- Install the brake master cylinder holder with the "UP" mark "a" facing up.
- Align the end of the brake master cylinder holder with the punch mark "b" on the handlebar.
- First, tighten the upper bolt, then the lower bolt.
- There should be 2–2.5 mm (0.08–0.10 in) of clearance between the right handlebar switch and the brake master cylinder holder.

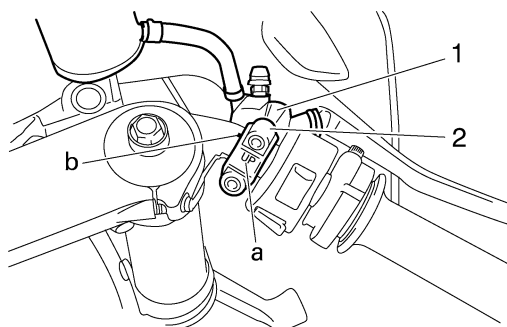

2. Install:

- Copper washers **New**
- Brake hose
- Union bolt

	<b>Front brake hose union bolt 30 Nm (3.0 m·kg, 22 ft·lb)</b>
--	---

EWA13530

#### WARNING

**Proper brake hose routing is essential to insure safe vehicle operation. Refer to "CABLE ROUTING" on page 2-39.**

**NOTE:**

- While holding the brake hose, tighten the union bolt as shown.
- Turn the handlebar to the left and right to make sure the brake hose does not touch other parts (e.g., wire harness, cables, leads). Correct if necessary.

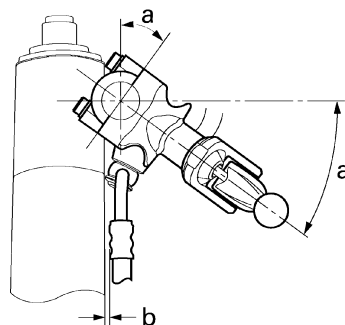

- a. 36°
  - b. 3 mm (0.12 in)
3. Fill:
- Brake fluid reservoir (with the specified amount of the recommended brake fluid)

	<b>Recommended fluid DOT 4</b>
--	------------------------------------

## FRONT BRAKE

EWA13090

### **WARNING**

- **Use only the designated brake fluid.** Other brake fluids may cause the rubber seals to deteriorate, causing leakage and poor brake performance.
- **Refill with the same type of brake fluid that is already in the system.** Mixing brake fluids may result in a harmful chemical reaction, leading to poor brake performance.
- **When refilling, be careful that water does not enter the brake fluid reservoir.** Water will significantly lower the boiling point of the brake fluid and could cause vapor lock.

ECA13540

### **CAUTION:**

**Brake fluid may damage painted surfaces and plastic parts. Therefore, always clean up any spilt brake fluid immediately.**

#### 4. Bleed:

- Brake system  
Refer to "BLEEDING THE HYDRAULIC BRAKE SYSTEM" on page 3-26.

#### 5. Check:

- Brake fluid level  
Below the minimum level mark "a" → Add the recommended brake fluid to the proper level.  
Refer to "CHECKING THE BRAKE FLUID LEVEL" on page 3-24.

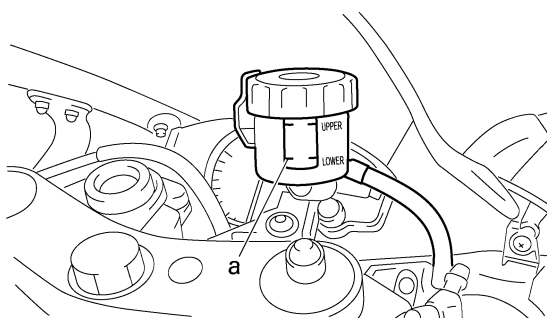

#### 6. Check:

- Brake lever operation  
Soft or spongy feeling → Bleed the brake system.  
Refer to "BLEEDING THE HYDRAULIC BRAKE SYSTEM" on page 3-26.

# REAR BRAKE

EAS22550

## REAR BRAKE

### Removing the rear brake pads

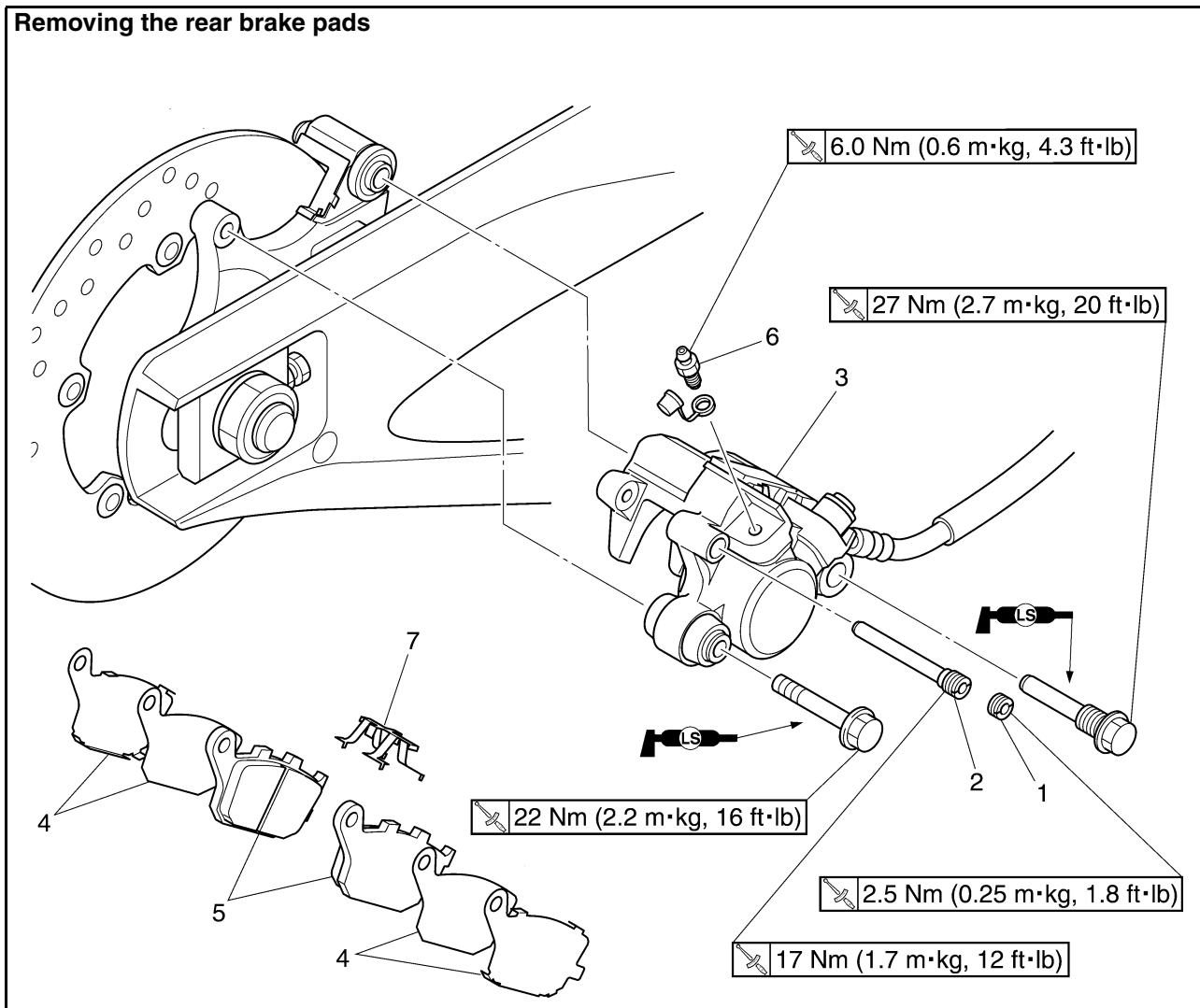

Order	Job/Parts to remove	Q'ty	Remarks
1	Screw plug	1	
2	Brake pad pin	1	
3	Rear brake caliper	1	
4	Brake pad shim	4	
5	Brake pad	2	
6	Bleed screw	1	
7	Brake pad spring	1	
			For installation, reverse the removal procedure.

## REAR BRAKE

### Removing the rear brake master cylinder

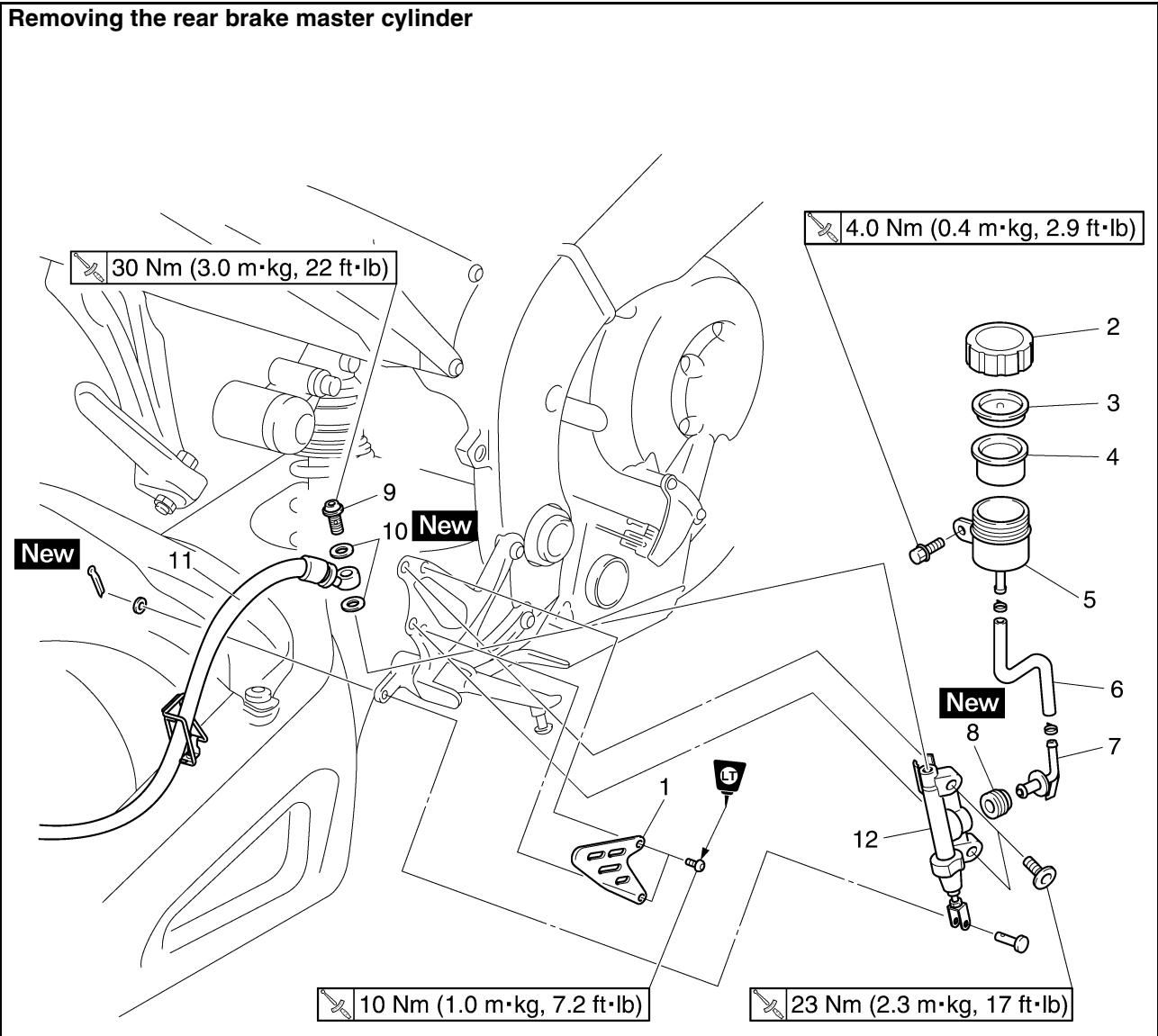

Order	Job/Parts to remove	Q'ty	Remarks
	Brake fluid		Drain. Refer to "BLEEDING THE HYDRAULIC BRAKE SYSTEM" on page 3-26.
1	Footrest plate	1	
2	Brake fluid reservoir cap	1	
3	Rear brake fluid reservoir diaphragm holder	1	
4	Rear brake fluid reservoir diaphragm	1	
5	Brake fluid reservoir tank	1	
6	Brake fluid reservoir hose	1	
7	Hose joint	1	
8	Bush	1	
9	Union bolt	1	
10	Copper washer	2	
11	Brake hose	1	
12	Brake master cylinder	1	
			For installation, reverse the removal procedure.

## REAR BRAKE

### Disassembling the rear brake master cylinder

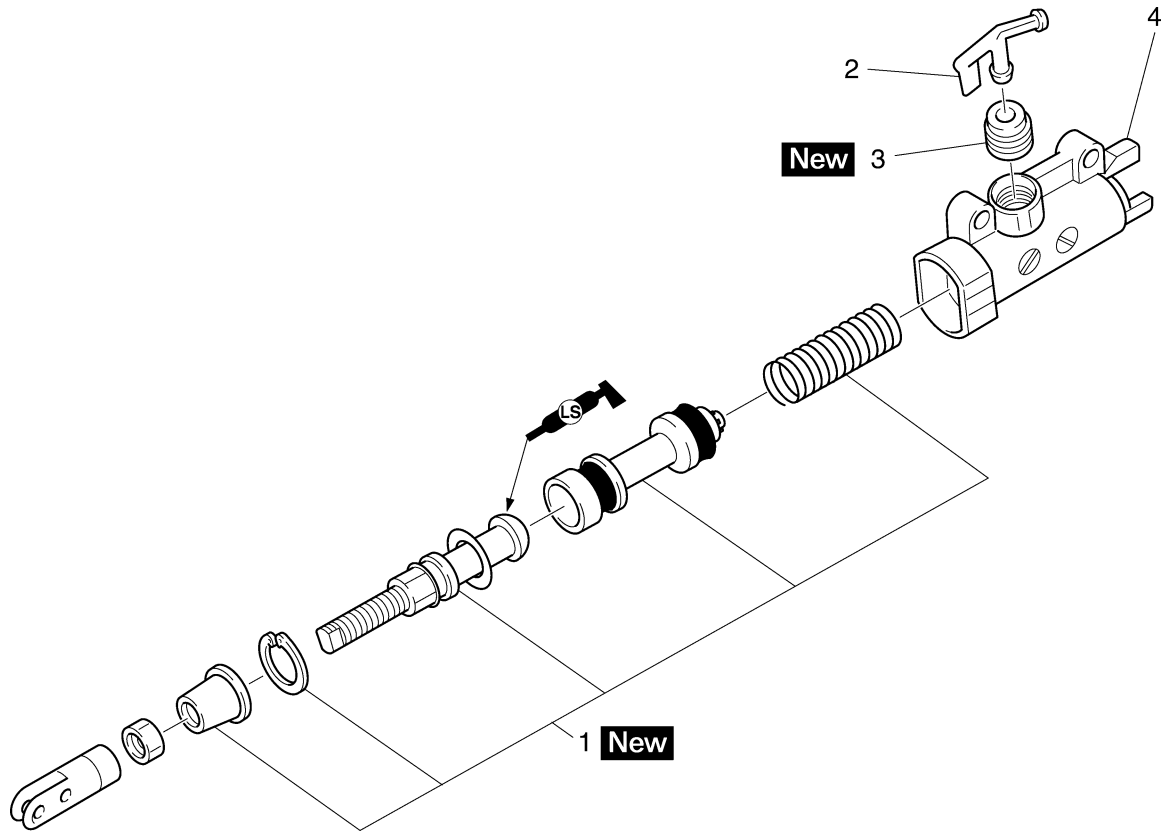

Order	Job/Parts to remove	Q'ty	Remarks
1	Brake master cylinder kit	1	
2	Hose joint	1	
3	Bush	1	
4	Brake master cylinder body	1	
			For assembly, reverse the disassembly procedure.

## REAR BRAKE

### Removing the rear brake calipers

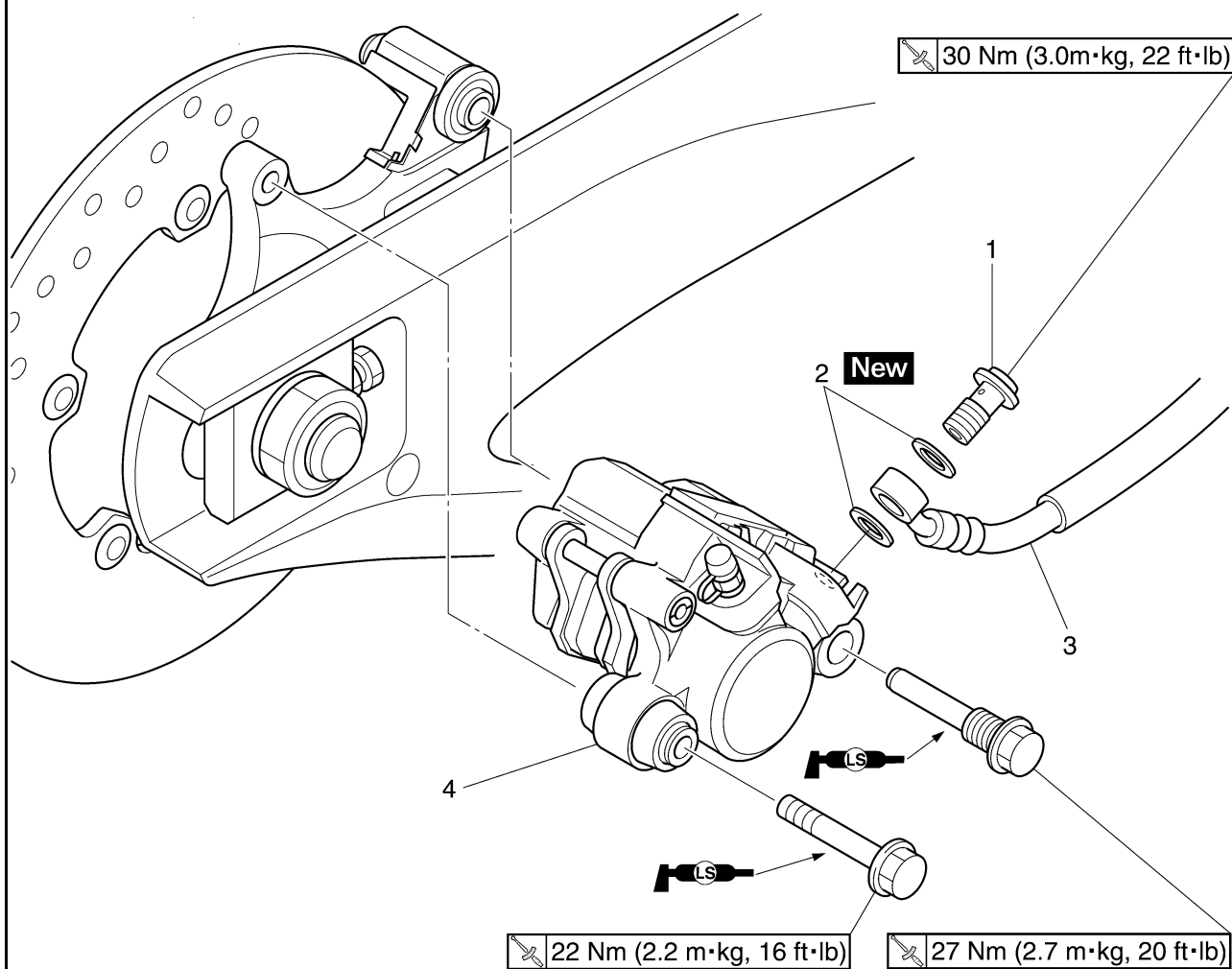

Order	Job/Parts to remove	Q'ty	Remarks
	Brake fluid		Drain. Refer to "BLEEDING THE HYDRAULIC BRAKE SYSTEM" on page 3-26.
1	Union bolt	1	
2	Copper washer	2	
3	Brake hose	1	
4	Brake caliper	1	
			For installation, reverse the removal procedure.

## REAR BRAKE

### Disassembling the rear brake calipers

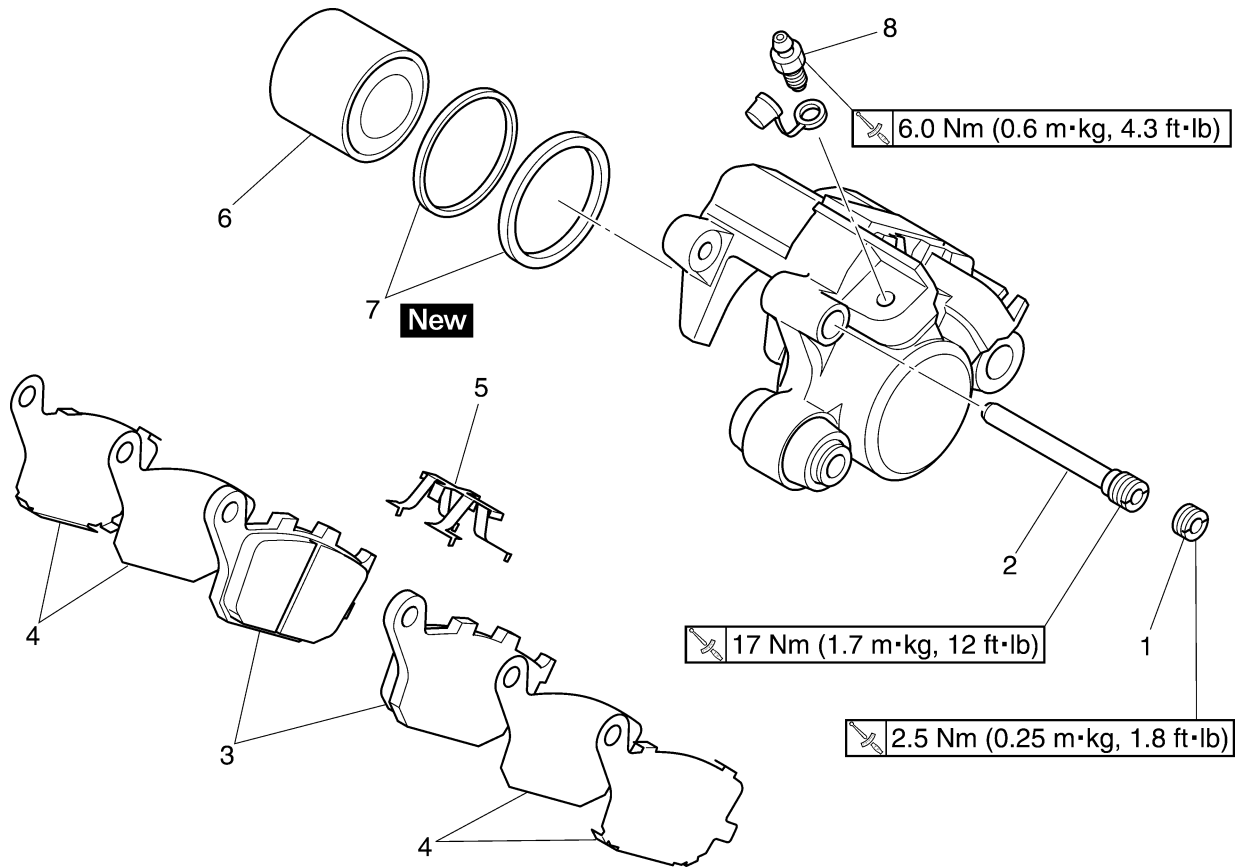

Order	Job/Parts to remove	Q'ty	Remarks
1	Screw plug	1	
2	Brake pad pin	1	
3	Brake pad	2	
4	Brake pad shim	4	
5	Brake pad spring	1	
6	Brake caliper piston	1	
7	Brake caliper piston seal	2	
8	Bleed screw	1	
			For assembly, reverse the disassembly procedure.

## REAR BRAKE

EAS22560

### INTRODUCTION

EWA14100

#### WARNING

Disc brake components rarely require disassembly. Therefore, always follow these preventive measures:

- Never disassemble brake components unless absolutely necessary.
- If any connection on the hydraulic brake system is disconnected, the entire brake system must be disassembled, drained, cleaned, properly filled, and bled after reassembly.
- Never use solvents on internal brake components.
- Use only clean or new brake fluid for cleaning brake components.
- Brake fluid may damage painted surfaces and plastic parts. Therefore, always clean up any spilt brake fluid immediately.
- Avoid brake fluid coming into contact with the eyes as it can cause serious injury.
- **FIRST AID FOR BRAKE FLUID ENTERING THE EYES:**
- Flush with water for 15 minutes and get immediate medical attention.

EAS22570

### CHECKING THE REAR BRAKE DISC

1. Remove:
  - Rear wheel  
Refer to "REAR WHEEL" on page 4-14.
2. Check:
  - Brake disc  
Damage/galling → Replace.
3. Measure:
  - Brake disc deflection  
Out of specification → Correct the brake disc deflection or replace the brake disc.  
Refer to "CHECKING THE FRONT BRAKE DISCS" on page 4-25.



**Brake disc deflection limit**  
**0.15 mm (0.0059 in)**

4. Measure:
  - Brake disc thickness  
Measure the brake disc thickness at a few different locations.  
Out of specification → Replace.  
Refer to "CHECKING THE FRONT BRAKE DISCS" on page 4-25.



**Brake disc thickness limit**  
**4.5 mm (0.18 in)**

5. Adjust:
  - Brake disc deflection  
Refer to "CHECKING THE FRONT BRAKE DISCS" on page 4-25.



**Rear brake disc bolt**  
**30 Nm (3.0 m.kg, 22 ft.-lb)**  
**LOCTITE®**

6. Install:
  - Rear wheel  
Refer to "REAR WHEEL" on page 4-14.

EAS22580

### REPLACING THE REAR BRAKE PADS

#### NOTE:

When replacing the brake pads, it is not necessary to disconnect the brake hose or disassemble the brake caliper.

1. Remove :
  - Screw plug "1"
  - Brake pad pin "2"
  - Brake caliper "3"
  - Brake pad spring

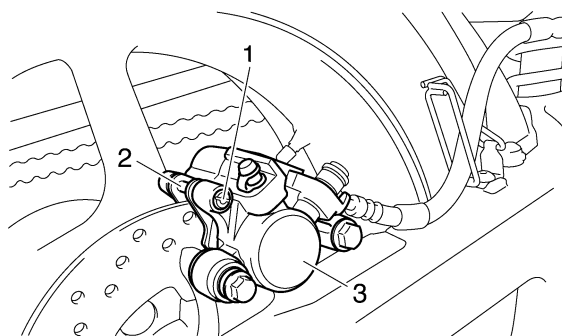

2. Remove :
  - Brake pads "1"  
(along with the brake pad shims "2")

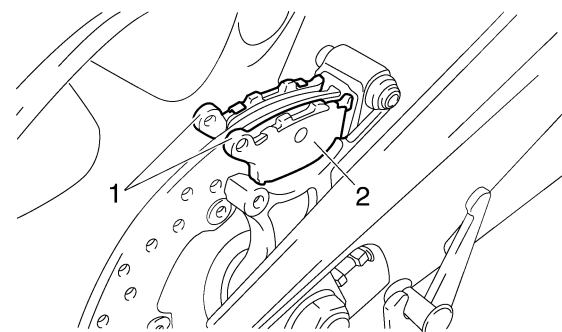

## REAR BRAKE

3. Measure:
- Brake pad wear limit "a"  
Out of specification → Replace the brake pads as a set.

	<b>Brake pad lining thickness (inner)</b>
	<b>6.0 mm (0.24 in)</b>
	<b>Limit</b>
	<b>1.0 mm (0.04 in)</b>
	<b>Brake pad lining thickness (outer)</b>
	<b>6.0 mm (0.24 in)</b>
	<b>Limit</b>
	<b>1.0 mm (0.04 in)</b>

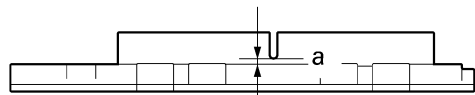

4. Install:
- Brake pad shims (onto the brake pads)
  - Brake pads
  - Brake pad spring

**NOTE:** Always install new brake pads, brake pad shims, and a brake pad spring as a set.

- a. Connect a clear plastic hose "1" tightly to the bleed screw "2". Put the other end of the hose into an open container.

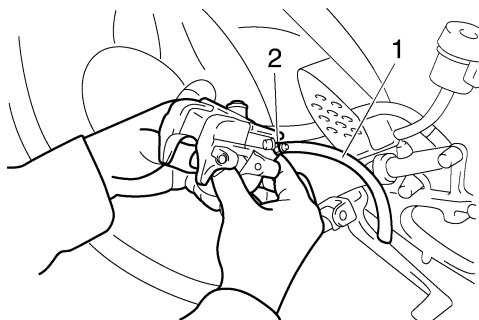

- b. Loosen the bleed screw and push the brake caliper pistons into the brake caliper with your finger.

- c. Tighten the bleed screw.

	<b>Bleed screw</b> <b>6 Nm (0.6 m·kg, 4.3 ft·lb)</b>
---	---

- d. Install a new brake pad shim "3" onto each new brake pad "4".

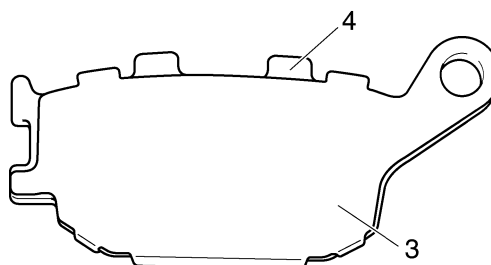

5. Install:
- Brake pad pin
  - Screw plug
  - Brake caliper

	<b>Rear brake caliper bolt (front side)</b> <b>27 Nm (2.7 m·kg, 20 ft·lb)</b>
	<b>Rear brake caliper bolt (rear side)</b> <b>22 Nm (2.2 m·kg, 16 ft·lb)</b>

6. Check:
- Brake fluid level  
Below the minimum level mark "a" → Add the recommended brake fluid to the proper level.  
Refer to "CHECKING THE BRAKE FLUID LEVEL" on page 3-24.

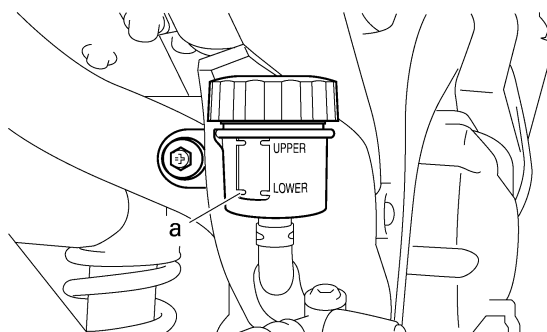

7. Check:
- Brake pedal operation  
Soft or spongy feeling → Bleed the brake system.  
Refer to "BLEEDING THE HYDRAULIC BRAKE SYSTEM" on page 3-26.

## REAR BRAKE

EAS22590

### REMOVING THE REAR BRAKE CALIPER

**NOTE:**

Before disassembling the brake caliper, drain the brake fluid from the entire brake system.

- Remove:
  - Union bolt "1"
  - Copper washers "2"
  - Brake hose "3"
  - Brake caliper "4"

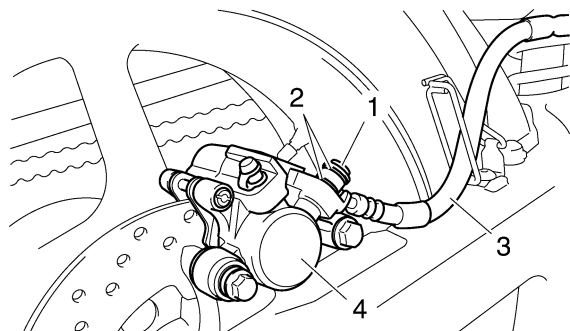

**NOTE:**

Put the end of the brake hose into a container and pump out the brake fluid carefully.

EAS22600

### DISASSEMBLING THE REAR BRAKE CALIPER

- Remove:
  - Brake caliper piston "1"
  - Brake caliper piston seals "2"

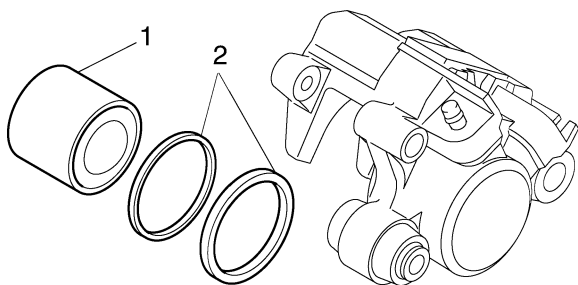

- Secure the brake caliper piston with a piece of wood "a"
- Blow compressed air into the brake hose joint opening "b" to force out the piston from the brake caliper.

EWA13550

**WARNING**

- Cover the brake caliper piston with a rag. Be careful not to get injured when the piston is expelled from the brake caliper.

- Never try to pry out the brake caliper piston.

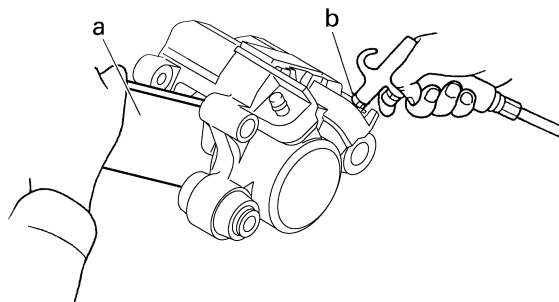

- Remove the brake caliper piston seals.



EAS22640

### CHECKING THE REAR BRAKE CALIPER

Recommended brake component replacement schedule	
Brake pads	If necessary
Piston seals	Every two years
Brake hoses	Every four years
Brake fluid	Every two years and whenever the brake is disassembled

- Check:
  - Brake caliper pistons "1"  
Rust/scratches/wear → Replace the brake caliper pistons.
  - Brake caliper cylinders "2"  
Scratches/wear → Replace the brake caliper assembly.
  - Brake caliper body "3"  
Cracks/damage → Replace the brake caliper assembly.
  - Brake fluid delivery passages (brake caliper body)  
Obstruction → Blow out with compressed air.

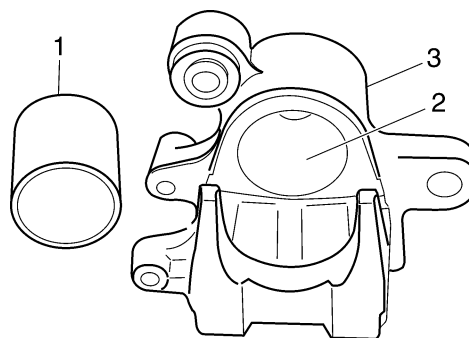

## REAR BRAKE

EWA13610

### WARNING

Whenever a brake caliper is disassembled, replace the brake caliper piston seals.

2. Check:

- Brake caliper bracket "1"  
Cracks/damage → Replace.

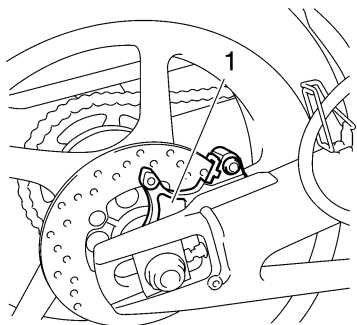

EAS22650

### ASSEMBLING THE REAR BRAKE CALIPER

EWA13620

### WARNING

- Before installation, all internal brake components should be cleaned and lubricated with clean or new brake fluid.
- Never use solvents on internal brake components as they will cause the piston seals to swell and distort.
- Whenever a brake caliper is disassembled, replace the brake caliper piston seals.



Recommended fluid  
DOT 4

EAS22670

### INSTALLING THE REAR BRAKE CALIPER

1. Install:

- Brake caliper "1"  
(temporarily)
- Copper washers **New**
- Brake hose "2"
- Union bolt "3"



Rear brake hose union bolt  
30 Nm (3.0 m·kg, 22 ft·lb)

EWA13530

### WARNING

Proper brake hose routing is essential to insure safe vehicle operation. Refer to "CABLE ROUTING" on page 2-39.

ECA14170

### CAUTION:

When installing the brake hose onto the brake caliper "1", make sure the brake pipe "a" touches the projection "b" on the brake caliper.

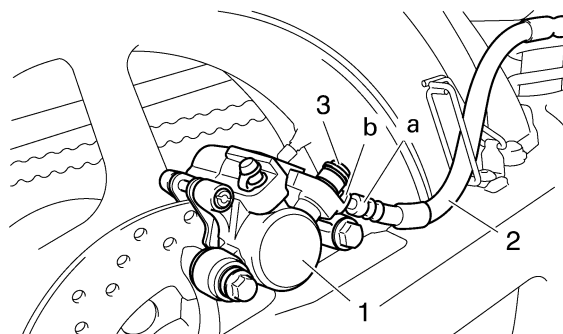

2. Remove:

- Brake caliper

3. Install:

- Brake pad shims
- Brake pads
- Brake pad spring
- Brake pad pin
- Screw plug
- Brake caliper

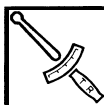

Rear brake caliper bolt (front side)

27 Nm (2.7 m·kg, 20 ft·lb)

Rear brake caliper bolt (rear side)

22 Nm (2.2 m·kg, 16 ft·lb)

4. Fill:

- Brake fluid reservoir  
(with the specified amount of the recommended brake fluid)



Recommended fluid  
DOT 4

EWA13090

### WARNING

- Use only the designated brake fluid. Other brake fluids may cause the rubber seals to deteriorate, causing leakage and poor brake performance.
- Refill with the same type of brake fluid that is already in the system. Mixing brake fluids may result in a harmful chemical reaction, leading to poor brake performance.

## REAR BRAKE

- When refilling, be careful that water does not enter the brake fluid reservoir. Water will significantly lower the boiling point of the brake fluid and could cause vapor lock.

ECA13540

**CAUTION:**

**Brake fluid may damage painted surfaces and plastic parts. Therefore, always clean up any spilt brake fluid immediately.**

5. Bleed:
  - Brake system  
Refer to "BLEEDING THE HYDRAULIC BRAKE SYSTEM" on page 3-26.
6. Check:
  - Brake fluid level  
Below the minimum level mark "a" → Add the recommended brake fluid to the proper level.  
Refer to "CHECKING THE BRAKE FLUID LEVEL" on page 3-24.

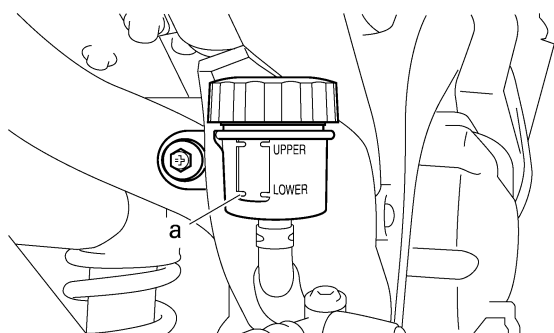

7. Check:
  - Brake pedal operation  
Soft or spongy feeling → Bleed the brake system.  
Refer to "BLEEDING THE HYDRAULIC BRAKE SYSTEM" on page 3-26.

EAS22700

### REMOVING THE REAR BRAKE MASTER CYLINDER

1. Remove:
  - Union bolt "1"
  - Copper washers "2"
  - Brake hose "3"

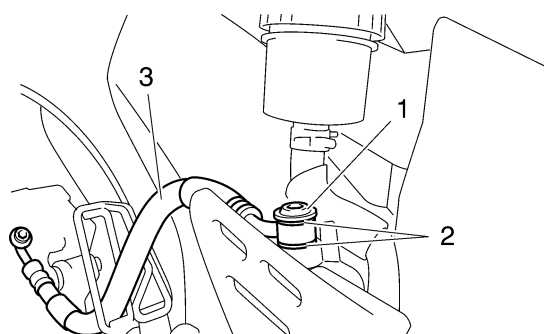

**NOTE:**

To collect any remaining brake fluid, place a container under the master cylinder and the end of the brake hose.

2. Remove:
  - Brake master cylinder

EAS22720

### CHECKING THE REAR BRAKE MASTER CYLINDER

1. Check:
  - Brake master cylinder  
Damage/scratches/wear → Replace.
  - Brake fluid delivery passages (brake master cylinder body)  
Obstruction → Blow out with compressed air.

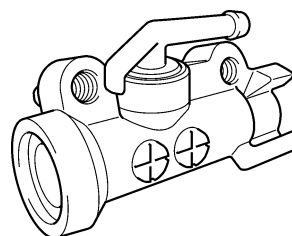

2. Check:
  - Brake master cylinder kit  
Damage/scratches/wear → Replace.

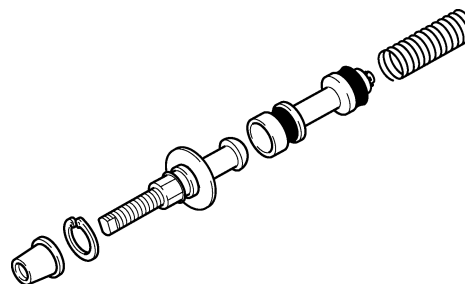

3. Check:
  - Brake fluid reservoir tank "1"  
Cracks/damage → Replace.
  - Brake fluid reservoir diaphragm "2"  
Cracks/damage → Replace.

## REAR BRAKE

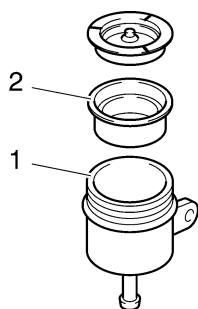

4. Check:

- Brake hoses "1"  
Cracks/damage/wear → Replace.

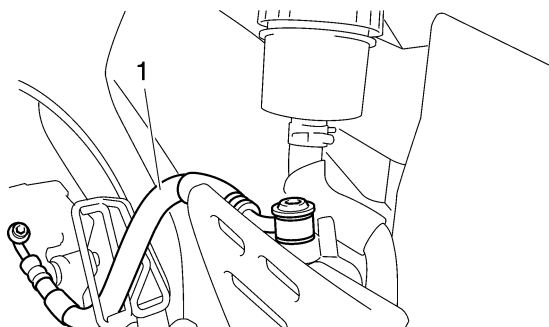

EAS22730

### ASSEMBLING THE REAR BRAKE MASTER CYLINDER

EWA13520

#### ⚠ WARNING

- Before installation, all internal brake components should be cleaned and lubricated with clean or new brake fluid.
- Never use solvents on internal brake components.



1. Instal:

- Brake master cylinder kit **New**

EAS22740

### INSTALLING THE REAR BRAKE MASTER CYLINDER

1. Install:

- Copper washers **New**
- Brake hoses
- Union bolt

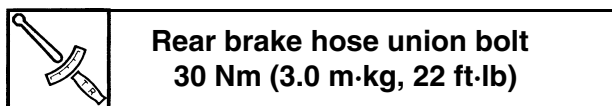

EWA13530

#### ⚠ WARNING

Proper brake hose routing is essential to insure safe vehicle operation. Refer to "CABLE ROUTING" on page 2-39.

ECA14160

#### CAUTION:

When installing the brake hose onto the brake master cylinder, make sure the brake pipe touches the projection "a" as shown.

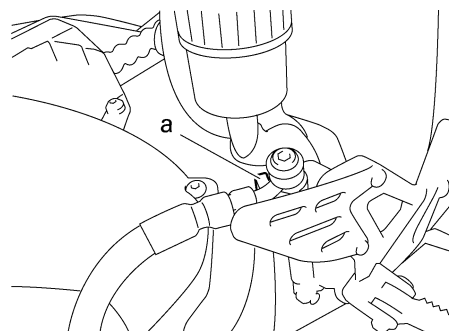

2. Fill:

- Brake fluid reservoir  
(to the maximum level mark "b")

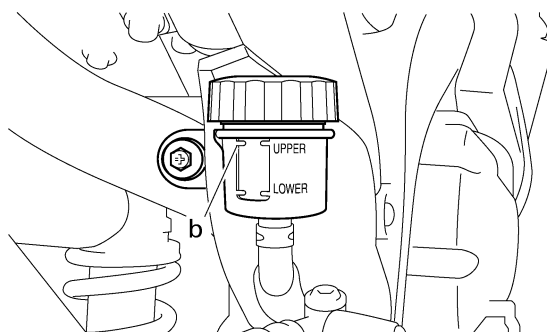

EWA13090

#### ⚠ WARNING

- Use only the designated brake fluid. Other brake fluids may cause the rubber seals to deteriorate, causing leakage and poor brake performance.
- Refill with the same type of brake fluid that is already in the system. Mixing brake fluids may result in a harmful chemical reaction, leading to poor brake performance.

## REAR BRAKE

- When refilling, be careful that water does not enter the brake fluid reservoir. Water will significantly lower the boiling point of the brake fluid and could cause vapor lock.

ECA13540

**CAUTION:**

**Brake fluid may damage painted surfaces and plastic parts. Therefore, always clean up any spilt brake fluid immediately.**

3. Bleed:

- Brake system  
Refer to "BLEEDING THE HYDRAULIC BRAKE SYSTEM" on page 3-26.

4. Check:

- Brake fluid level  
Below the minimum level mark "a" → Add the recommended brake fluid to the proper level.  
Refer to "CHECKING THE BRAKE FLUID LEVEL" on page 3-24.

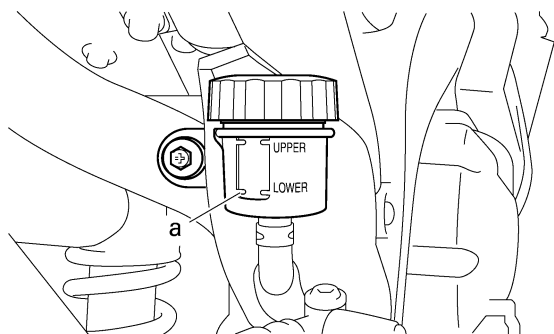

5. Adjust:

- Brake pedal position  
Refer to "ADJUSTING THE REAR DISC BRAKE" on page 3-23.

6. Adjust:

- Rear brake light operation timing  
Refer to "ADJUSTING THE REAR BRAKE LIGHT SWITCH" on page 3-25.

# HANDLEBARS

EAS22850

## HANDLEBARS

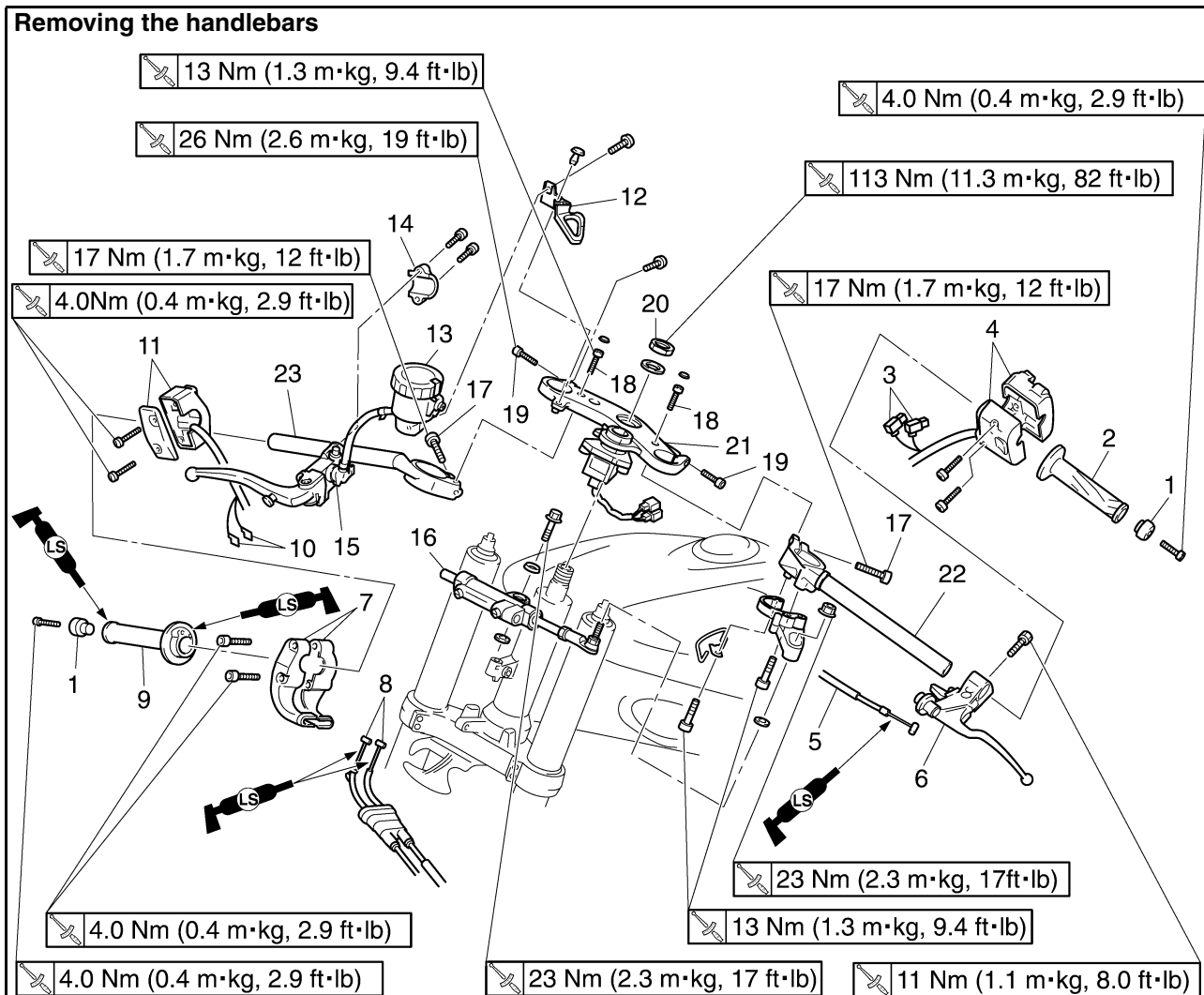

Order	Job/Parts to remove	Q'ty	Remarks
	Front cowling		Refer to "GENERAL CHASSIS" on page 4-1.
	Side cowling		Refer to "GENERAL CHASSIS" on page 4-1.
1	Grip end	2	
2	Handlebar grip	1	
3	Clutch switch connector	2	Disconnect.
4	Left handlebar switch	1	
5	Clutch cable	1	
6	Clutch lever holder	1	
7	Throttle cable housing	1	
8	Throttle cable	2	
9	Throttle grip	1	
10	Front brake light switch lead connector	2	Disconnect.
11	Right handlebar switch	1	
12	Clutch cable holder	1	
13	Brake fluid reservoir tank	1	
14	Brake master cylinder holder	1	
15	Brake master cylinder	1	
16	Steering damper	1	
17	Handlebar pinch bolt	2	Loosen.

# HANDLEBARS

**Removing the handlebars**

The diagram shows the removal of the left and right handlebars from the motorcycle's steering assembly. It includes callouts for various bolts and nuts with their respective torque specifications in Nm, m·kg, and ft·lb. The parts are numbered 1 through 23. Torque specifications include 13 Nm, 26 Nm, 17 Nm, 4.0 Nm, 113 Nm, 23 Nm, and 11 Nm.

Order	Job/Parts to remove	Q'ty	Remarks
18	Upper bracket bolt	2	Loosen.
19	Upper bracket pinch bolt	2	Loosen.
20	Steering stem nut	1	Loosen.
21	Upper bracket	1	
22	Left handlebar	1	
23	Right handlebar	1	
			For installation, reverse the removal procedure.

## HANDLEBARS

EAS22870

### REMOVING THE HANDLEBAR

1. Stand the vehicle on a level surface.

EWA13120

#### **WARNING**

Securely support the vehicle so that there is no danger of it falling over.

2. Remove:

- Handlebar grip "1"

#### NOTE:

Blow compressed air between the handlebar and the handlebar grip, and gradually push the grip off the handlebar.

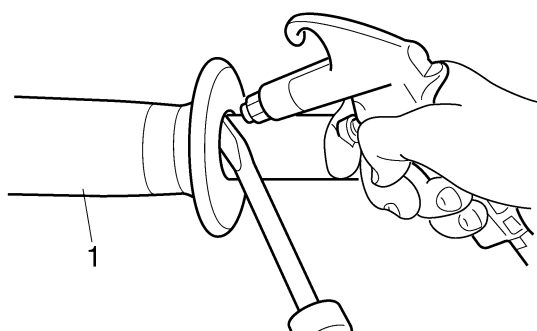

3. Remove:

- Throttle cable housing "1"
- Throttle grip "2"

#### NOTE:

While removing the throttle cable housing, pull back the rubber cover "3".

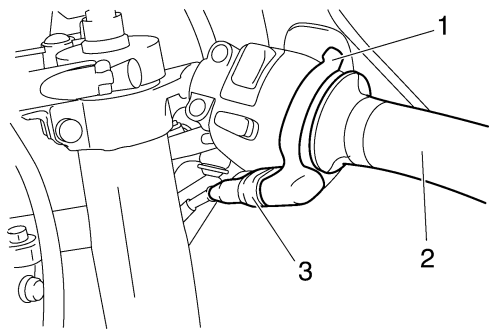

EAS22890

### CHECKING THE HANDLEBARS

1. Check:

- Left handlebar "1"
  - Right handlebar "2"
- Bends/cracks/damage → Replace.

EWA13690

#### **WARNING**

Do not attempt to straighten a bent handlebar as this may dangerously weaken it.

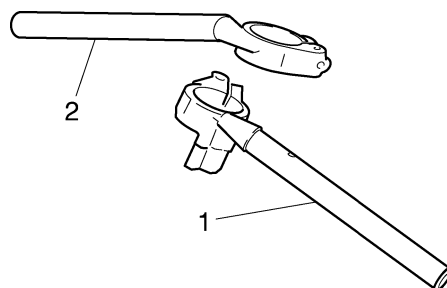

EAS22900

### INSTALLING THE HANDLEBARS

1. Stand the vehicle on a level surface.

EWA13120

#### **WARNING**

Securely support the vehicle so that there is no danger of it falling over.

2. Install:

- Right handlebar switch "1"

#### NOTE:

Align the projection "a" on the right handlebar switch with the hole "b" on the right handlebar.

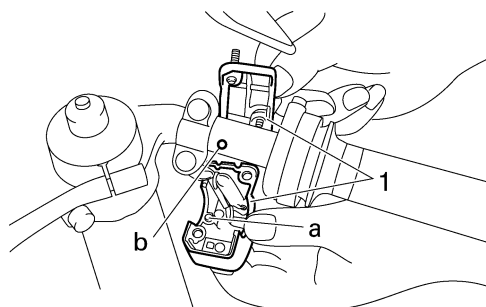

3. Install:

- Brake master cylinder holder "1"

ECA14260

#### **CAUTION:**

- Install the brake master cylinder holder with the "UP" mark facing up.
- First, tighten the upper bolt, and then the lower bolt.

#### NOTE:

- Align the mating surfaces of the brake master cylinder holder with the punch mark "a" on the right handlebar.
- There should be 2–2.5 mm (0.08–0.10 in) of clearance between the right handlebar switch and the brake master cylinder holder.



**Front brake master cylinder holder bolt**  
13 Nm (1.3 m·kg, 9.4 ft·lb)

## HANDLEBARS

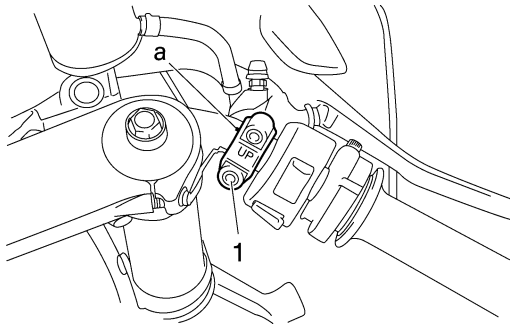

4. Install:

- Throttle grip
- Throttle cable housing “1”
- Throttle cables

**NOTE:**

Align the projection “a” on the throttle cable housing with the hole “b” in the right handlebar.

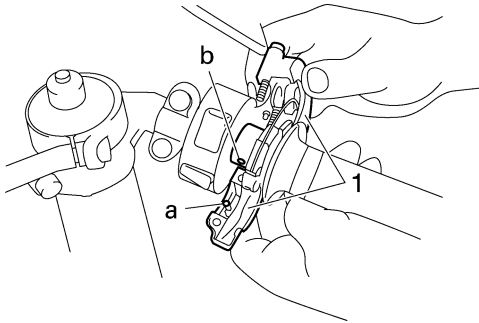

5. Install:

- Clutch lever holder “1”

**NOTE:**

Align the slit on the clutch lever holder with the punch mark “a” on the left handlebar.

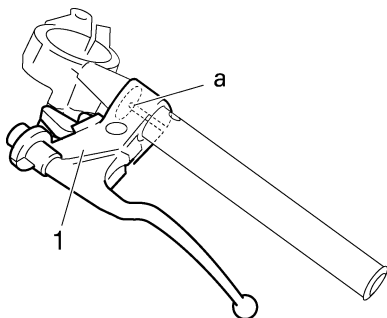

6. Install:

- Left handlebar switch “1”

**NOTE:**

Align the projection “a” on the left handlebar switch with the hole “b” on the left handlebar.

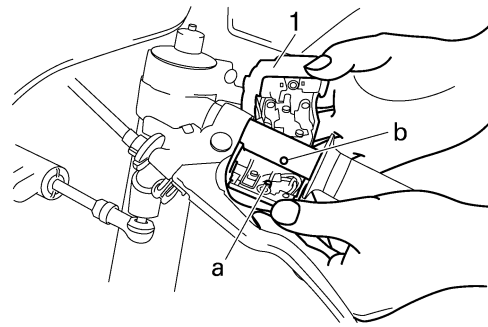

7. Install:

- Handlebar grip



- Apply a thin coat of rubber adhesive onto the end of the left handlebar.
- Slide the handlebar grip over the end of the left handlebar.
- Wipe off any excess rubber adhesive with a clean rag.

EWA13700

**WARNING**

**Do not touch the handlebar grip until the rubber adhesive has fully dried.**



8. Adjust:

- Clutch cable free play  
Refer to "ADJUSTING THE CLUTCH CABLE FREE PLAY" on page 3-14.



**Clutch lever free play**  
**10.0–15.0 mm (0.39–0.59 in)**

9. Adjust:

- Throttle cable free play  
Refer to "ADJUSTING THE THROTTLE CABLE FREE PLAY" on page 3-9.



**Throttle cable free play**  
**3.0–5.0 mm (0.12–0.20 in)**

EAS4C81004

**CHECKING THE STEERING DAMPER**

1. Check:

- Steering damper body  
Damage/oil leaks → Replace.  
(It replace with the assembly.)
- Steering damper rod  
Bends/scratch → Replace.  
(It replace with the assembly.)

## HANDLEBARS

---

- Bearing  
Damage/pitting → Replace.  
(It replace with the assembly.)

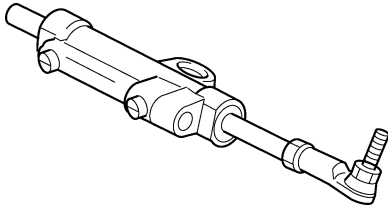

# FRONT FORK

EAS22950

## FRONT FORK

### Removing the front fork legs

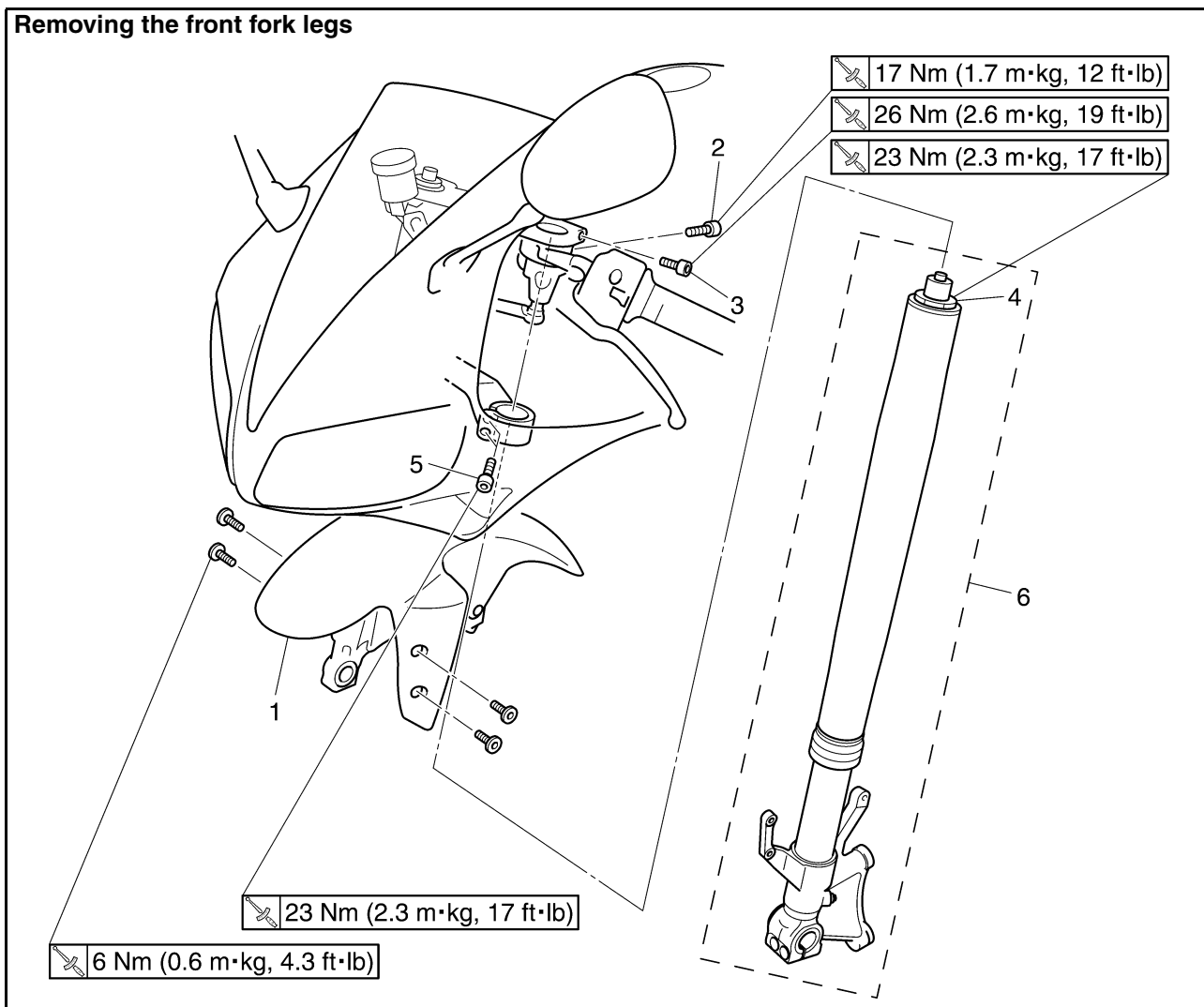

Order	Job/Parts to remove	Q'ty	Remarks
	Front wheel		Refer to "FRONT WHEEL" on page 4-8.
	Front brake caliper		Refer to "FRONT BRAKE" on page 4-20.
	Side cowling		Refer to "GENERAL CHASSIS" on page 4-1.
1	Front fender	1	
2	Handlebar pinch bolt	1	Loosen.
3	Upper bracket pinch bolt	1	Loosen.
4	Cap bolt	1	Loosen.
5	Lower bracket pinch bolt	1	Loosen.
6	Front fork leg	1	
			For installation, reverse the removal procedure.

# FRONT FORK

## Disassembling the front fork legs

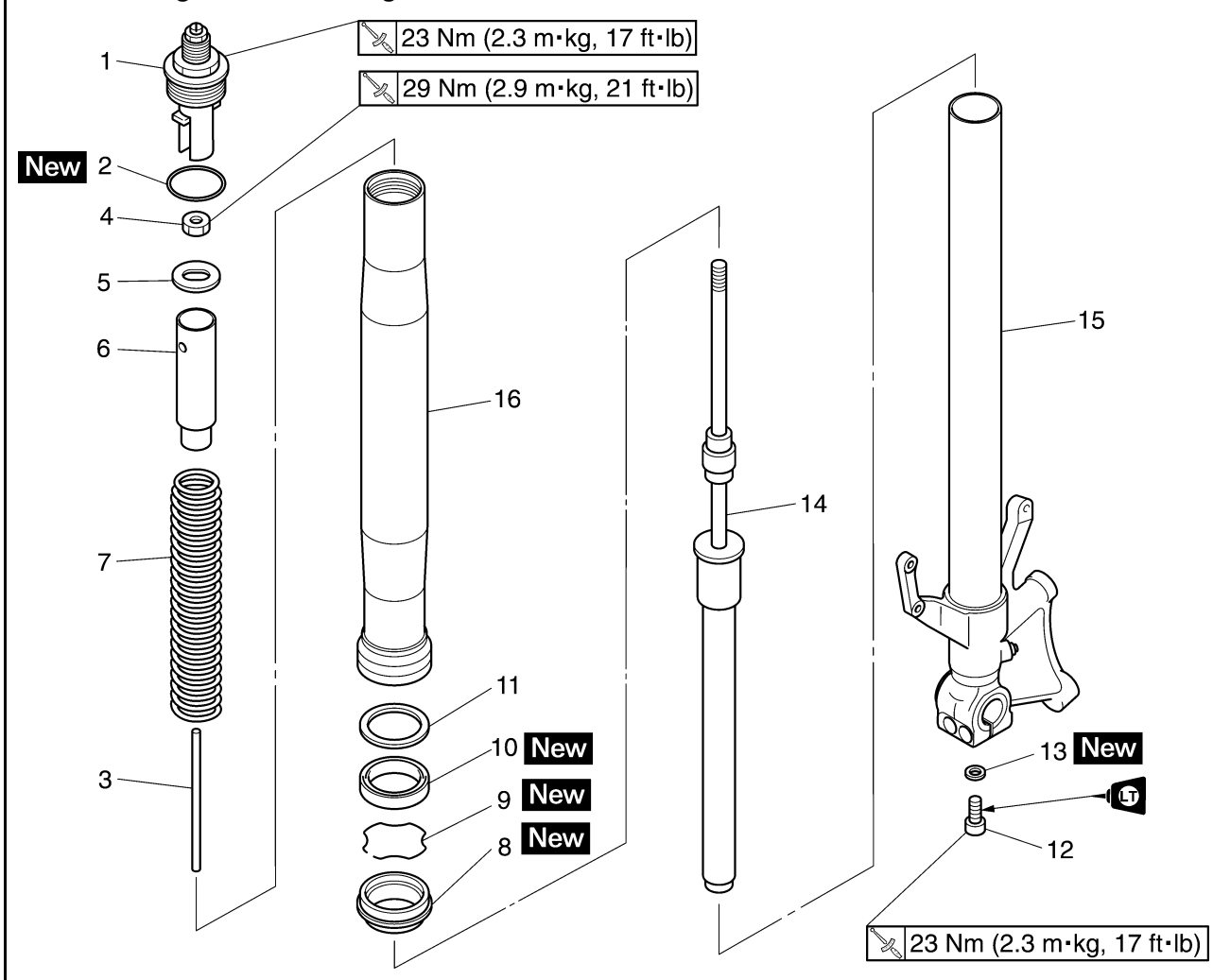

Order	Job/Parts to remove	Q'ty	Remarks
1	Cap bolt	1	
2	O-ring	1	
3	Damper adjusting rod	1	
4	Damper adjusting rod locknut	1	
5	Washer	1	
6	Spacer	1	
7	Fork spring	1	
8	Dust seal	1	
9	Oil seal clip	1	
10	Oil seal	1	
11	Washer	1	
12	Damper rod assembly bolt	1	
13	Copper washer	1	
14	Damper rod assembly	1	
15	Inner tube	1	
16	Outer tube	1	
			For assembly, reverse the disassembly procedure.

# FRONT FORK

EAS22970

## REMOVING THE FRONT FORK LEGS

The following procedure applies to both of the front fork legs.

1. Stand the vehicle on a level surface.

EWA13120

### WARNING

**Securely support the vehicle so that there is no danger of it falling over.**

### NOTE:

Place the vehicle on a suitable stand so that the front wheel is elevated.

2. Remove:

- Front wheel  
Refer to "FRONT WHEEL" on page 4-8.
- Front brake caliper  
Refer to "FRONT BRAKE" on page 4-20.
- Side cowlings  
Refer to "GENERAL CHASSIS" on page 4-1.

3. Loosen:

- Handlebar pinch bolt "1"
- Upper bracket pinch bolts "2"
- Cap bolt "3"
- Lower bracket pinch bolts "4"

EWA13640

### WARNING

**Before loosening the upper and lower bracket pinch bolts, support the front fork leg.**

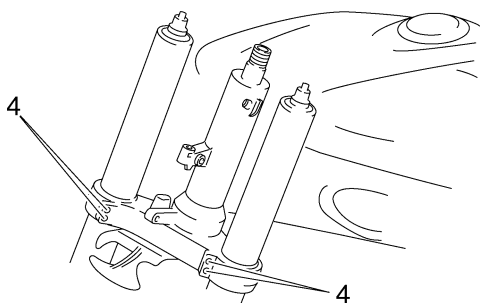
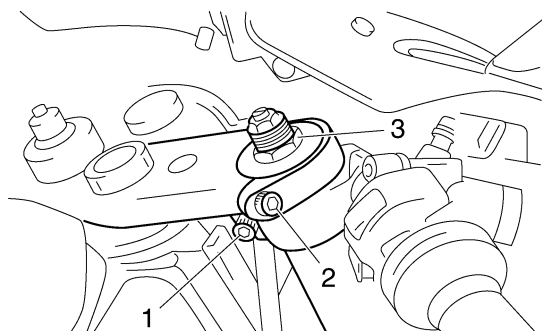

4. Remove:

- Front fork leg

EAS22990

## DISASSEMBLING THE FRONT FORK LEGS

The following procedure applies to both of the front fork legs.

1. Remove:

- Cap bolt "1"  
(from the damper adjusting rod)
- Spacers "2"
- Nut "3"



- a. Press down on the spacer with the fork spring compressor "4".
- b. Install the rod holder "5" between the nut "3" and the spacer "2".



**Fork spring compressor**

**90890-01441**

**YM-01441**

**Rod holder**

**90890-01434**

**Damper rod holder double ended**

**YM-01434**

### NOTE:

Use the side of the rod holder that is marked "A".

- c. Hold the spring preload adjusting bolt "6" and loosen the nut "3".

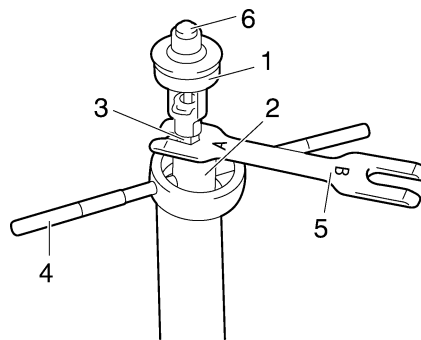

- d. Remove the cap bolt.
- e. Remove the rod holder and fork spring compressor.
- f. Remove the spacer and nut.



2. Drain:

- Fork oil

### NOTE:

Stroke the damper rod "1" several times while draining the fork oil.

# FRONT FORK

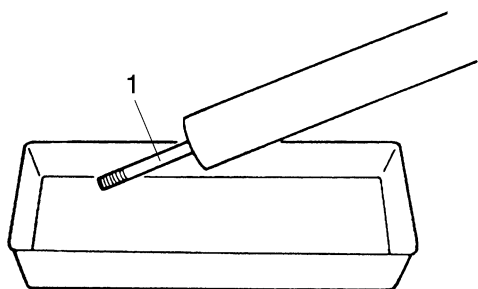

3. Remove:
- Dust seal
  - Oil seal clip "1" (with a flat-head screwdriver)
  - Oil seal
  - Washer

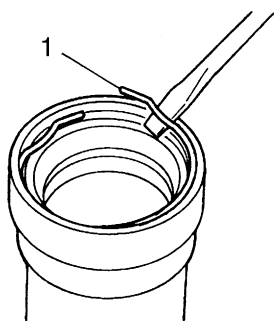

4. Remove:
- Damper rod assembly bolt
  - Damper rod assembly

**NOTE:** While holding the damper rod with the damper rod holder "1", loosen the damper rod assembly bolt.

	<b>Damper rod holder</b> 90890-01423
	<b>Damping rod holder</b> YM-01423

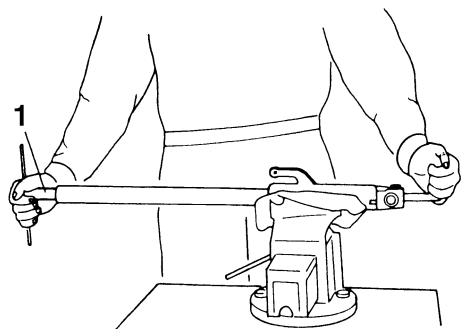

EAS23010  
**CHECKING THE FRONT FORK LEGS**  
 The following procedure applies to both of the front fork legs.

1. Check:
- Inner tube "1"
  - Outer tube "2"
- Bends/damage/scratches → Replace.

EWA13650

**WARNING**

**Do not attempt to straighten a bent inner tube as this may dangerously weaken it.**

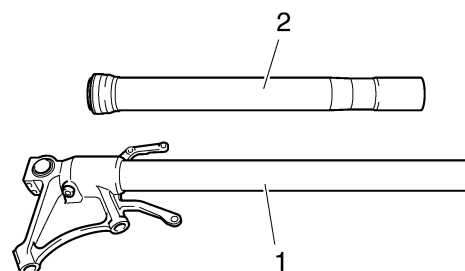

2. Measure:
- Spring free length "a"
- Out of specification → Replace.

	<b>Fork spring free length</b> 237.5 mm (9.35 in)
	<b>Limit</b> 232.8 mm (9.17 in)

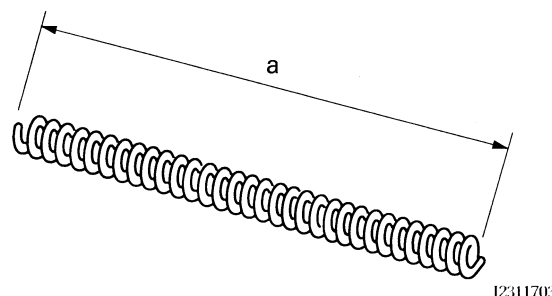

12311703

3. Check:
- Damper rod assembly "1"
- Damage/wear → Replace.  
 Obstruction → Blow out all of the oil passages with compressed air.
- Damper adjusting rod
- Bends/damage → Replace.

ECA14200

**CAUTION:**

- The front fork leg has a built-in damper adjusting rod and a very sophisticated internal construction, which are particularly sensitive to foreign material.
- When disassembling and assembling the front fork leg, do not allow any foreign material to enter the front fork.

# FRONT FORK

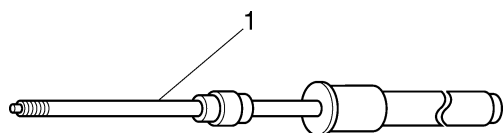

4. Check:

- Cap bolt O-ring "1"  
Damage/wear → Replace.

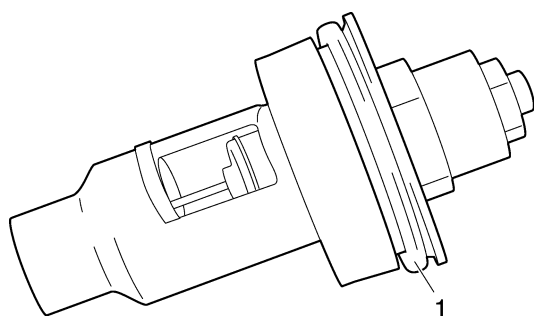

EAS23040

### ASSEMBLING THE FRONT FORK LEGS

The following procedure applies to both of the front fork legs.

EWA13660

**WARNING**

- Make sure the oil levels in both front fork legs are equal.
- Uneven oil levels can result in poor handling and a loss of stability.

**NOTE:**

- When assembling the front fork leg, be sure to replace the following parts:
  - Outer tube bushing
  - Oil seal
  - Dust seal
- Before assembling the front fork leg, make sure all of the components are clean.

1. Install:

- Damper rod assembly "1"
- Inner tube "2"
- Damper rod assembly bolt
- Cooper washer **New**

EWA4C81002

**WARNING**

Always use new copper washer.

ECA14210

**CAUTION:**

Allow the damper rod assembly to slide slowly down the inner tube "2" until it protrudes from the bottom of the inner tube. Be careful not to damage the inner tube.

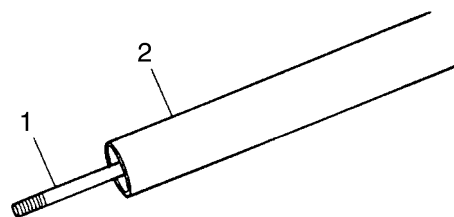

2. Lubricate:

- Inner tube's outer surface

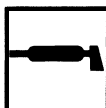

**Recommended oil**  
Suspension oil 01 or equivalent

3. Tighten:

- Damper rod assembly bolt "1"

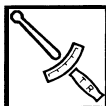

**Damper rod assembly bolt**  
23 Nm (2.3 m.kg, 17 ft.-lb)  
LOCTITE®

**NOTE:**

While holding the damper rod assembly with the damper rod holder "2", tighten the damper rod assembly bolt.



**Damper rod holder**  
90890-01423  
**Damping rod holder**  
YM-01423

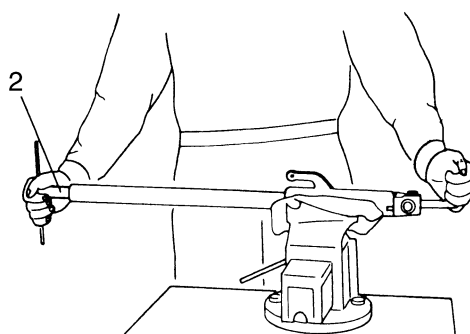
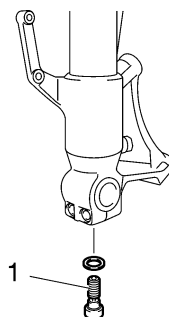

4. Install:

- Dust seal "1"

## FRONT FORK

- Oil seal clip “2”
- Oil seal “3”
- Washer “4”

ECA14220

**CAUTION:**

**Make sure the numbered side of the oil seal faces up.**

**NOTE:**

- Before installing the oil seal, lubricate its lips with lithium-soap-based grease.
- Lubricate the outer surface of the inner tube with fork oil.
- Before installing the oil seal, cover the top of the front fork leg with a plastic bag to protect the oil seal during installation.

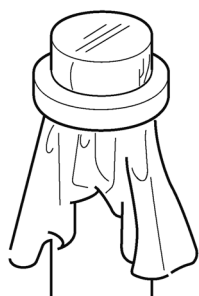
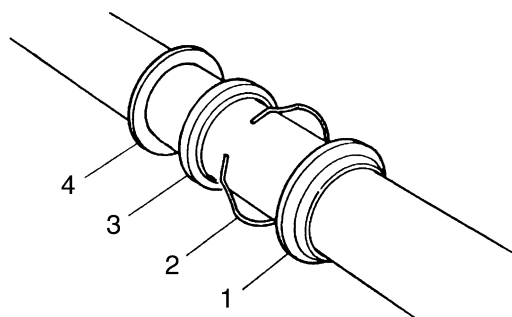

5. Install:
- Washer
  - Oil seal “1” (with the fork seal driver “2”)



**Fork seal driver  
90890-01442  
Adjustable fork seal driver (36–46 mm)  
YM-01442**

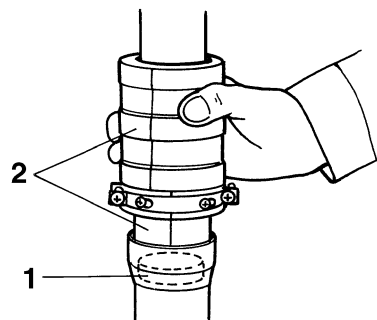

6. Install:
- Oil seal clip “1”

**NOTE:**

Adjust the oil seal clip so that it fits into the outer tube’s groove.

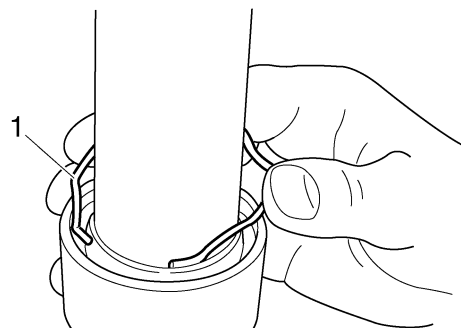

7. Install:
- Dust seal “1” (with the fork seal driver “2”)



**Fork seal driver  
90890-01442  
Adjustable fork seal driver (36–46 mm)  
YM-01442**

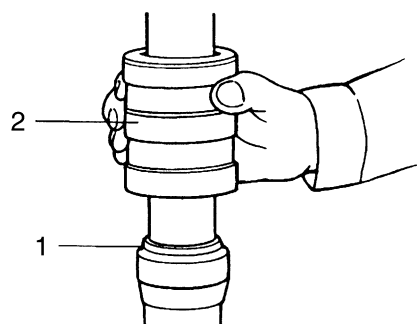

8. Install:
- Rod puller “1”
  - Rod puller attachment “2” (onto the damper rod “3”)

# FRONT FORK



**Rod puller**  
 90890-01437  
**Universal damping rod bleeding tool set**  
 YM-A8703  
**Rod puller attachment (M12)**  
 90890-01435  
**Universal damping rod bleeding tool set**  
 YM-A8703

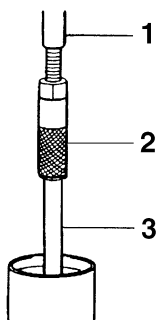

9. Fill:
- Front fork leg (with the specified amount of the recommended fork oil)



**Quantity**  
 513.0 cm<sup>3</sup> (17.34 US oz) (18.09 Imp.oz)  
**Recommended oil**  
 Suspension oil 01 or equivalent

ECA14230

**CAUTION:**

- Be sure to use the recommended fork oil. Other oils may have an adverse effect on front fork performance.
- When disassembling and assembling the front fork leg, do not allow any foreign material to enter the front fork.

10. After filling the front fork leg, slowly stroke the damper rod "1" up and down (at least ten times) to distribute the fork oil.

**NOTE:**

Be sure to stroke the damper rod slowly because the fork oil may spurt out.

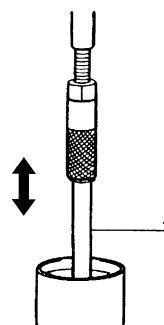

11. Before measuring the fork oil level, wait ten minutes until the oil has settled and the air bubbles have dispersed.

**NOTE:**

Be sure to bleed the front fork leg of any residual air.

12. Measure:

- Front fork leg oil level "a"
- Out of specification → Correct.



**Level**  
 101.0 mm (3.98 in)

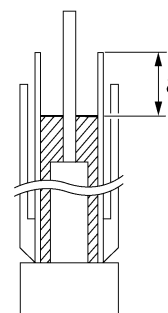

13. Install:

- Damper adjusting rod locknut "1"
- Fork spring "2"
- Spacer "3"
- Damper adjusting rod "4"
- Cap bolt "5"

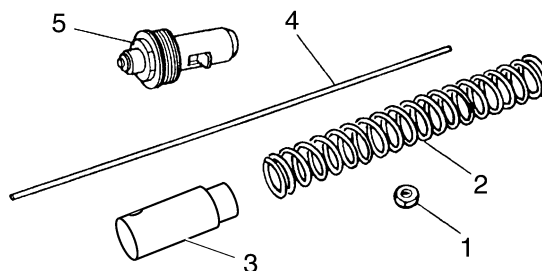

## FRONT FORK

- a. Remove the rod puller attachment.
- b. Install the nut.
- c. Install the fork spring and spacer.

**NOTE:**

Install the spring with the smaller pitch "a" facing up "A".

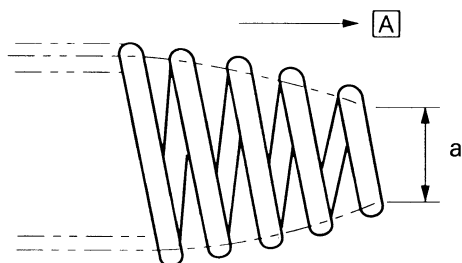

12311702

- d. Reinstall the rod puller attachment
- e. Press down in the spacer with the fork spring compressor "1"
- f. Pull up the rod puller and install the rod holder "2" between the damper adjusting rod locknut "3" and the spacer "4".

**NOTE:**

Use the side of the rod holder that is marked "A".



**Rod puller**  
90890-01437  
**Universal damping rod bleeding tool set**  
YM-A8703  
**Rod puller attachment (M12)**  
90890-01435  
**Universal damping rod bleeding tool set**  
YM-A8703  
**Fork spring compressor**  
90890-01441  
YM-01441  
**Rod holder**  
90890-01434  
**Damper rod holder double ended**  
YM-01434

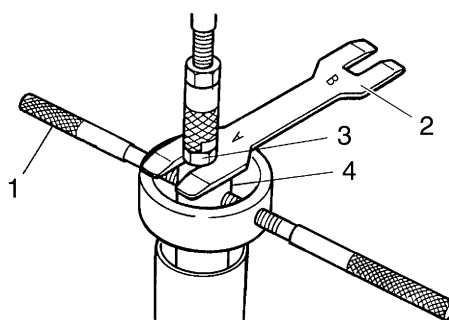

- g. Remove the rod puller and the rod puller attachment.
- h. Install the nut "1" and position it as specified "b".



**Distance "b"**  
11 mm (0.43 in)

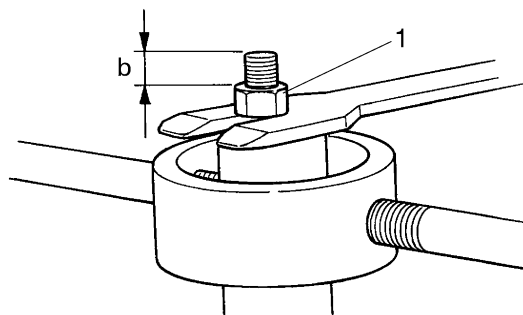

- i. Set the cap bolt distance "c" to specification.



**Distance "c"**  
13 mm (0.51 in)

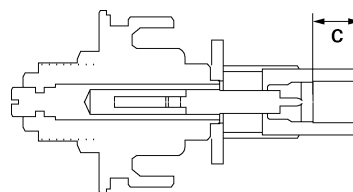

- j. Install the damper adjusting rod and cap bolt, and then finger tighten the cap bolt.
- k. Hold the cap bolt and tighten the damper adjusting rod locknut to specification.



**Damper adjusting rod locknut**  
29 Nm (2.9 m·kg, 21 ft·lb)

- l. Remove the rod holder and fork spring compressor.

# FRONT FORK

EWA4C81003

**⚠ WARNING**

- The fork spring is compressed.
- Always use a new cap bolt O-ring.



EAS23050

### INSTALLING THE FRONT FORK LEGS

The following procedure applies to both of the front fork legs.

1. Install:
  - Front fork leg  
Temporarily tighten the upper and lower bracket pinch bolts.
2. Tighten:
  - Lower bracket pinch bolt "1"

	<b>Lower bracket pinch bolt</b> 23 Nm (2.3 m·kg, 17 ft·lb)
---	---

- Cap bolt "2"

	<b>Cap bolt</b> 23 Nm (2.3 m·kg, 17 ft·lb)
--	---

- Handlebar pinch bolt "3"

	<b>Handlebar pinch bolt</b> 17 Nm (1.7 m·kg, 12 ft·lb)
---	---

- Upper bracket pinch bolt "4"

	<b>Upper bracket pinch bolt</b> 26 Nm (2.6 m·kg, 19 ft·lb)
---	---

EWA13680

**⚠ WARNING**

Make sure the brake hoses are routed properly.

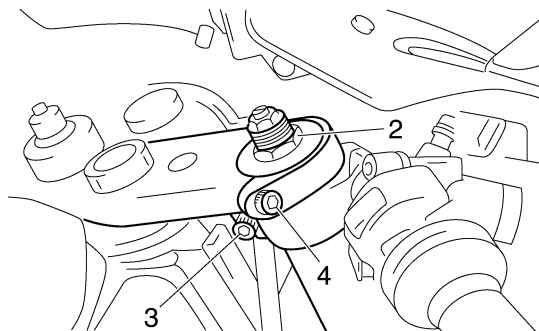

3. Adjust:
  - Spring preload
  - Rebound damping
  - Compression damping
 Refer to "ADJUSTING THE FRONT FORK LEGS" on page 3-30.

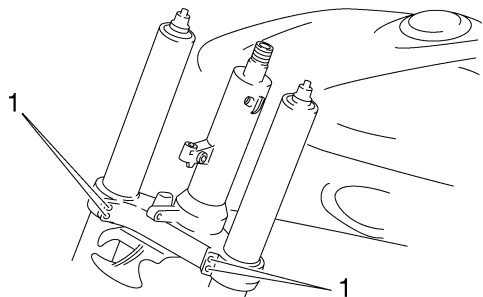

# STEERING HEAD

EAS23090

## STEERING HEAD

### Removing the lower bracket

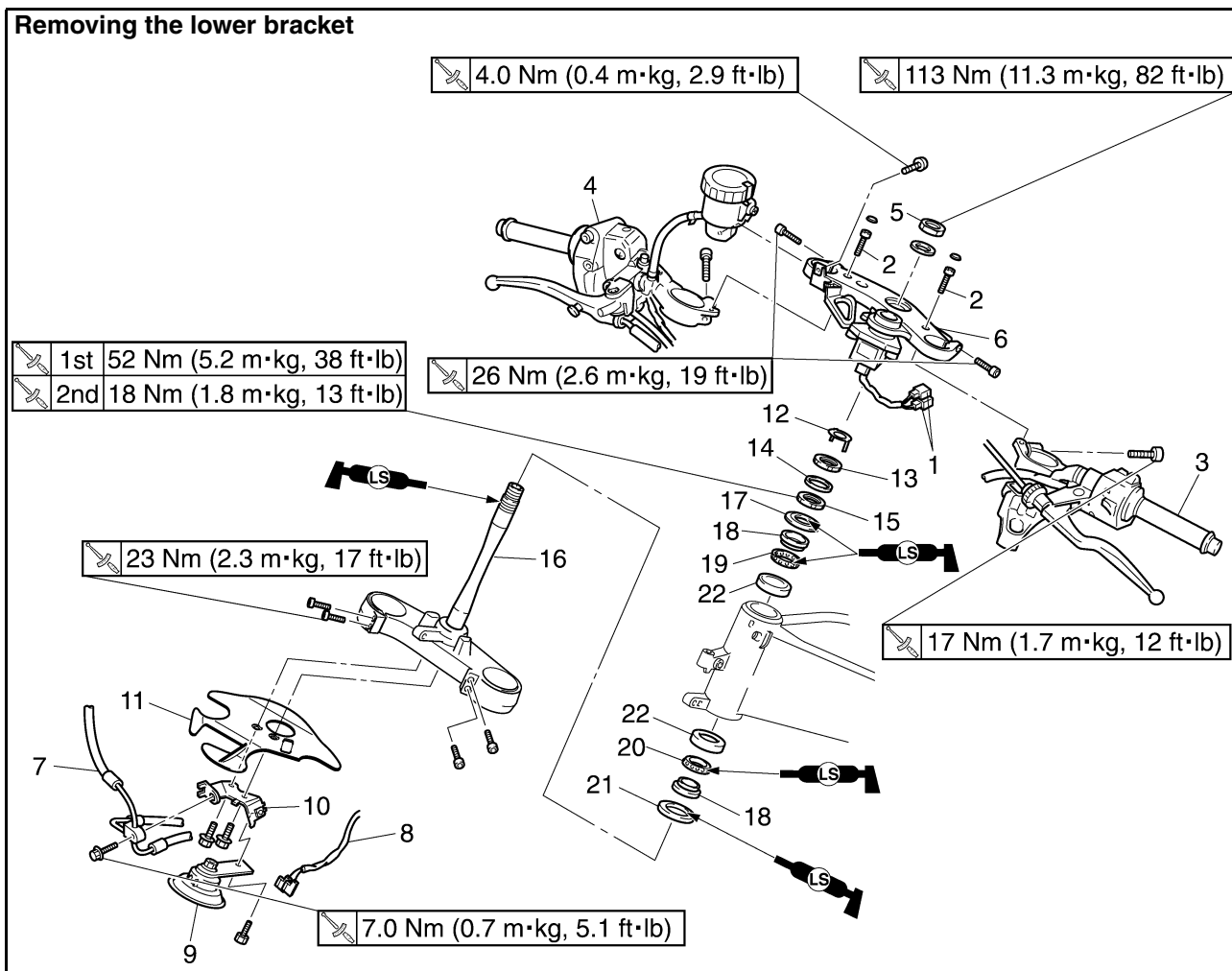

Order	Job/Parts to remove	Q'ty	Remarks
	Front cowling		Refer to "GENERAL CHASSIS" on page 4-1.
	Side cowling		Refer to "GENERAL CHASSIS" on page 4-1.
	Front wheel		Refer to "FRONT WHEEL" on page 4-8.
	Front fork legs		Refer to "FRONT BRAKE" on page 4-20.
	Handlebar		Refer to "HANDLEBARS" on page 4-45.
1	Main switch lead coupler	2	Disconnect.
2	Upper bracket bolt	2	
3	Left handlebar assembly	1	
4	Right handlebar assembly	1	
5	Steering stem nut	1	
6	Upper bracket	1	
7	Front brake hose joint	1	
8	Horn lead connector	1	Disconnect.
9	Horn	1	
10	Horn bracket	1	
11	Lower bracket cover	1	
12	Lock washer	1	
13	Upper ring nut	1	
14	Rubber washer	1	
15	Lower ring nut	1	
16	Lower bracket	1	

# STEERING HEAD

## Removing the lower bracket

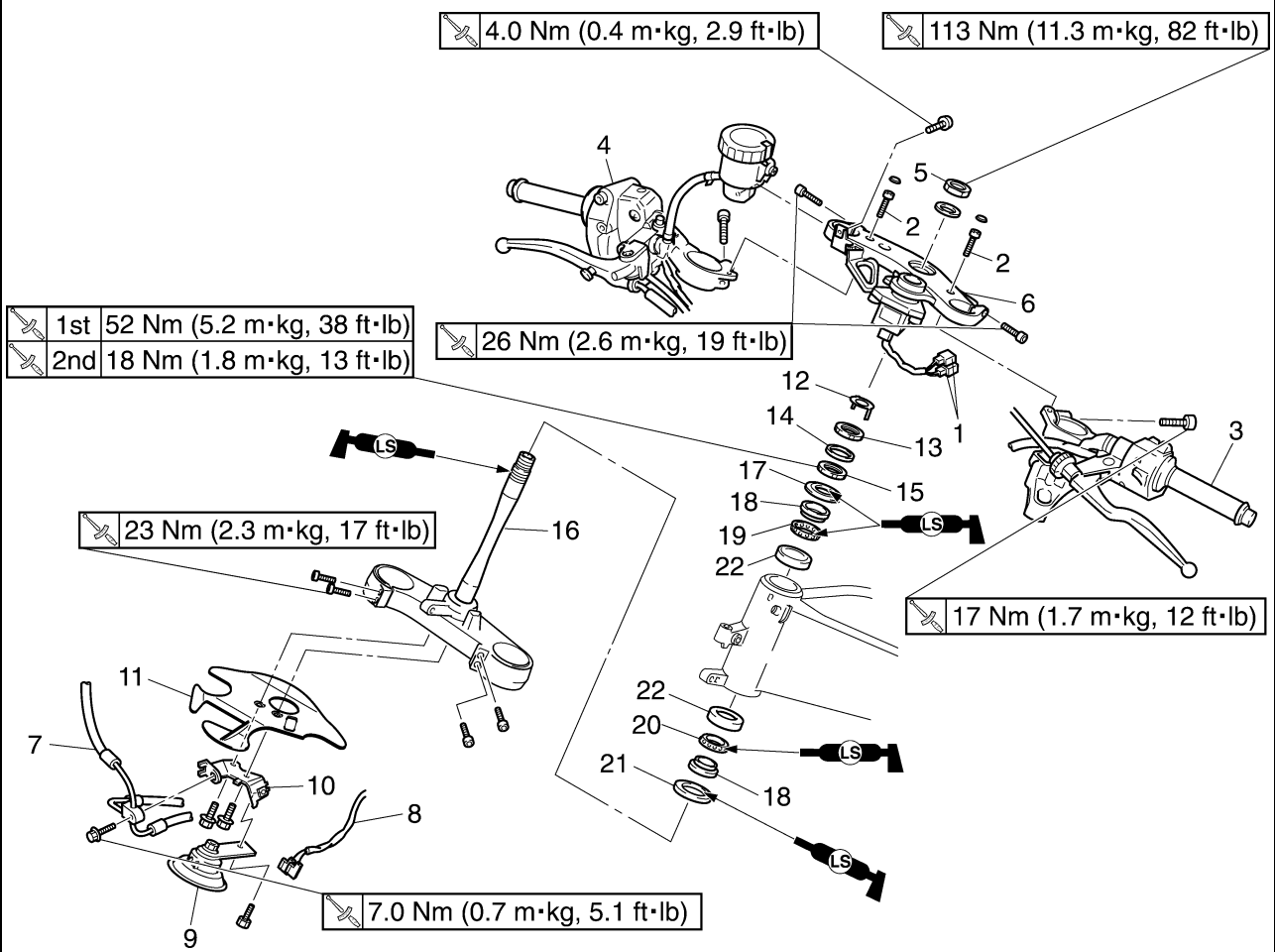

Order	Job/Parts to remove	Q'ty	Remarks
17	Bearing cover	1	
18	Bearing inner race	2	
19	Upper bearing	1	
20	Lower bearing	1	
21	Dust seal	1	
22	Bearing outer race	2	
			For installation, reverse the removal procedure.

## STEERING HEAD

EAS23110

### REMOVING THE LOWER BRACKET

1. Stand the vehicle on a level surface.

EWA13120

**WARNING**

Securely support the vehicle so that there is no danger of it falling over.

2. Remove:

- Upper ring nut "1"  
(with the steering nut wrench "2")



Steering nut wrench  
90890-01403  
Spanner wrench  
YU-33975

EWA13730

**WARNING**

Securely support the lower bracket so that there is no danger of it falling.

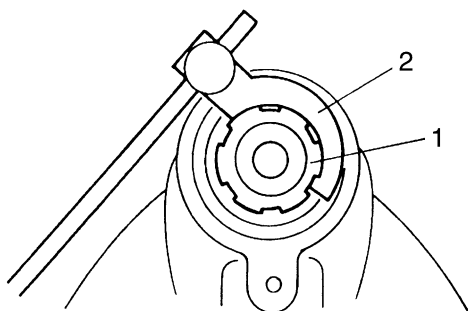

EAS23130

### CHECKING THE STEERING HEAD

1. Wash:

- Bearings
- Bearing races

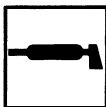

Recommended cleaning solvent  
Kerosene

2. Check:

- Bearings "1"
- Bearing races "2"  
Damage/pitting → Replace.

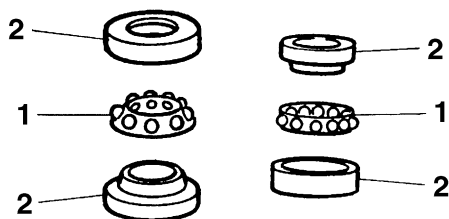

3. Replace:

- Bearings
- Bearing races



- Remove the bearing races "1" from the steering head pipe with a long rod "2" and hammer.
- Remove the bearing race "3" from the lower bracket with a floor chisel "4" and hammer.
- Install a new dust seal and new bearing races.

ECA14270

**CAUTION:**

If the bearing race is not installed properly, the steering head pipe could be damaged.

**NOTE:**

- Always replace the bearings and bearing races as a set.
- Whenever the steering head is disassembled, replace the rubber seal.

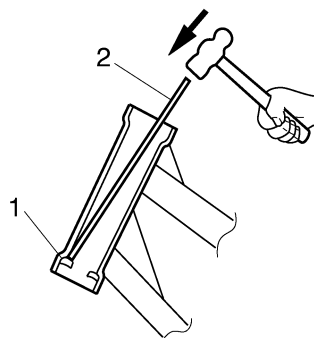

I2160503

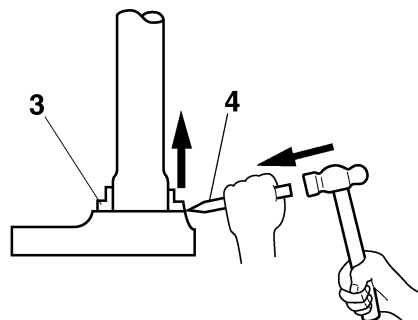

4. Check:

- Upper bracket
- Lower bracket  
(along with the steering stem)  
Bends/cracks/damage → Replace.

EAS23140

### INSTALLING THE STEERING HEAD

1. Lubricate:

- Upper bearing
- Lower bearing

## STEERING HEAD

- Bearing races



2. Install:

- Lower ring nut "1"
- Rubber washer "2"
- Upper ring nut "3"
- Lock washer "4"

Refer to "CHECKING AND ADJUSTING THE STEERING HEAD" on page 3-28.

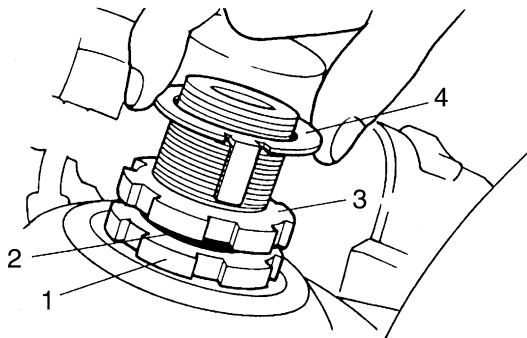

3. Install:

- Upper bracket
- Steering stem nut

**NOTE:** \_\_\_\_\_  
Temporarily tighten the steering stem nut.

4. Install:

- Front fork legs
- Refer to "INSTALLING THE FRONT FORK LEGS" on page 4-58.

**NOTE:** \_\_\_\_\_  
Temporarily tighten the upper and lower bracket pinch bolts.

## REAR SHOCK ABSORBER ASSEMBLY

EAS23160

### REAR SHOCK ABSORBER ASSEMBLY

#### Removing the rear shock absorber assembly

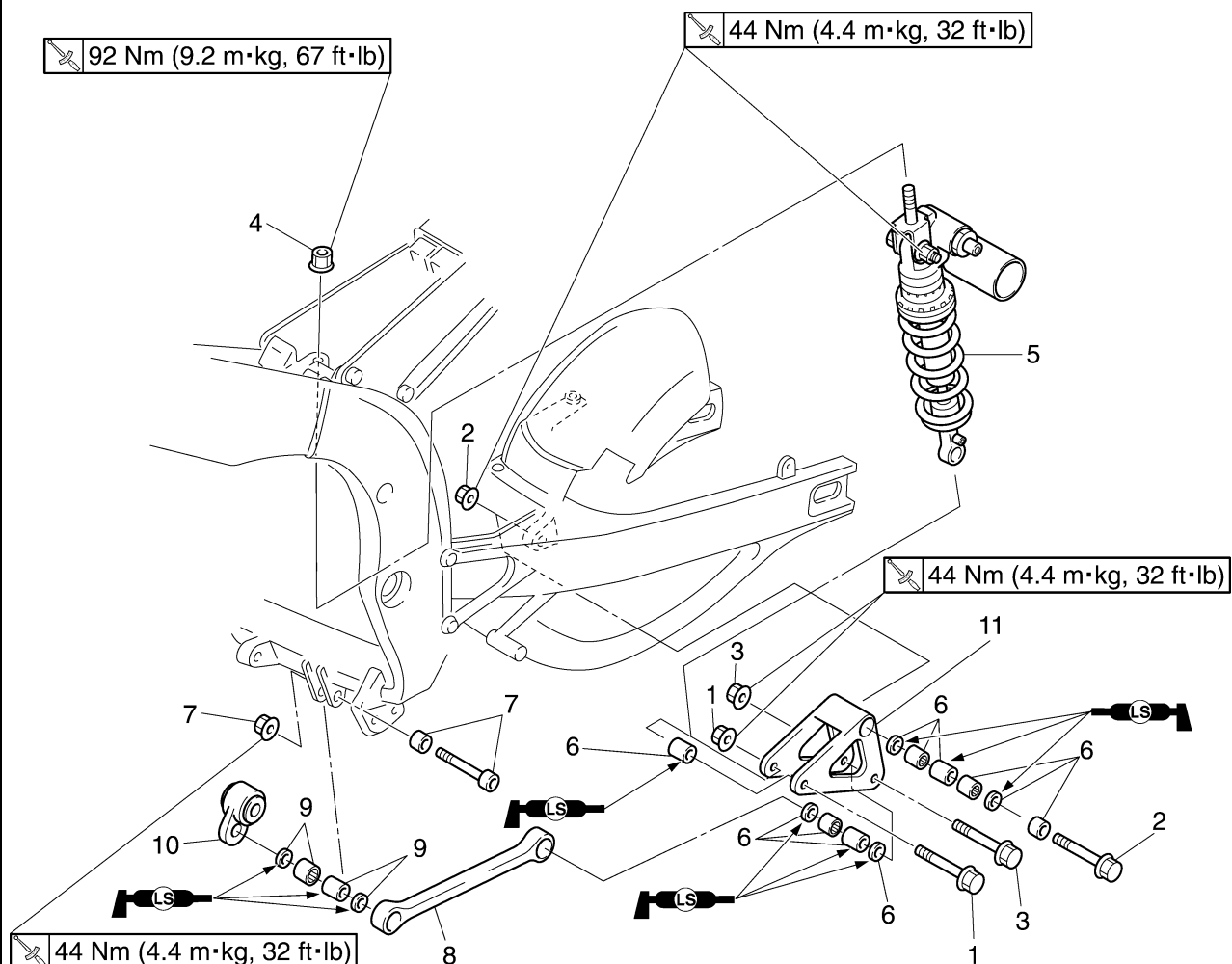

Order	Job/Parts to remove	Q'ty	Remarks
	Rider seat		Refer to "GENERAL CHASSIS" on page 4-1.
	Passenger seat		Refer to "GENERAL CHASSIS" on page 4-1.
	Fuel tank		Refer to "FUEL TANK" on page 7-1.
1	Self-locking nut/bolt	1/1	
2	Self-locking nut/bolt	1/1	
3	Self-locking nut/bolt	1/1/1	
4	Self-locking nut	1	
5	Rear shock absorber assembly	1	
6	Oil seal/bearing/collar	4/3/4	
7	Collar/self-locking nut/bolt	1/1/1	
8	Connecting arm	1	
9	Oil seal/bearing/collar	2/1/1	
10	Catalytic converter pipe stay	1	
11	Relay arm	1	
			For installation, reverse the removal procedure.

## REAR SHOCK ABSORBER ASSEMBLY

EAS23180

### HANDLING THE REAR SHOCK ABSORBER

EWA13740

#### WARNING

This rear shock absorber contains highly compressed nitrogen gas. Before handling the rear shock absorber, read and make sure you understand the following information. The manufacturer cannot be held responsible for property damage or personal injury that may result from improper handling of the rear shock absorber.

- Do not tamper or attempt to open the rear shock absorber.
- Do not subject the rear shock absorber to an open flame or any other source of high heat. High heat can cause an explosion due to excessive gas pressure.
- Do not deform or damage the rear shock absorber in any way. Rear shock absorber damage will result in poor damping performance.

EAS23190

### DISPOSING OF A REAR SHOCK ABSORBER

1. Gas pressure must be released before disposing of a rear shock absorber. To release the gas pressure, drill a 2–3-mm hole through the rear shock absorber at a point 15–20 mm from its end as shown.

EWA13760

#### WARNING

Wear eye protection to prevent eye damage from released gas or metal chips.

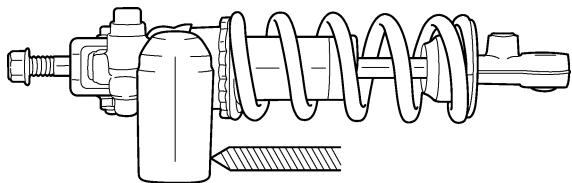

EAS23230

### REMOVING THE REAR SHOCK ABSORBER ASSEMBLY

1. Stand the vehicle on a level surface.

EWA13120

#### WARNING

Securely support the vehicle so that there is no danger of it falling over.

#### NOTE:

Place the vehicle on a suitable stand so that the rear wheel is elevated.

2. Remove:

- Rear shock absorber assembly lower bolt "1"
- Relay arm-to-swingarm bolt "2"

#### NOTE:

While removing the rear shock absorber assembly lower bolt, hold the swingarm so that it does not drop down.

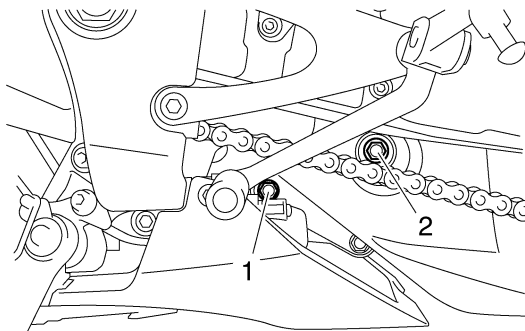

3. Remove:

- Rear shock absorber upper bracket nut "1"
- Rear shock absorber assembly

#### NOTE:

Lower the swingarm, and then remove the rear shock absorber assembly from between the swingarm and frame.

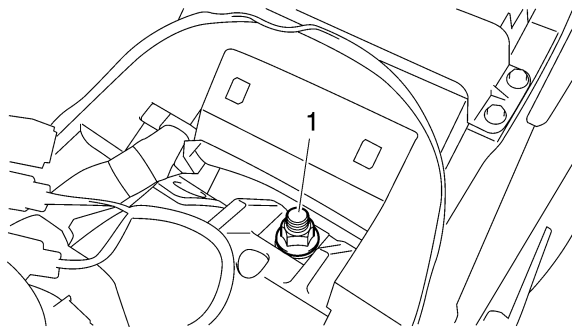

EAS23240

### CHECKING THE REAR SHOCK ABSORBER ASSEMBLY

1. Check:

- Rear shock absorber rod  
Bends/damage → Replace the rear shock absorber assembly.
- Rear shock absorber  
Gas leaks/oil leaks → Replace the rear shock absorber assembly.
- Spring  
Damage/wear → Replace the rear shock absorber assembly.
- Bushings  
Damage/wear → Replace.

## REAR SHOCK ABSORBER ASSEMBLY

- Dust seals  
Damage/wear → Replace.
- Bolts  
Bends/damage/wear → Replace.

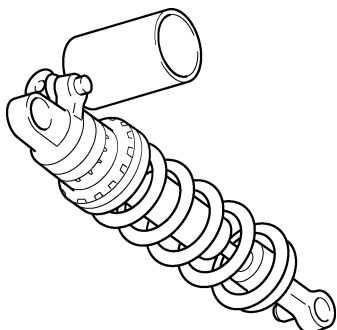

**Installed depth "a"**  
1.0 mm (0.04 in)  
**Installed depth "b"**  
4.0 mm (0.16 in)

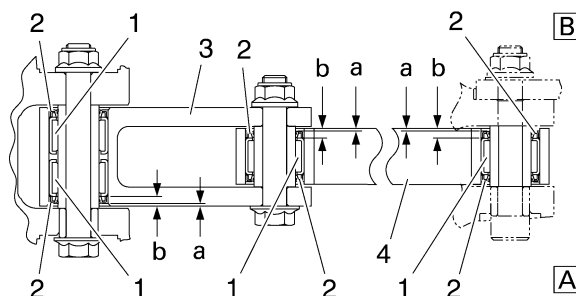

A. Left side  
B. Right side

EAS23260

### CHECKING THE CONNECTING ARM AND RELAY ARM

1. Check:
  - Connecting arm "1"
  - Relay arm "2"
  - Damage/wear → Replace.

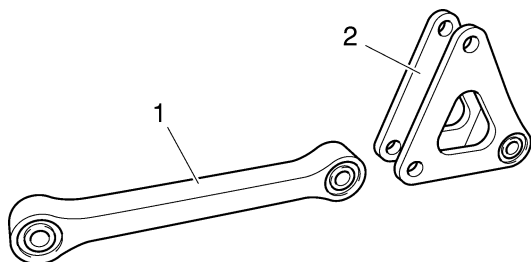

2. Check:
  - Bearings
  - Oil seals
  - Damage/pitting → Replace.
3. Check:
  - Collars
  - Damage/scratches → Replace.

EAS23270

### INSTALLING THE RELAY ARM

1. Lubricate:
  - Collars
  - Bearings

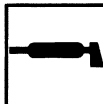

**Recommended lubricant**  
Lithium soap base grease

2. Install:
  - Bearing "1"
  - Oil seals "2"
  - (to the relay arm)
  - Relay arm "3"
  - Connecting arm "4"

EAS23310

### INSTALLING THE REAR SHOCK ABSORBER ASSEMBLY

1. Lubricate:
  - Collars
  - Bearings

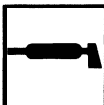

**Recommended lubricant**  
Molybdenum disulfide grease

2. Install:
  - Rear shock absorber assembly

#### NOTE:

Install the connecting arm front bolt from the left.

3. Tighten:
  - Rear shock absorber upper bracket nut



**Rear shock absorber upper bracket nut**  
92 Nm (9.2 m·kg, 67 ft·lb)

- Rear shock absorber assembly lower nut



**Rear shock absorber assembly lower nut**  
44 Nm (4.4 m·kg, 32 ft·lb)

- Relay-arm-to-swingarm nut



**Relay-arm-to-swingarm nut**  
44 Nm (4.4 m·kg, 32 ft·lb)

# SWINGARM

EAS23330

## SWINGARM

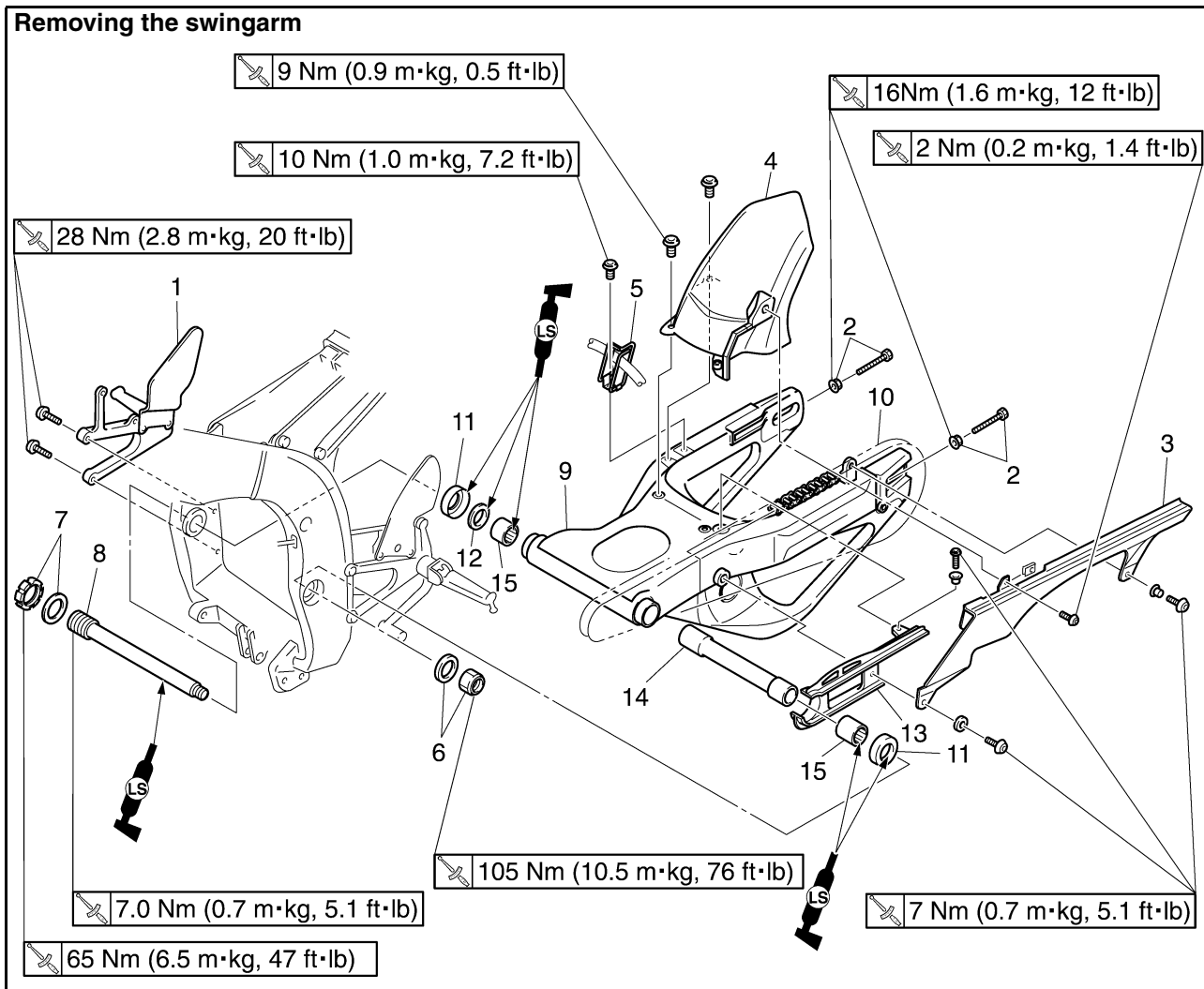

Order	Job/Parts to remove	Q'ty	Remarks
	Rear wheel		Refer to "REAR WHEEL" on page 4-14.
	Rear shock absorber assembly		Refer to "REAR SHOCK ABSORBER ASSEMBLY" on page 4-63.
	Drive sprocket		Refer to "ENGINE REMOVAL" on page 5-1.
1	Right footrest bracket	1	
2	Drive chain adjusting bolt/locknut	2/2	
3	Drive chain guard	1	
4	Rear fender	1	
5	Brake hose holder	1	
6	Pivot shaft nut/washer	1/1	
7	Pivot shaft ring nut/washer	1/1	
8	Pivot shaft	1	
9	Swingarm	1	
10	Drive chain	1	
11	Dust cover	2	
12	Washer	1	
13	Drive chain guide	1	
14	Spacer	1	
15	Bearing	2	

# SWINGARM

## Removing the swingarm

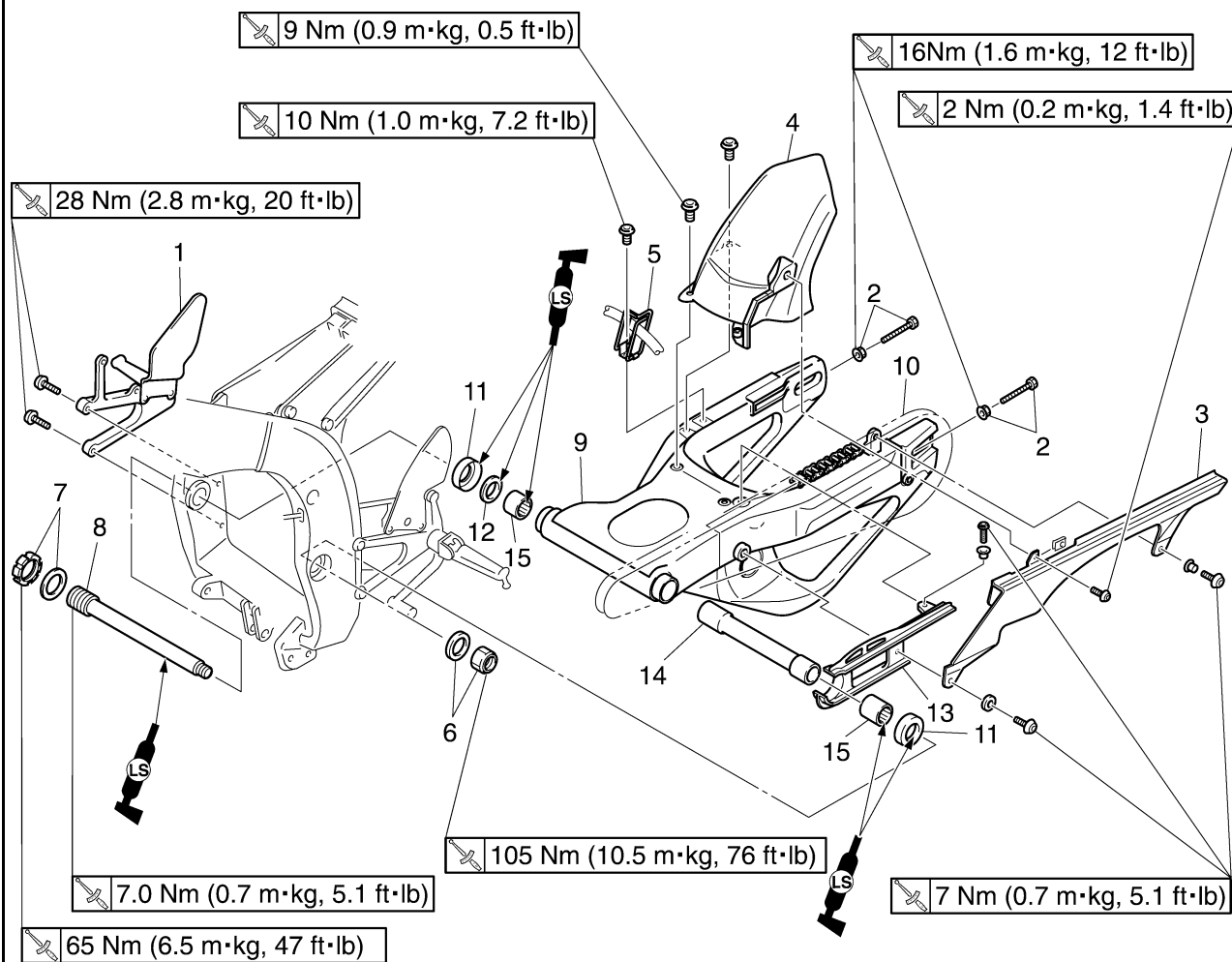

Order	Job/Parts to remove	Q'ty	Remarks
			For installation, reverse the removal procedure.

# SWINGARM

EAS23350

## REMOVING THE SWINGARM

1. Stand the vehicle on a level surface.

EWA13120

**⚠ WARNING**

**Securely support the vehicle so that there is no danger of it falling over.**

**NOTE:**

Place the vehicle on a suitable stand so that the rear wheel is elevated.

2. Remove:

- Relay arm-to-swingarm bolt "1"
- Connecting arm bolt "2"
- Rear shock absorber assembly lower bolt "3"

**NOTE:**

When removing the rear shock absorber assembly lower bolt, hold the swingarm so that it does not drop down.

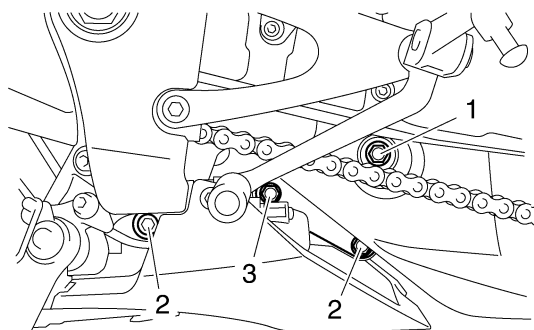

3. Measure:

- Swingarm side play
- Swingarm vertical movement

a. Measure the tightening torque of the pivot shaft nut, pivot shaft ring nut, and pivot shaft.

	<b>Pivot shaft nut</b>
	<b>105 Nm (10.5 m·kg, 76 ft·lb)</b>
	<b>Pivot shaft ring nut</b>
	<b>65 Nm (6.5 m·kg, 47 ft·lb)</b>
	<b>Pivot shaft</b>
	<b>7 Nm (0.7 m·kg, 5.1 ft·lb)</b>

- b. Measure the swingarm side play "A" by moving the swingarm from side to side.
- c. If the swingarm side play is out of specification, check the spacers, bearings, washers, and dust covers.



**Swingarm side play (at the end of the swingarm)**  
**1.0 mm (0.04 in)**

- d. Check the swingarm vertical movement "B" by moving the swingarm up and down. If swingarm vertical movement is not smooth or if there is binding, check the spacers, bearings, washers, and dust covers.

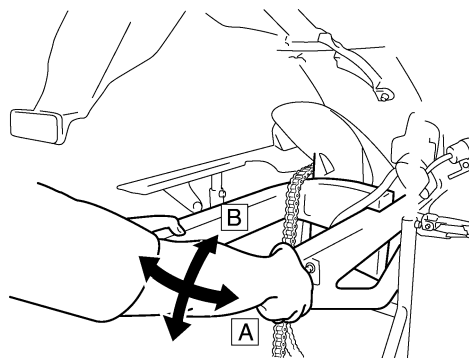

4. Remove:

- Drive chain  
Refer to "REMOVING THE DRIVE CHAIN" on page 4-72.

5. Remove:

- Pivot shaft nut
- Swingarm pivot shaft ring nut "1"

**NOTE:**

Loosen the swingarm pivot shaft ring nut with the ring nut wrench "2".



**Ring nut wrench**  
**90890-01507**  
**YM-01507**

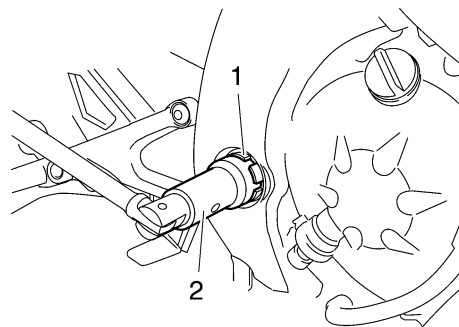

6. Remove:

- Swingarm pivot shaft "1"

# SWINGARM

**NOTE:**

Loosen the swingarm pivot shaft with the damper rod holder (22 mm) "2".



**Damper rod holder (22 mm)  
90890-01365**

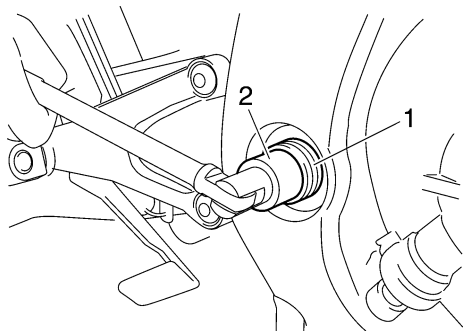

EAS23360

**CHECKING THE SWINGARM**

1. Check:

- Swingarm  
Bends/cracks/damage → Replace.

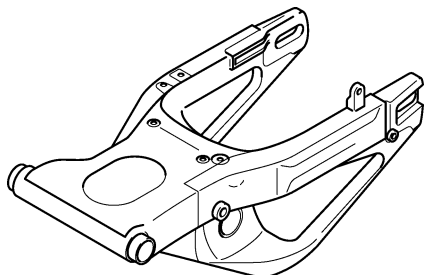

2. Check:

- Pivot shaft  
Roll the pivot shaft on a flat surface.  
Bends → Replace.

EWA13770

**WARNING**

**Do not attempt to straighten a bent pivot shaft.**

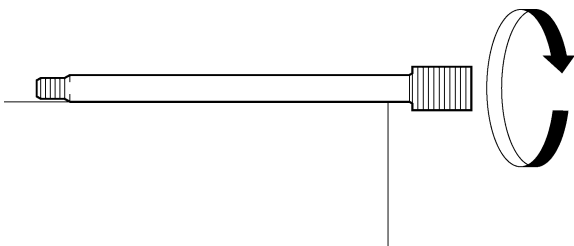

3. Wash:

- Pivot shaft
- Dust covers
- Spacer

- Washers
- Bearings

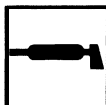

**Recommended cleaning solvent  
Kerosene**

4. Check:

- Dust covers "1"
- Spacer "2"
- Washer "3"  
Damage/wear → Replace.
- Bearings "4"  
Damage/pitting → Replace.

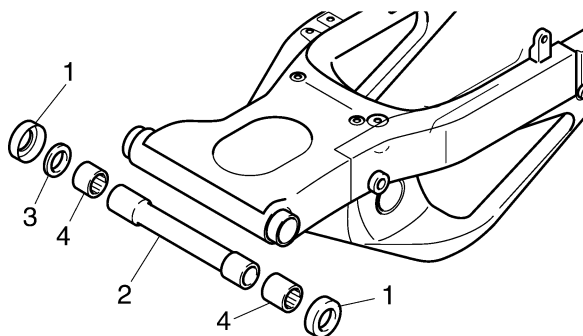

EAS23380

**INSTALLING THE SWINGARM**

1. Lubricate:

- Bearings
- Spacers
- Dust covers
- Pivot shaft

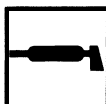

**Recommended lubricant  
Molybdenum disulfide grease**

2. Install:

- Bearing "1"
- Bearing "2"
- Washer "3"



**Installed depth of bearing "a"  
0–1.0 mm (0–0.04 in)**

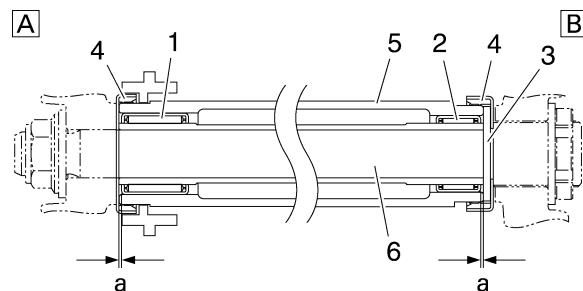

4. Dust cover

# SWINGARM

- 5. Swingarm
- 6. Pivot shaft
  - A. Left side
  - B. Right side
- 3. Install:
  - Pivot shaft "1"

	<p><b>Pivot shaft</b>  <b>7 Nm (0.7 m·kg, 5.1 ft·lb)</b></p>
---	--

**NOTE:**  
 Tighten the pivot shaft with the damper rod holder (22 mm) "2".

	<p><b>Damper rod holder (22 mm)</b>  <b>90890-01365</b></p>
---	---

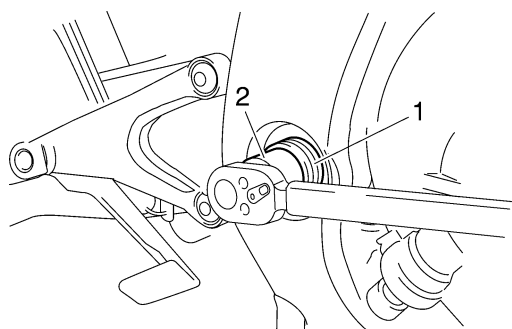

- 4. Install:
  - Pivot shaft ring nut "1"

	<p><b>Pivot shaft ring nut</b>  <b>65 Nm (6.5 m·kg, 47 ft·lb)</b></p>
---	---

**NOTE:**

- Lubricate the pivot ring nut threads and mating surfaces with lithium-soap-based grease.
- Tighten the pivot shaft ring nut with the ring nut wrench "2".

	<p><b>Ring nut wrench</b>  <b>90890-01507</b>  <b>YM-01507</b></p>
---	--

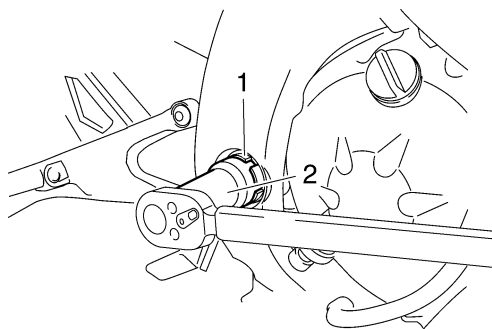

- 5. Install:
  - Pivot shaft nut "1"

	<p><b>Pivot shaft nut</b>  <b>105 Nm (10.5 m·kg, 76 ft·lb)</b></p>
---	--

**NOTE:**  
 Lubricant the pivot shaft nut threads and mating surfaces with lithium-soap-based grease.

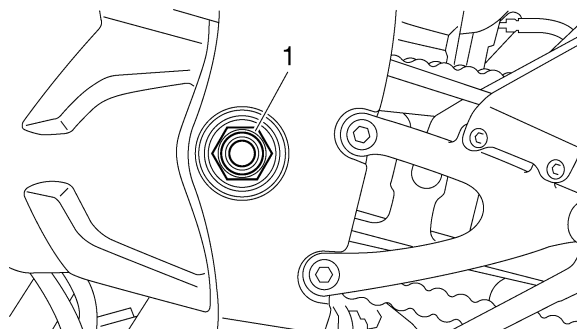

- 6. Adjust:
  - Drive chain slack  
 Refer to "ADJUSTING THE DRIVE CHAIN SLACK" on page 3-27.

	<p><b>Drive chain slack</b>  <b>30.0–40.0 mm (1.18–1.57 in)</b></p>
---	---

# CHAIN DRIVE

EAS23400

## CHAIN DRIVE

### Removing the drive chain

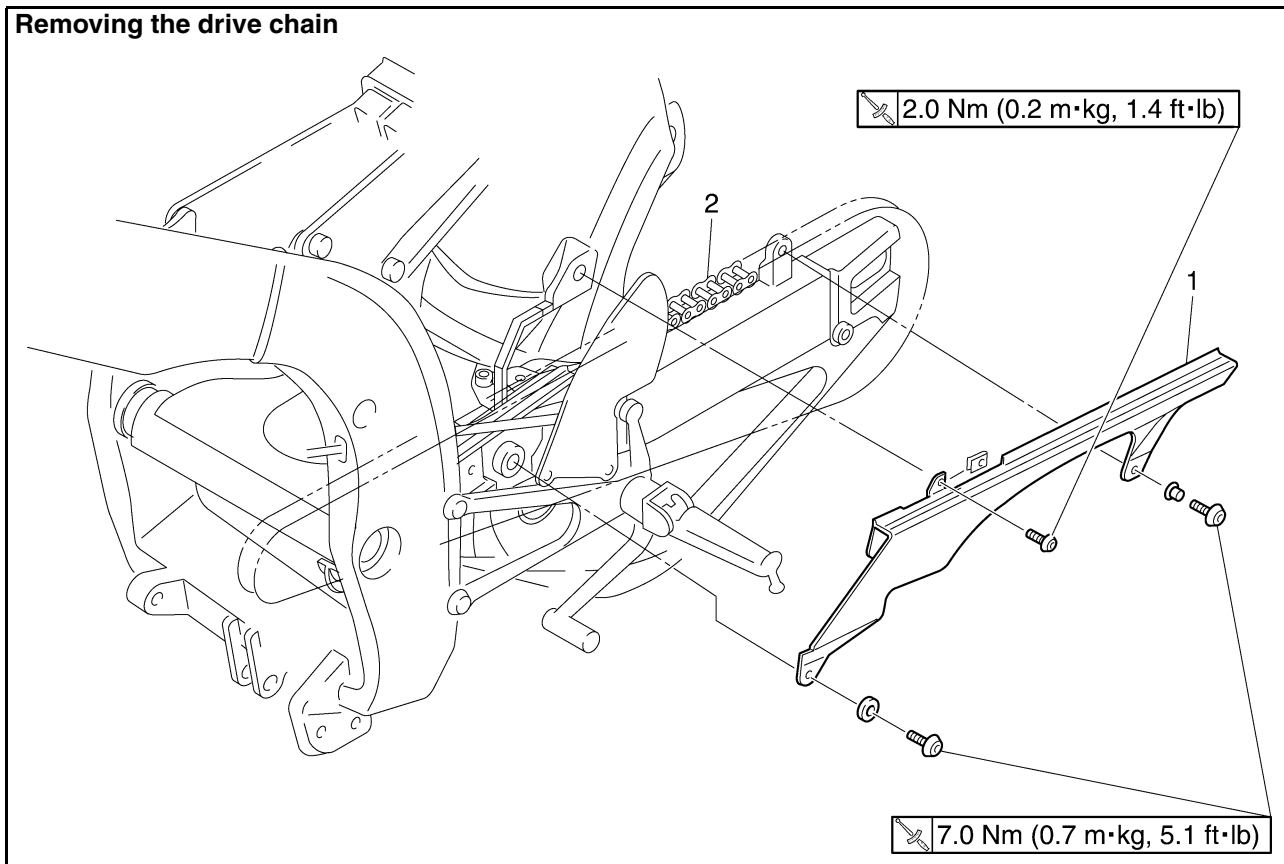

Order	Job/Parts to remove	Q'ty	Remarks
	Swingarm		Refer to "SWINGARM" on page 4-66.
1	Drive chain guard	1	
2	Drive chain	1	
			For installation, reverse the removal procedure.

# CHAIN DRIVE

EAS23410

## REMOVING THE DRIVE CHAIN

1. Stand the vehicle on a level surface.

EWA13120



**WARNING**

**Securely support the vehicle so that there is no danger of it falling over.**

### NOTE:

Place the vehicle on a suitable stand so that the rear wheel is elevated.

2. Remove:

- Drive chain  
(with the drive chain cutter)

EAS23440

## CHECKING THE DRIVE CHAIN

1. Measure:

- Measure the dimension between 15-links on the inner side "a" and outer side "b" of the roller and calculate the dimension between pin centers.
- Dimension "c" between pin centers = (Inner dimension "a" + Outer dimension "b")/2
- 15-link section "c" of the drive chain  
Out of specification → Replace the drive chain, front drive sprocket and rear drive sprocket as a set.



**15-link length limit**  
**239.3 mm (9.42 in)**

### NOTE:

- While measuring the 15-link section, push down on the drive chain to increase its tension.
- Perform this measurement at two or three different places.

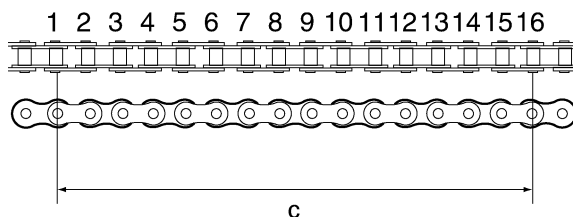
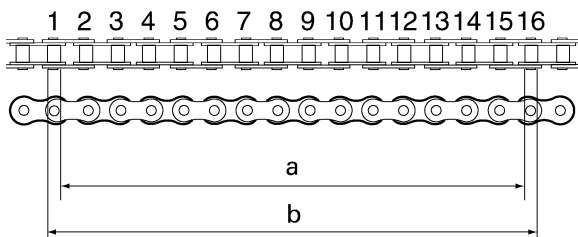

2. Check:

- Drive chain  
Stiffness → Clean and lubricate or replace.

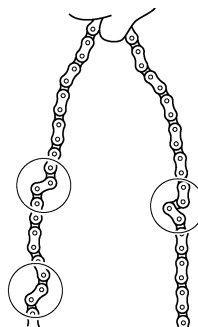

12510204

3. Clean:

- Drive chain



- Wipe the drive chain with a clean cloth.
- Put the drive chain in kerosene and remove any remaining dirt.
- Remove the drive chain from the kerosene and completely dry it.

ECA4C81003

### CAUTION:

- **This vehicle has a drive chain with small rubber O-rings "1" between the drive chain side plates. Never use high-pressure water or air, steam, gasoline, certain solvents (e.g., benzine), or a coarse brush to clean the drive chain. High-pressure methods could force dirt or water into the drive chain's internals, and solvents will deteriorate the O-rings. A coarse brush can also damage the O-rings. Therefore, use only kerosene to clean the drive chain.**
- **Do not soak the drive chain in kerosene for more than ten minutes, otherwise the O-rings can be damaged.**

# CHAIN DRIVE

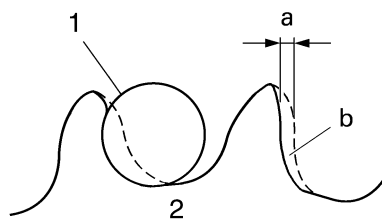
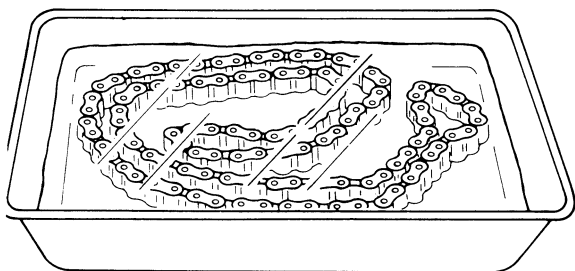

- b. Correct
- 1. Drive chain roller
- 2. Drive chain sprocket

EAS23470

### CHECKING THE REAR WHEEL SPROCKET

Refer to "CHECKING AND REPLACING THE REAR WHEEL SPROCKET" on page 4-18

EAS23480

### CHECKING THE REAR WHEEL DRIVE HUB

Refer to "CHECKING THE REAR WHEEL DRIVE HUB" on page 4-18

EAS23490

### INSTALLING THE DRIVE CHAIN

1. Lubricate:
  - Drive chain

	<b>Recommended lubricant</b> <b>Engine oil or chain lubricant</b> <b>suitable for O-ring chains</b>
--	---

2. Install:
  - Drive chain "1"
  - Drive sprocket "2"
  - Washer
  - Drive sprocket nut "3"

	<b>Drive sprocket nut</b> <b>100 Nm (10 m.kg, 72 ft.lb)</b>
--	--

**NOTE:**  
While applying the rear brake, tighten the drive sprocket nut.

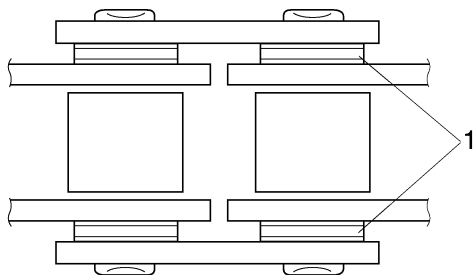

I2510201



4. Check:
  - O-rings "1"  
Damage → Replace the drive chain.
  - Drive chain rollers "2"  
Damage/wear → Replace the drive chain.
  - Drive chain side plates "3"  
Damage/wear/cracks → Replace the drive chain.

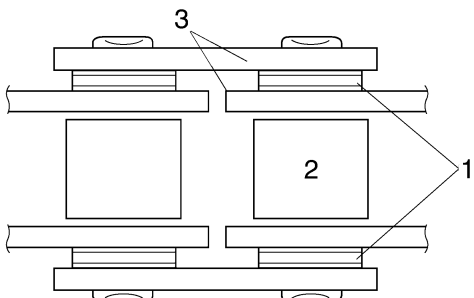

I2510201

5. Lubricate:
  - Drive chain

	<b>Recommended lubricant</b> <b>Engine oil or chain lubricant</b> <b>suitable for O-ring chains</b>
--	---

6. Check:
  - Drive sprocket
  - Rear wheel sprocket  
More than 1/4 tooth "a" wear → Replace the drive chain sprockets as a set.  
Bent teeth → Replace the drive chain sprockets as a set.

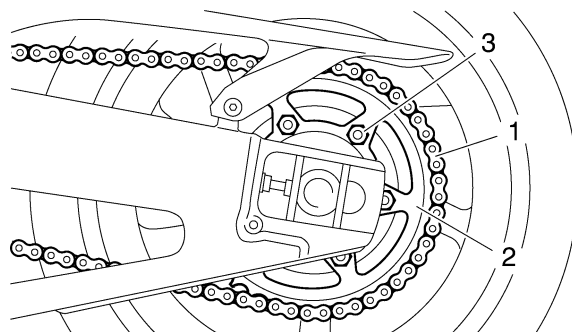

## CHAIN DRIVE

---

ECA14300

**CAUTION:**

**Never install a new drive chain onto worn drive chain sprockets; this will dramatically shorten the drive chain's life.**

---

3. Adjust:

- Drive chain slack

Refer to "ADJUSTING THE DRIVE CHAIN SLACK" on page 3-27



**Drive chain slack**  
**30.0–40.0 mm (1.18–1.57 in)**

ECA13550

**CAUTION:**

**A drive chain that is too tight will overload the engine and other vital parts, and one that is too loose can skip and damage the swingarm or cause an accident. Therefore, keep the drive chain slack within the specified limits.**

---

## **CHAIN DRIVE**

---

---

## ENGINE

<b>ENGINE REMOVAL</b> .....	5-1
INSTALLING THE ENGINE .....	5-7
<b>CAMSHAFTS</b> .....	5-9
REMOVING THE CAMSHAFTS .....	5-11
CHECKING THE CAMSHAFTS .....	5-12
CHECKING THE TIMING CHAIN AND CAMSHAFT SPROCKET .....	5-13
CHECKING THE TIMING CHAIN GUIDES .....	5-13
CHECKING THE TIMING CHAIN TENSIONER .....	5-13
INSTALLING THE CAMSHAFTS .....	5-15
<b>CYLINDER HEAD</b> .....	5-18
REMOVING THE CYLINDER HEAD .....	5-19
CHECKING THE CYLINDER HEAD .....	5-19
INSTALLING THE CYLINDER HEAD .....	5-19
<b>VALVES AND VALVE SPRINGS</b> .....	5-21
REMOVING THE VALVES .....	5-23
CHECKING THE VALVES AND VALVE GUIDES .....	5-23
CHECKING THE VALVE SEATS .....	5-25
CHECKING THE VALVE SPRINGS.....	5-27
CHECKING THE VALVE LIFTERS .....	5-28
INSTALLING THE VALVES.....	5-28
<b>GENERATOR</b> .....	5-30
REMOVING THE GENERATOR .....	5-32
INSTALLING THE GENERATOR.....	5-32
<b>STARTER CLUTCH</b> .....	5-34
REMOVING THE STARTER CLUTCH .....	5-35
CHECKING THE DAMPER .....	5-35
CHECKING THE STARTER CLUTCH.....	5-35
INSTALLING THE STARTER CLUTCH .....	5-36
<b>CRANKSHAFT POSITION SENSOR</b> .....	5-37
REMOVING THE CRANKSHAFT POSITION SENSOR .....	5-38
INSTALLING THE CRANKSHAFT POSITION SENSOR .....	5-38
<b>ELECTRIC STARTER</b> .....	5-39
CHECKING THE STARTER MOTOR .....	5-41
ASSEMBLING THE STARTER MOTOR.....	5-42
INSTALLING THE STARTER MOTOR.....	5-43
<b>CLUTCH</b> .....	5-44
REMOVING THE CLUTCH.....	5-47
CHECKING THE FRICTION PLATES .....	5-48

---

CHECKING THE CLUTCH PLATES.....	5-48
CHECKING THE CLUTCH SPRINGS.....	5-49
CHECKING THE CLUTCH HOUSING.....	5-49
CHECKING THE CLUTCH BOSS.....	5-49
CHECKING THE PRESSUR PLATE 2.....	5-50
CHECKING THE PRESSURE PLATE 1.....	5-50
CHECKING THE PUSH LEVER SHAFT AND PUSH ROD.....	5-50
INSTALLING THE CLUTCH.....	5-50
<b>SHIFT SHAFT.....</b>	<b>5-54</b>
REMOVING THE SHIFT SHAFT.....	5-55
CHECKING THE SHIFT SHAFT.....	5-55
CHECKING THE STOPPER LEVER.....	5-55
INSTALLING THE SHIFT SHAFT.....	5-55
<b>OIL PUMP.....</b>	<b>5-57</b>
REMOVING THE OIL PAN.....	5-60
CHECKING THE SPROCKET AND CHAIN.....	5-60
CHECKING THE OIL PUMP.....	5-60
CHECKING THE RELIEF VALVE.....	5-61
CHECKING THE OIL DELIVERY PIPES.....	5-61
CHECKING THE OIL STRAINER.....	5-61
CHECKING THE OIL NOZZLES.....	5-61
ASSEMBLING THE OIL PUMP.....	5-62
INSTALLING THE OIL/WATER PUMP ASSEMBLY.....	5-62
INSTALLING THE OIL PAN.....	5-63
<b>CRANKCASE.....</b>	<b>5-65</b>
DISASSEMBLING THE CRANKCASE.....	5-67
CHECKING THE CRANKCASE.....	5-67
CHECKING THE BEARING AND OIL SEALS.....	5-67
ASSEMBLING THE CRANKCASE.....	5-67
<b>CRANKSHAFT.....</b>	<b>5-69</b>
REMOVING THE CONNECTING RODS AND PISTONS.....	5-71
REMOVING THE CRANKSHAFT ASSEMBLY.....	5-71
CHECKING THE CYLINDER AND PISTON.....	5-72
CHECKING THE PISTON RINGS.....	5-72
CHECKING THE PISTON PIN.....	5-73
CHECKING THE BIG END BEARINGS.....	5-74
INSTALLING THE CONNECTING ROD AND PISTON.....	5-77
CHECKING THE CRANKSHAFT.....	5-80
CHECKING THE CRANKSHAFT DRIVE SPROCKET.....	5-80
CHECKING THE CRANKSHAFT JOURNAL BEARINGS.....	5-80
INSTALLING THE CRANKSHAFT.....	5-82
<b>TRANSMISSION.....</b>	<b>5-84</b>
REMOVING THE TRANSMISSION.....	5-89
CHECKING THE SHIFT FORKS.....	5-89
CHECKING THE SHIFT DRUM ASSEMBLY.....	5-90

---

CHECKING THE TRANSMISSION .....	5-90
INSTALLING THE TRANSMISSION.....	5-91

# ENGINE REMOVAL

EAS23710

## ENGINE REMOVAL

### Removing the drive sprocket

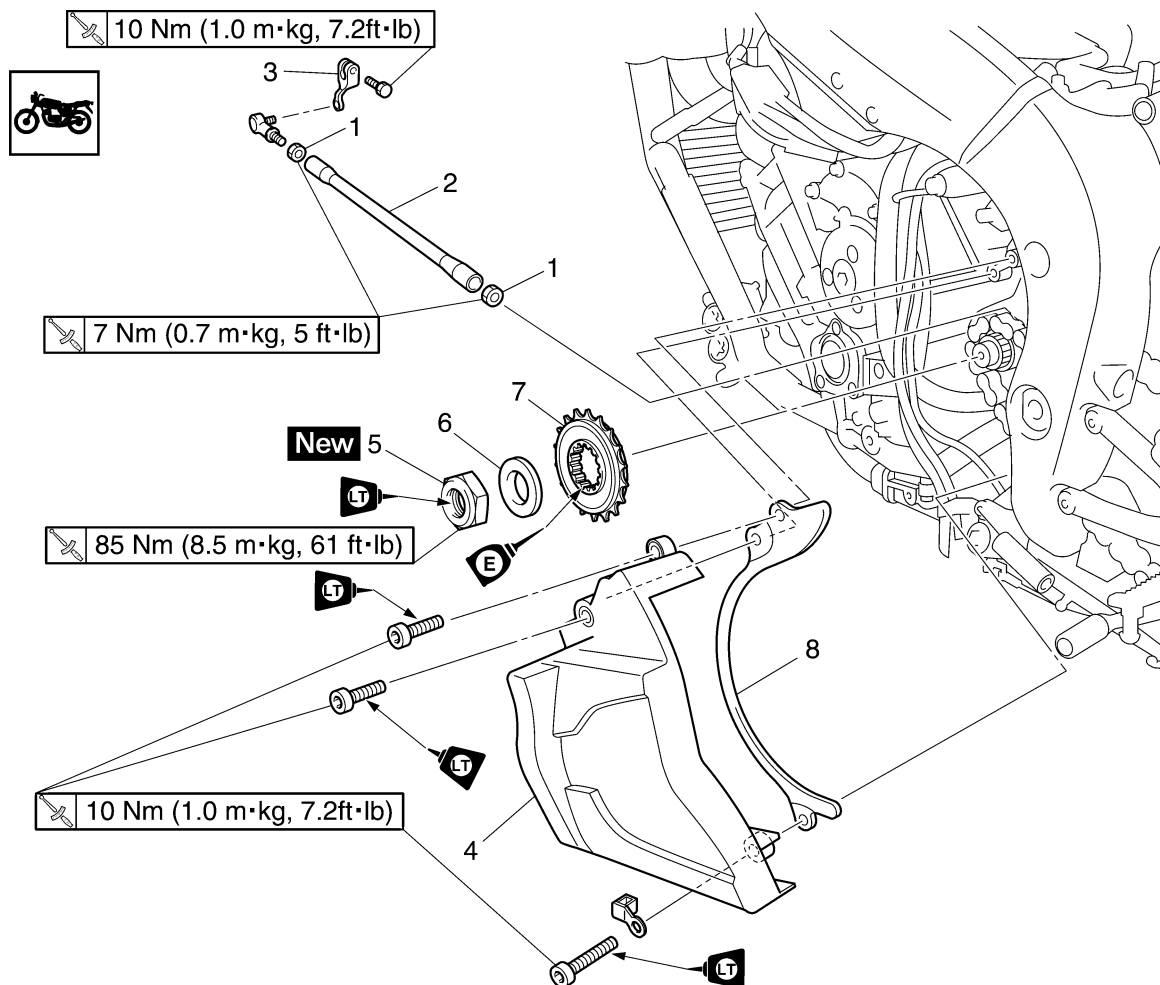

Order	Job/Parts to remove	Q'ty	Remarks
	Lower cowlings		Refer to "GENERAL CHASSIS" on page 4-1.
	Drive chain		Loosen. Refer to "ADJUSTING THE DRIVE CHAIN SLACK" on page 3-27.
1	Locknut	2	
2	Shift rod	1	
3	Sift arm	1	
4	Drive sprocket cover	1	
5	Drive sprocket nut	1	
6	Lock washer	1	
7	Drive sprocket	1	
8	Plate	1	
			For installation, reverse the removal procedure.

# ENGINE REMOVAL

## Removing the exhaust pipe

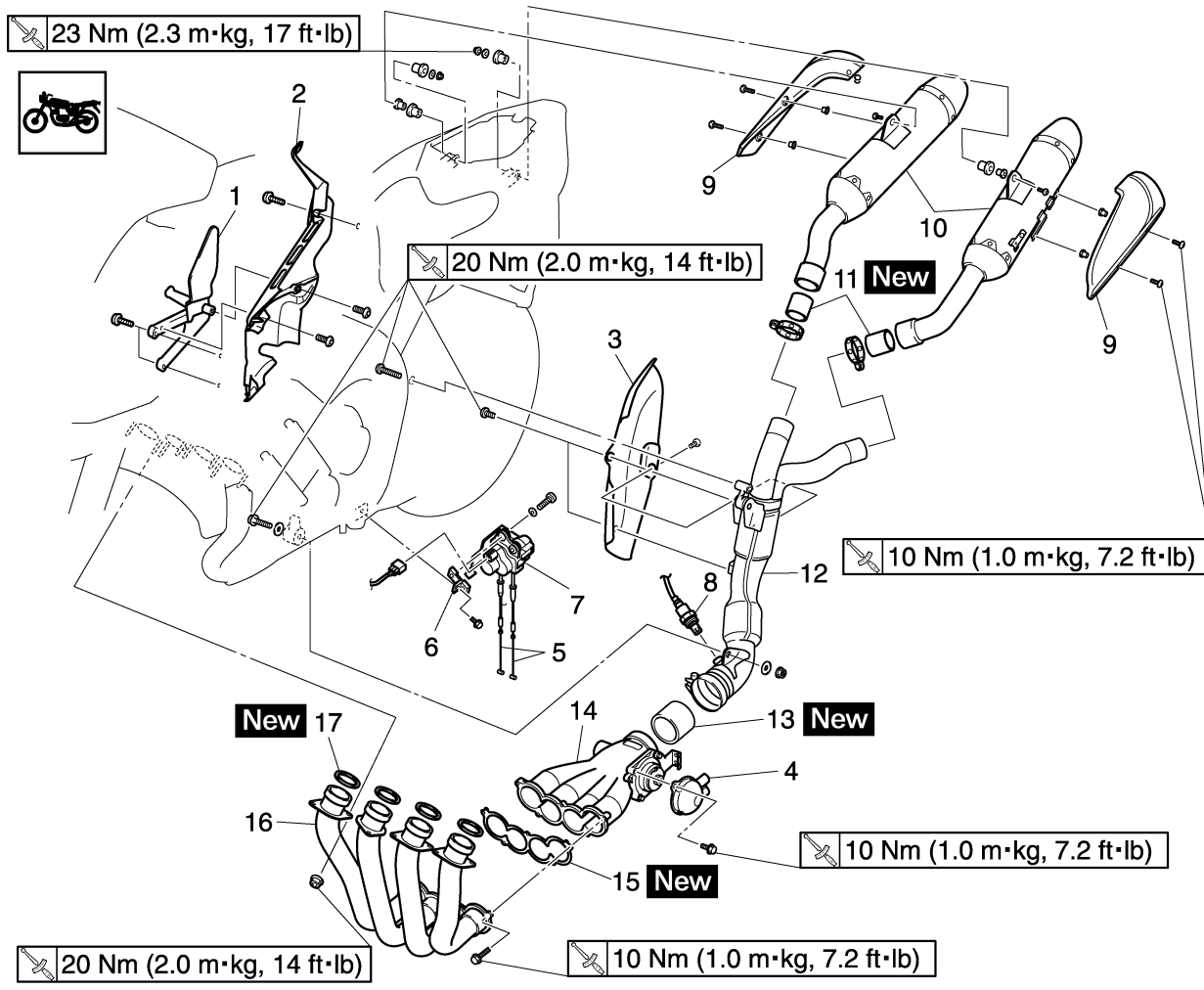

Order	Job/Parts to remove	Q'ty	Remarks
	Rider seat		Refer to "GENERAL CHASSIS" on page 4-1.
	Passenger seat		Refer to "GENERAL CHASSIS" on page 4-1.
	Side cowlings		Refer to "GENERAL CHASSIS" on page 4-1.
	Lower cowlings		Refer to "GENERAL CHASSIS" on page 4-1.
1	Right footrest bracket	1	
2	Protector cover	1	
3	Protector	1	
4	EXUP valve pulley cover	1	
5	EXUP cable	2	
6	EXUP servo motor bracket	1	
7	EXUP servo motor	1	
8	O <sub>2</sub> sensor	1	
9	Muffler cover	2	
10	Muffler	2	
11	Gasket	2	
12	Catalyst pipe assembly	1	
13	Gasket	1	
14	Exhaust valve pipe assembly	1	
15	Exhaust valve pipe gasket	1	
16	Exhaust pipe assembly	1	
17	Exhaust pipe gasket	4	

# ENGINE REMOVAL

## Removing the exhaust pipe

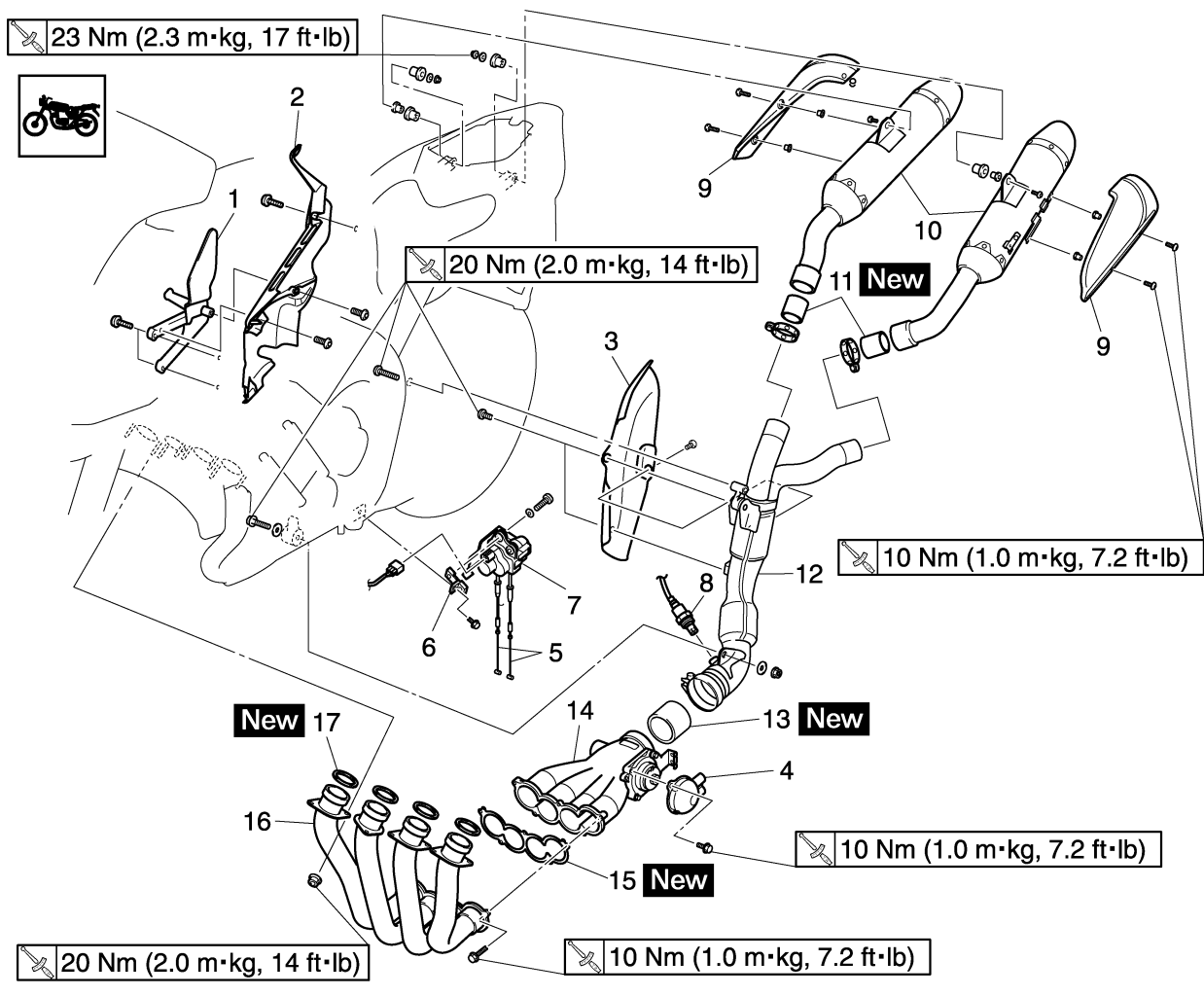

Order	Job/Parts to remove	Q'ty	Remarks
			For installation, reverse the removal procedure.

## ENGINE REMOVAL

### Disassembling the exhaust valve pipe

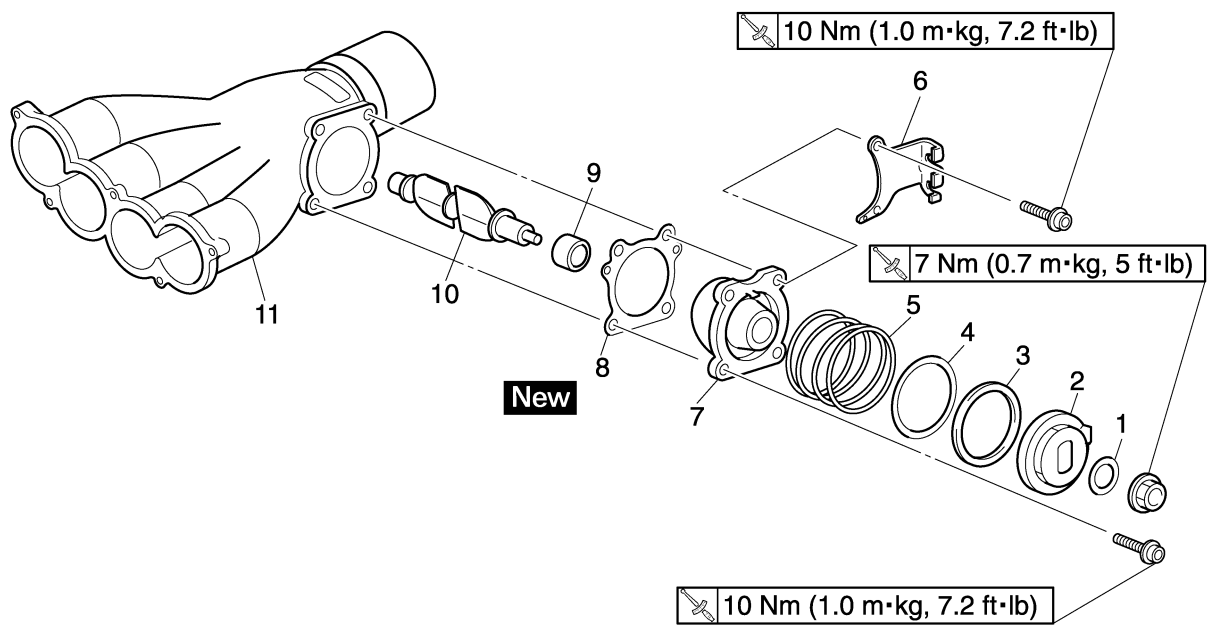

Order	Job/Parts to remove	Q'ty	Remarks
1	Washer	1	
2	Pulley	1	
3	Collar	1	
4	Plate	1	
5	Spring	1	
6	EXUP pulley bracket	1	
7	Housing	1	
8	Gasket	1	
9	Collar	1	
10	Shaft arm	1	
11	Exhaust valve pipe	1	
			For assembly, reverse the disassembly procedure.

## ENGINE REMOVAL

### Disconnecting the leads and hoses

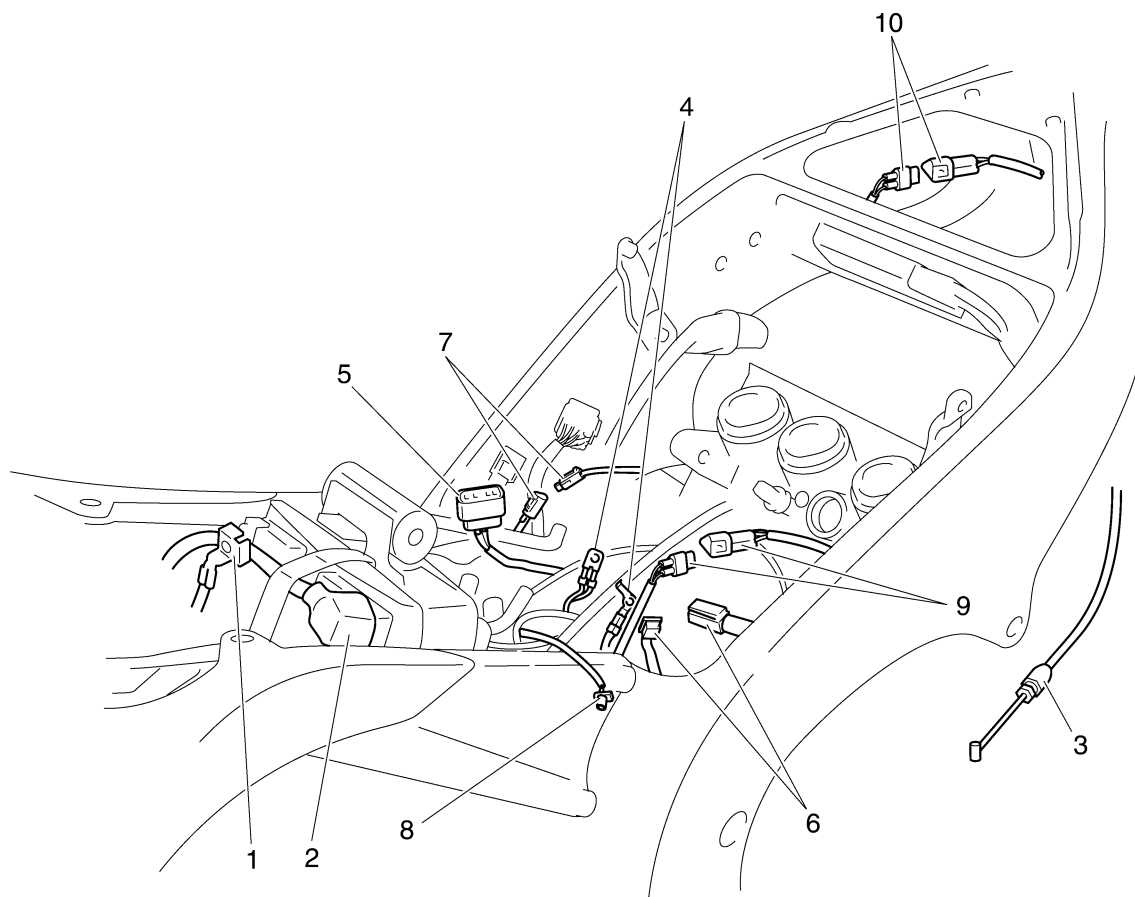

Order	Job/Parts to remove	Q'ty	Remarks
	Fuel tank		Refer to "FUEL TANK" on page 7-1.
	Air filter case		Refer to "GENERAL CHASSIS" on page 4-1.
	Throttle body		Refer to "THROTTLE BODIES" on page 7-4.
	Engine oil		Drain. Refer to "CHANGING THE ENGINE OIL" on page 3-12.
	Oil cooler		Refer to "OIL COOLER" on page 6-4.
	Air cut-off valve		Refer to "AIR INDUCTION SYSTEM" on page 7-9.
	Starter motor		Refer to "ELECTRIC STARTER" on page 5-39.
1	Battery negative lead	1	
2	Battery positive lead	1	
3	Clutch cable	1	
4	Engine ground lead	2	
5	Stator coil assembly coupler	1	Disconnect.
6	Crankshaft position sensor coupler	1	Disconnect.
7	Oil level switch connector	1	Disconnect.
8	Neutral switch connector	1	Disconnect.
9	Speed sensor coupler	1	Disconnect.
10	Cylinder identification sensor coupler	1	Disconnect.
			For installation, reverse the removal procedure.

## ENGINE REMOVAL

### Removing the engine

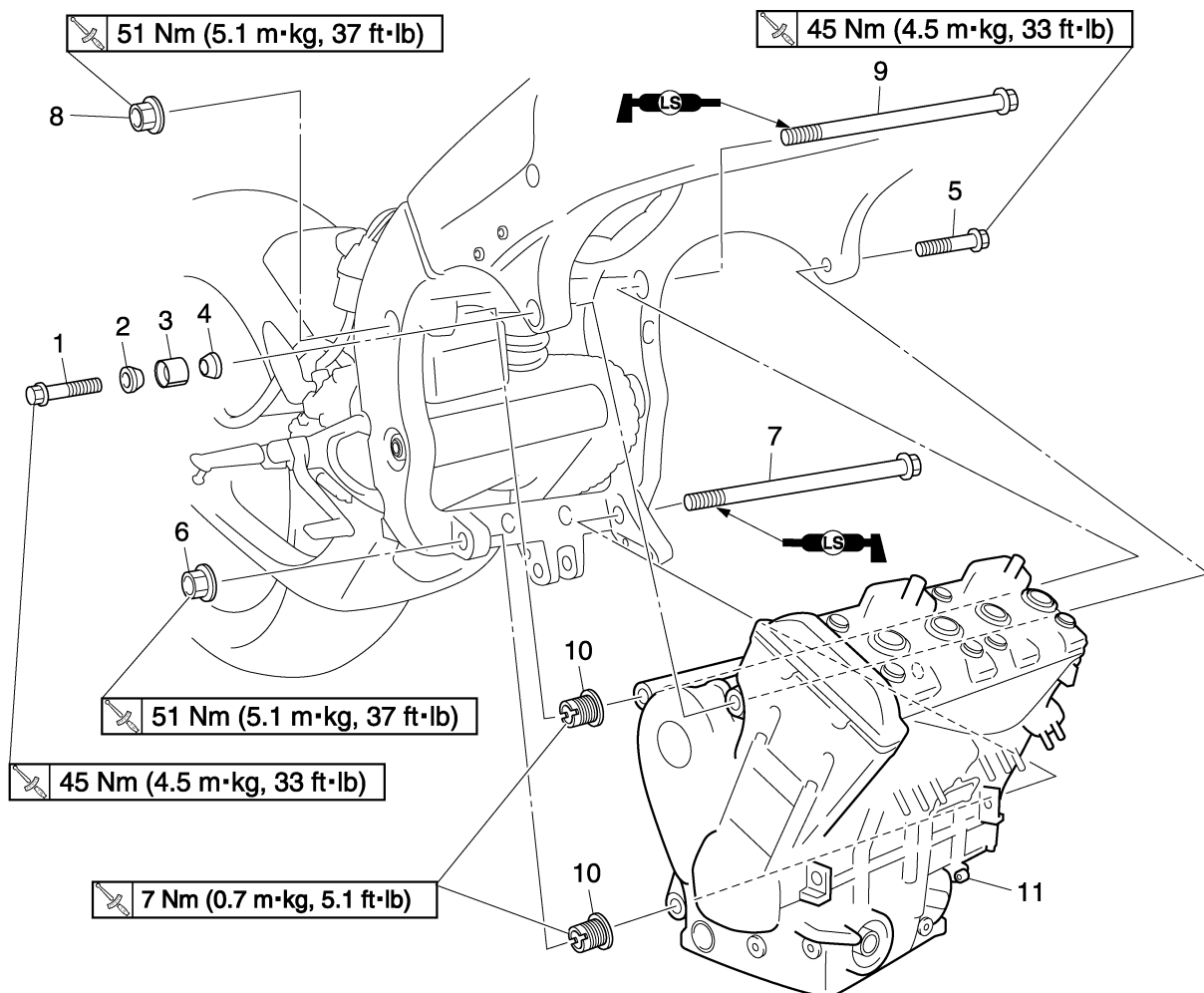

Order	Job/Parts to remove	Q'ty	Remarks
1	Engine mounting bolt (front right side)	1	
2	Engine mount collar (outer)	1	
3	Engine mount collar (center)	1	
4	Engine mount collar (inner)	1	
5	Engine mounting bolt (front left side)	1	
6	Locknut	1	
7	Engine mounting bolt (rear lower side)	1	
8	Locknut	1	
9	Engine mounting bolt (rear upper side)	1	
10	Engine mounting adjust bolt	2	
11	Engine	1	
			For installation, reverse the removal procedure.

## ENGINE REMOVAL

EAS23720

### INSTALLING THE ENGINE

1. Install:
  - Engine mounting adjust bolts (temporary tighten)
2. Install:
  - Engine
3. Install:
  - Engine mounting bolt (rear lower side) "1"
  - Engine mounting bolt (rear upper side) "2"
  - Locknuts

**NOTE:**

Lubricate the lower and upper engine mounting bolts threads with lithium-soap-based grease.

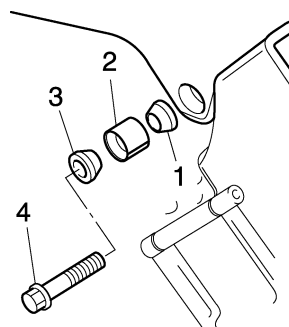

6. Tighten:
  - Engine mounting adjust bolts

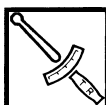

**Engine mounting adjust bolt**  
7 Nm (0.7 m·kg, 5.1 ft·lb)

**NOTE:**

Use the pivot shaft wrench "1" and pivot shaft wrench adapter "2" to tighten the engine mounting adjust bolts.

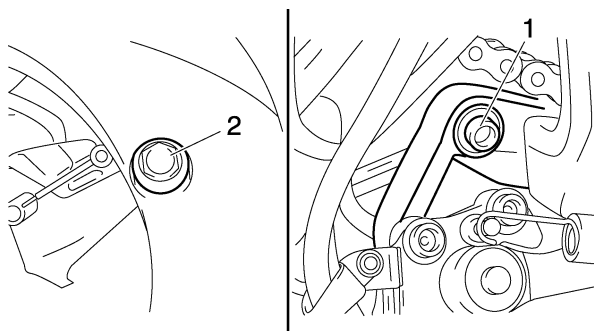

4. Install:
  - Engine mount bolt (front left side) "1" (temporary tighten)

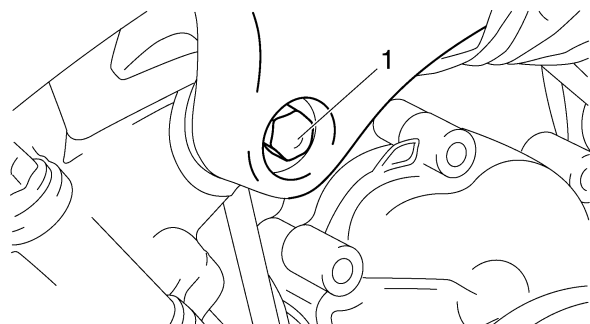

**Pivot shaft wrench**  
90890-01471  
YM-01471  
**Pivot shaft wrench adapter**  
90890-01476

5. Install:
  - Engine mount collar (inner) "1"
  - Engine mount collar (center) "2"
  - Engine mount collar (outer) "3"
  - Right front engine mount bolt "4" (temporary tighten)

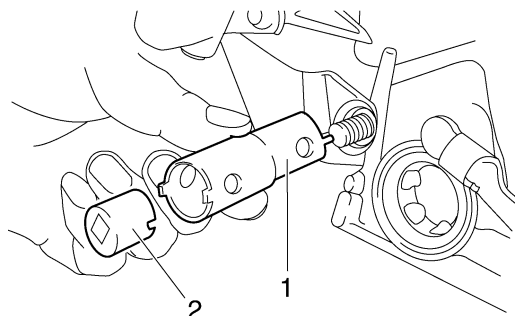

7. Tighten:
  - Upper locknut "1"
  - Lower locknut "2"

## ENGINE REMOVAL



**Upper locknut**  
51 Nm (5.1 m·kg, 37 ft·lb)  
**Lower locknut**  
51 Nm (5.1 m·kg, 37 ft·lb)



**Engine mounting bolt (front right side)**  
45 Nm (4.5 m·kg, 33 ft·lb)

**NOTE:**

First tighten the lower locknut, and then tighten the upper locknut.

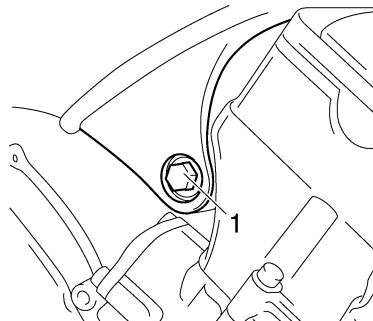
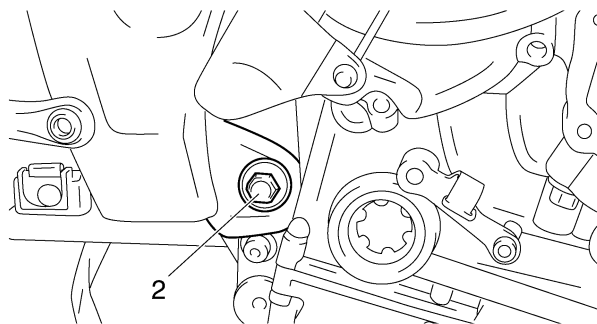
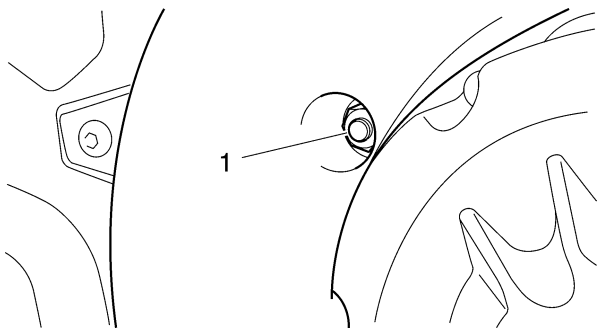

8. Tighten:

- Left front engine mounting bolt "1"



**Engine mounting bolt (front left side)**  
45 Nm (4.5 m·kg, 33 ft·lb)

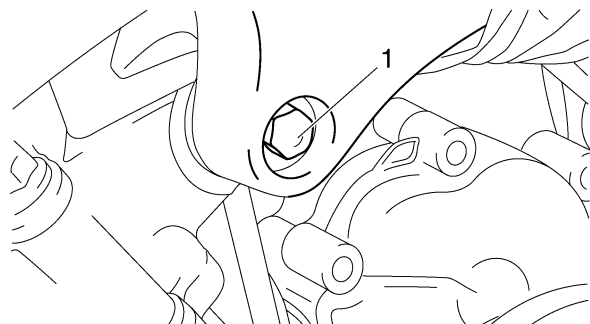

9. Tighten:

- Right front engine mounting bolt "1"

# CAMSHAFTS

EAS23760

## CAMSHAFTS

### Removing the cylinder head cover

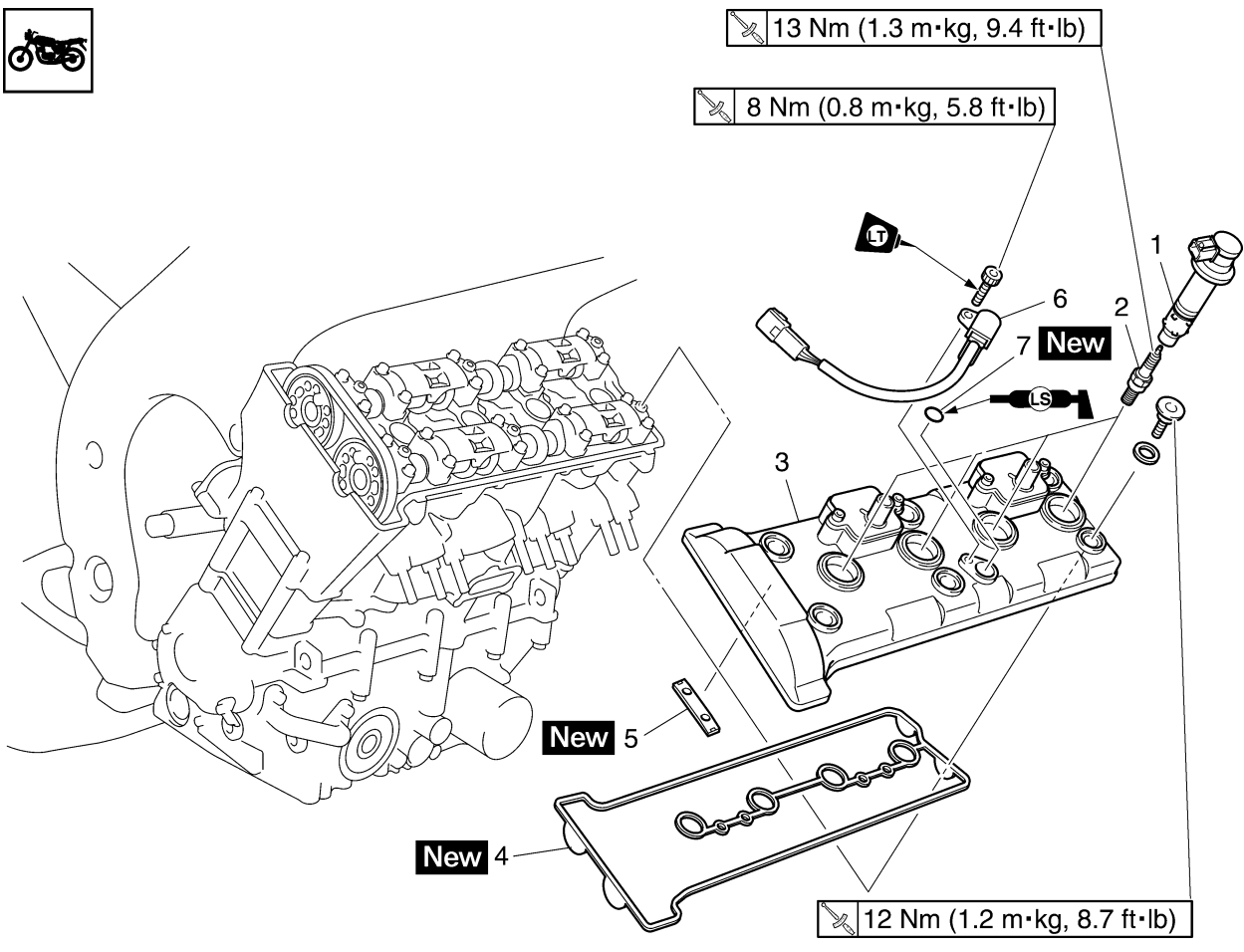

Order	Job/Parts to remove	Q'ty	Remarks
	Fuel tank		Refer to "FUEL TANK" on page 7-1.
	Side cowlings		Refer to "GENERAL CHASSIS" on page 4-1.
	Lower cowlings		Refer to "GENERAL CHASSIS" on page 4-1.
	Throttle body		Refer to "THROTTLE BODIES" on page 7-4.
	Radiator assembly		Refer to "RADIATOR" on page 6-1.
	Air cut-off valve		Refer to "AIR INDUCTION SYSTEM" on page 7-9.
1	Ignition coil	4	
2	Spark plug	4	
3	Cylinder head cover	1	
4	Cylinder head cover gasket	1	
5	Timing chain guide (top side)	1	
6	Cylinder identification sensor	1	
7	O-ring	1	
			For installation, reverse the removal procedure.

# CAMSHAFTS

## Removing the camshafts

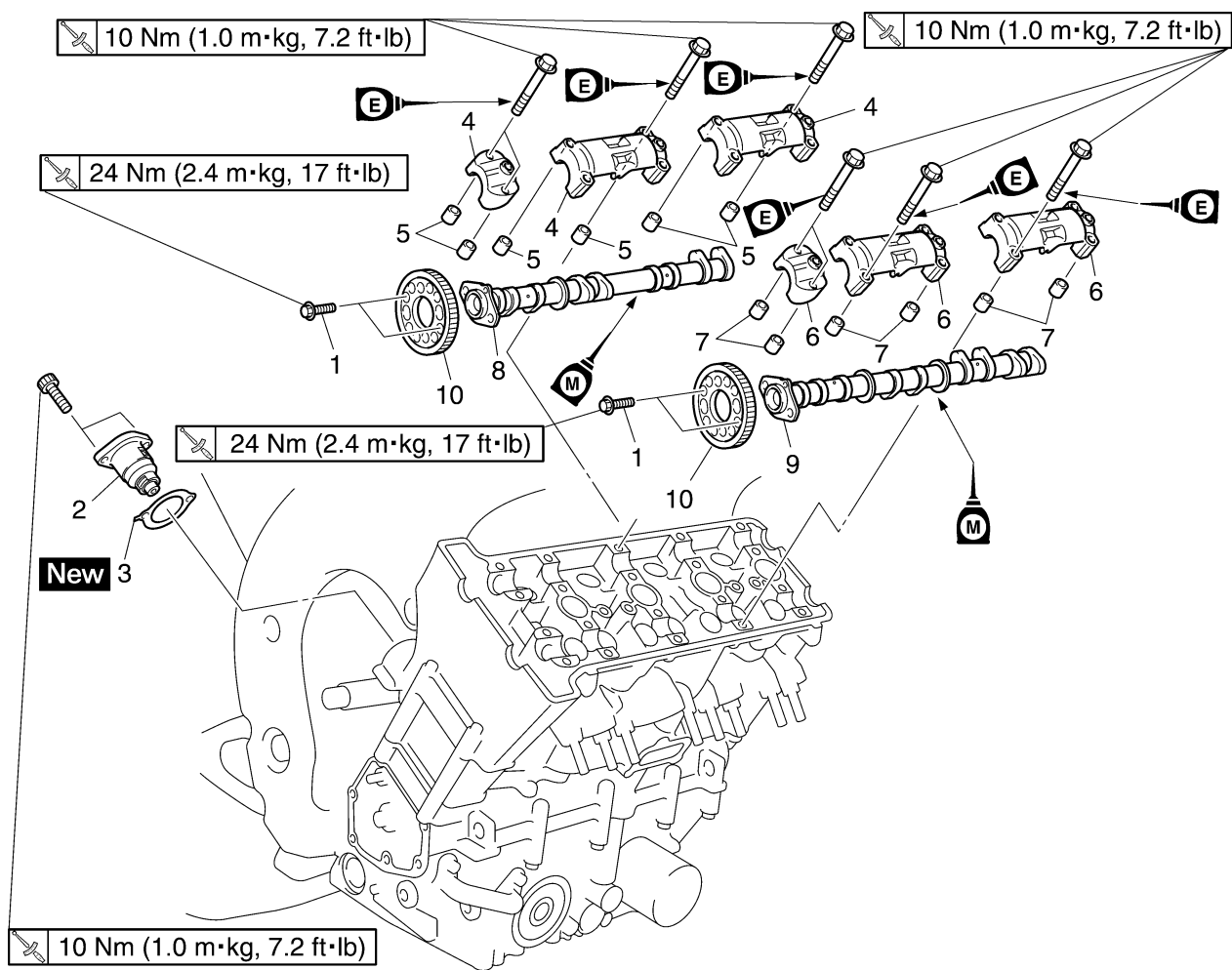

Order	Job/Parts to remove	Q'ty	Remarks
	Pickup rotor cover		Refer to "CRANKSHAFT POSITION SENSOR" on page 5-37.
1	Camshaft sprocket bolt	4	Loosen.
2	Timing chain tensioner	1	
3	Timing chain tensioner gasket	1	
4	Intake camshaft cap	3	
5	Dowel pin	6	
6	Exhaust camshaft cap	3	
7	Dowel pin	6	
8	Intake camshaft	1	
9	Exhaust camshaft	1	
10	Camshaft sprocket	2	
			For installation, reverse the removal procedure.

# CAMSHAFTS

EAS23810

## REMOVING THE CAMSHAFTS

1. Remove:
    - Pickup rotor cover  
Refer to "CRANKSHAFT POSITION SENSOR" on page 5-37.
  2. Align:
    - "T" mark "a" on the pickup rotor (with the crankcase mating surface "b")
- 
- a. Turn the crankshaft counterclockwise.
  - b. When piston #1 is at TDC on the compression stroke, align the "T" mark "a" on the pickup rotor with the crankcase mating surface "b".

**NOTE:**  
TDC on the compression stroke can be found when the camshaft lobes are turned away from each other.

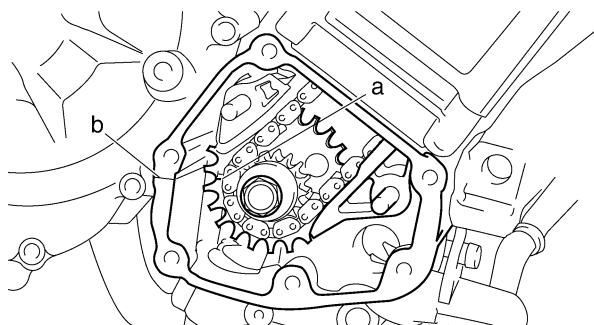

- 
3. Loosen:
    - Camshaft sprocket bolts "1"



**Camshaft wrench**

**90890-04143**

**YM-04143**

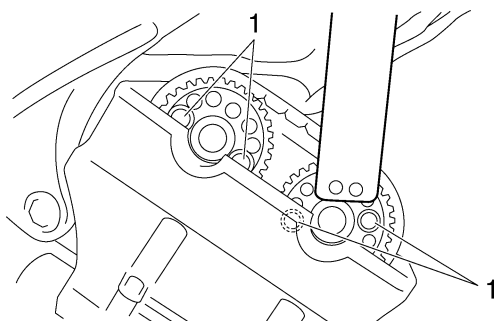

4. Remove:
  - Timing chain tensioner "1"
  - Gasket

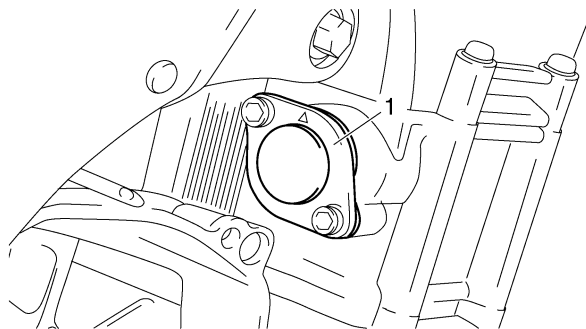

5. Remove:
  - Camshaft caps "1"
  - Dowel pins

ECA13720

**CAUTION:**

To prevent damage to the cylinder head, camshafts or camshaft caps, loosen the camshaft cap bolts in stages and in a criss-cross pattern, working from the outside in.

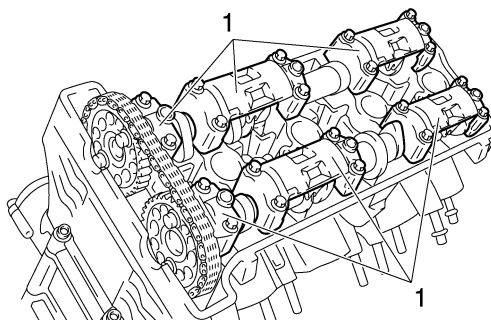

6. Remove:
  - Intake camshaft "1"
  - Exhaust camshaft "2"

**NOTE:**  
To prevent the timing chain from falling into the crankcase, fasten it with a wire "3".

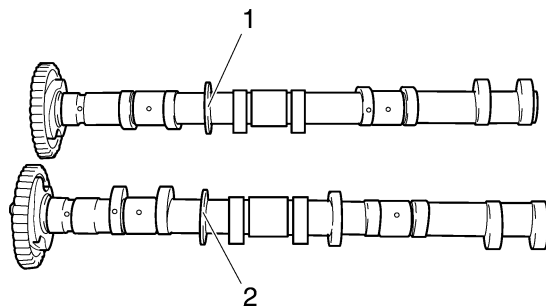

# CAMSHAFTS

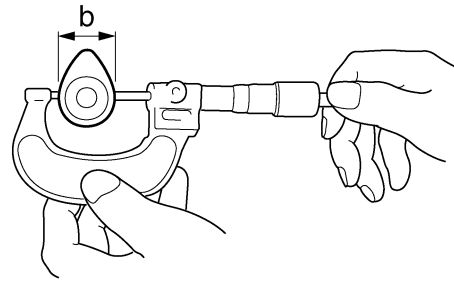
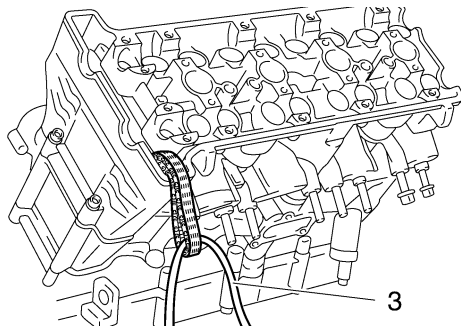

EAS23850

### CHECKING THE CAMSHAFTS

1. Check:
  - Camshaft lobes  
Blue discoloration/pitting/scratches → Replace the camshaft.
2. Measure:
  - Camshaft lobe dimensions “a” and “b”  
Out of specification → Replace the camshaft.

3. Measure:
  - Camshaft runout  
Out of specification → Replace.

	<b>Camshaft lobe dimension limit</b>
	<b>Intake A</b>
	34.450–34.550 mm (1.3563–1.3602 in)
	<b>Limit</b>
	34.350 mm (1.3524 in)
	<b>Intake B</b>
	25.170–25.270 mm (0.9909–0.9949 in)
	<b>Limit</b>
	25.070 mm (0.9870 in)
	<b>Exhaust A</b>
	33.550–33.650 mm (1.3209–1.3248 in)
	<b>Limit</b>
33.450 mm (1.3169 in)	
<b>Exhaust B</b>	
25.192–25.292 mm (0.9918–0.9957 in)	
<b>Limit</b>	
25.092 mm (0.9879 in)	

	<b>Camshaft runout limit</b>
	0.030 mm (0.0012 in)

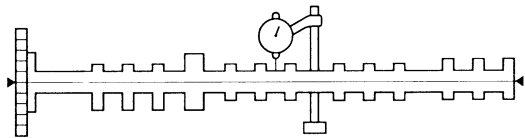

4. Measure:
  - Camshaft-journal-to-camshaft-cap clearance  
Out of specification → Measure the camshaft journal diameter.

	<b>Camshaft-journal-to-camshaft-cap clearance</b>
	0.028–0.062 mm (0.0011–0.0024 in)



- a. Install the camshaft into the cylinder head (without the dowel pins and camshaft caps).
- b. Position strip of Plastigauge® “1” onto the camshaft journal as shown.
- c. Install the dowel pins and camshaft caps.

**NOTE:**

- Tighten the camshaft cap bolts in stages and in a crisscross pattern, working from the inner caps out.
- Do not turn the camshaft when measuring the camshaft journal-to-camshaft cap clearance with the Plastigauge®.

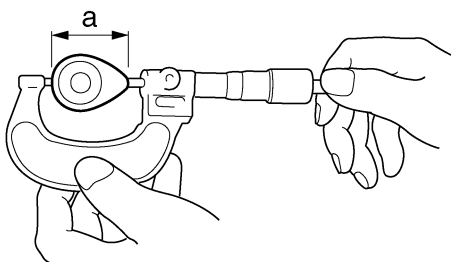

	<b>Camshaft cap bolt</b>
	10 Nm (1.0 m·kg, 7.2 ft·lb)

- d. Remove the camshaft caps and then measure the width of the Plastigauge® “2”.

# CAMSHAFTS

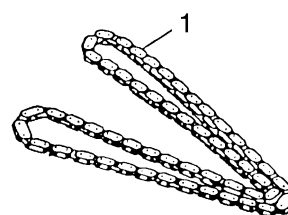
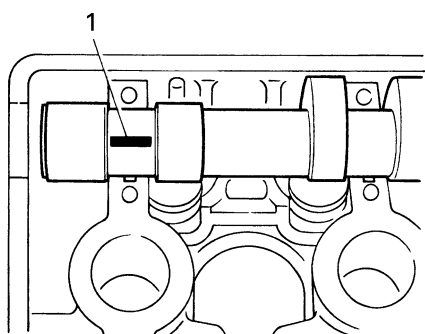

2. Check:
- Camshaft sprocket  
More than 1/4 tooth wear "a" → Replace the camshaft sprocket and the timing chain as a set.

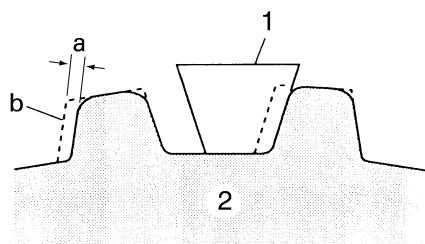
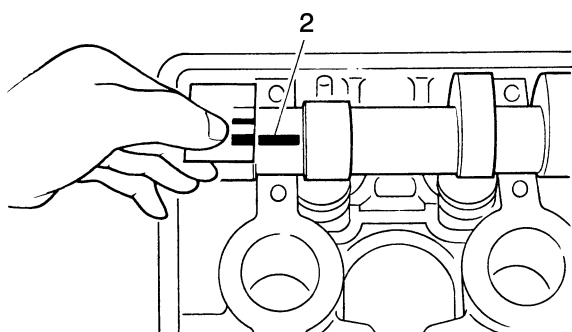

- a. 1/4 tooth
  - b. Correct
1. Timing chain roller
  2. Camshaft sprocket



5. Measure:
- Camshaft journal diameter "a"  
Out of specification → Replace the camshaft.  
Within specification → Replace the cylinder head and the camshaft caps as a set.

	<b>Camshaft journal diameter</b>
	<b>24.459–24.472 mm (0.9630–</b>
	<b>0.9635 in)</b>

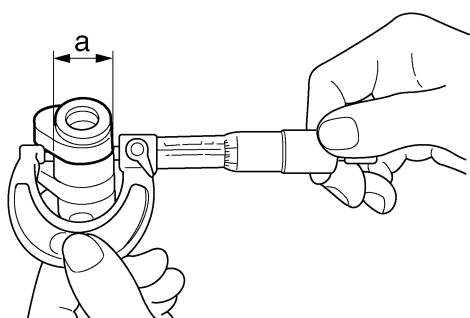

EAS23870  
**CHECKING THE TIMING CHAIN AND CAMSHAFT SPROCKET**

1. Check:
- Timing chain "1"  
Damage/stiffness → Replace the timing chain and camshaft and camshaft sprocket as a set.

EAS23950  
**CHECKING THE TIMING CHAIN GUIDES**  
The following procedure applies to all of the camshaft sprockets and timing chain guides.

1. Check:
- Timing chain guide (exhaust side) "1"
  - Timing chain guide (intake side) "2"
  - Timing chain guide (top side) "3"
- Damage/wear → Replace the defective part(s).

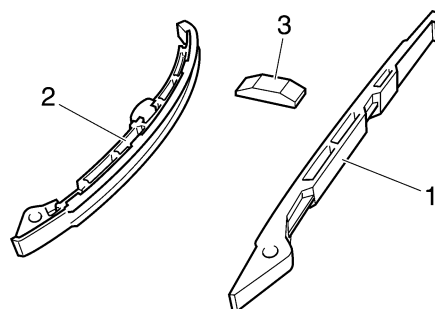

EAS23960  
**CHECKING THE TIMING CHAIN TENSIONER**

1. Remove:
- Timing chain tensioner housing "1"
  - Timing chain tensioner rod "2"
  - Timing chain tensioner spring "3"



# CAMSHAFTS

EAS24000

## INSTALLING THE CAMSHAFTS

### 1. Align:

- "T" mark "a" on the pickup rotor (with the crankcase mating surface "b")



- Turn the crankshaft clockwise.
- When position #1 is at TDC, align the "T" mark "a" with the crankcase mating surface "b".

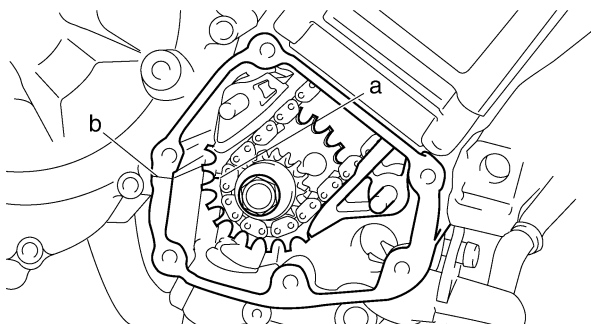

### 2. Install:

- Intake camshaft sprocket "1"
- Exhaust camshaft sprocket "2" (with the camshaft sprockets temporarily tightened)

#### NOTE:

Install the camshaft sprockets as a illustration.

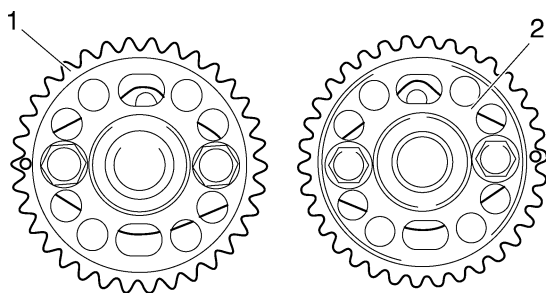

### 3. Install:

- Exhaust camshaft "1"
- Intake camshafts "2" (with the camshaft sprockets temporarily tightened)

#### NOTE:

Make sure the punch mark "a" on each camshaft faces up.

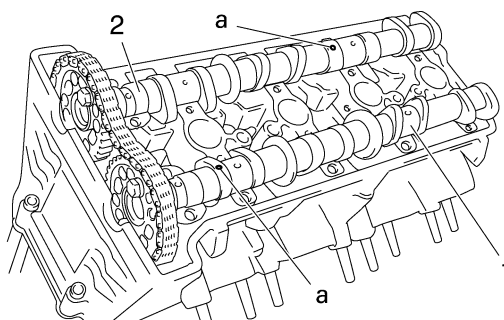

### 4. Install:

- Dowel pins
- Intake camshaft caps
- Exhaust camshaft caps

#### NOTE:

- Make sure each camshaft cap is installed in its original place. Refer to the identification marks as follows:

- "I": Intake side camshaft cap mark
- "E": Exhaust side camshaft cap mark
- "IL": Intake left side camshaft cap mark
- "IR": Intake right side camshaft cap mark
- "EL": Exhaust left side camshaft cap mark
- "ER": Exhaust right side camshaft cap mark

- Make sure the arrow mark "a" on each camshaft points towards the right side of the engine.

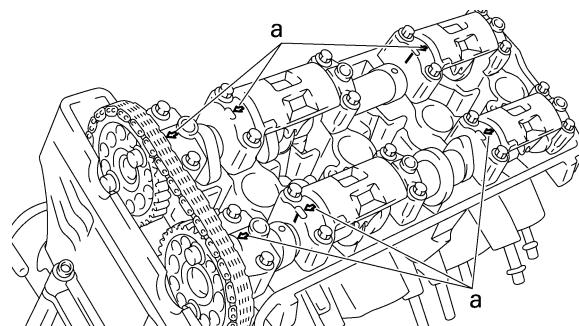

### 5. Install:

- Camshaft cap bolts

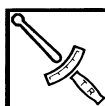

**Camshaft cap bolt**  
10 Nm (1.0 m·kg, 7.2 ft·lb)

#### NOTE:

Tighten the camshaft cap bolts in stages and in a crisscross pattern, working from the inner caps out.

## CAMSHAFTS

ECA4C81004

**CAUTION:**

- Lubricate the camshaft cap bolts with the engine oil.
- The camshaft cap bolts must be tightened evenly or damage to the cylinder head, camshaft caps, and camshafts will result.
- Do not turn the crankshaft when installing the camshaft to avoid damage or improper valve timing.

6. Tighten:

- Camshaft sprocket bolts "1"

	<b>Camshaft sprocket bolt</b> 24 Nm (2.4 m·kg, 17 ft·lb)
---	---

	<b>Camshaft wrench</b> 90890-04143
---	---------------------------------------

ECA4C81005

**CAUTION:**

Be sure to tighten the camshaft sprocket bolts to the specified torque to avoid the possibility of the bolts coming loose and damaging the engine.

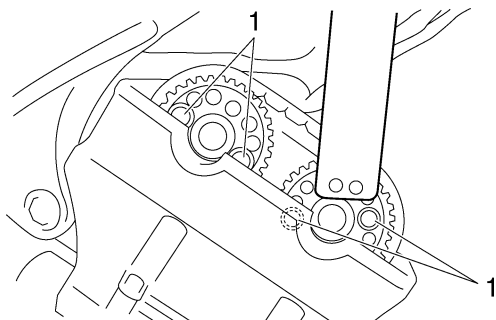

7. Align:

- Camshaft punch mark "a"  
Align the camshaft punch mark "a" and the camshaft cap arrow mark "b".

	<b>Camshaft wrench</b> 90890-04143
---	---------------------------------------

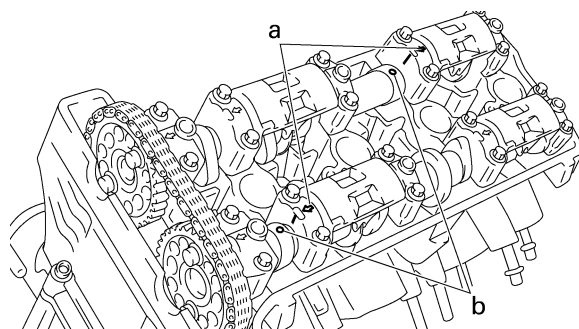

8. Install:

- Gasket **New**
- Timing chain tensioner "1"
- Timing chain tensioner bolts "2"

	<b>Timing chain tensioner bolt</b> 10 Nm (1.0 m·kg, 7.2 ft·lb)
---	---

ECA4C81006

**CAUTION:**

The arrow mark "a" on the timing chain tensioner should face up.

EWA4C81004

**! WARNING**

Always use a new gasket.

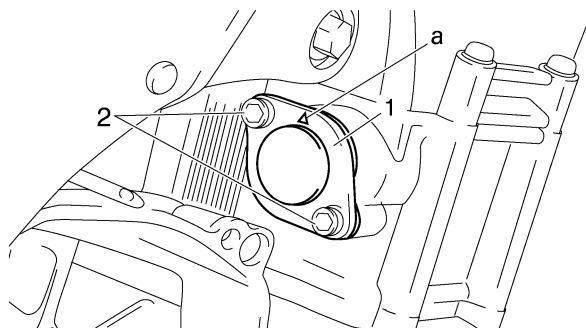

9. Turn:

- Crankshaft  
(several turns clockwise)

10. Check:

- "T" mark "a"  
Make sure the "T" mark on the pickup rotor is aligned with the crankcase mating surface "b".
- Camshaft punch mark "c"  
Make sure the punch mark "c" on the camshaft is aligned with the camshaft cap arrow mark "d".  
Out of alignment → Adjust.  
Refer to the installation steps above.

## CAMSHAFTS

---

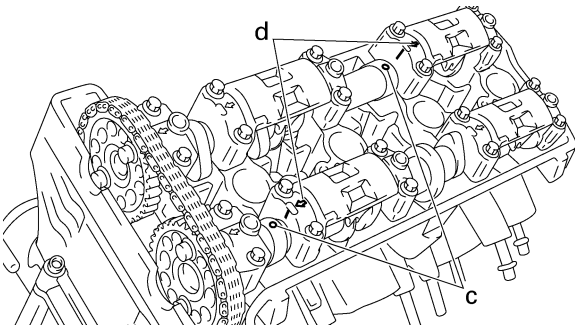
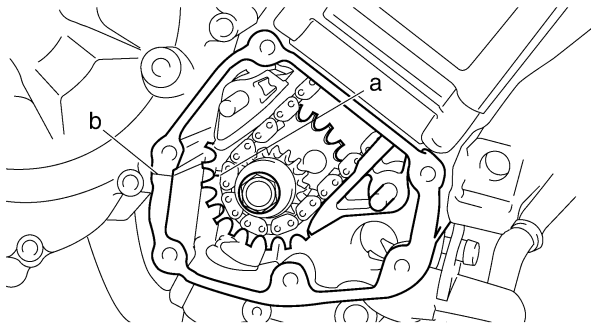

**11. Measure:**

- Valve clearance  
Out of specification → Adjust.  
Refer to "ADJUSTING THE VALVE CLEARANCE" on page 3-4.

**12. Install:**

- Pickup coil rotor cover  
"CRANKSHAFT POSITION SENSOR" on page 5-37.

# CYLINDER HEAD

EAS24100

## CYLINDER HEAD

### Removing the cylinder head

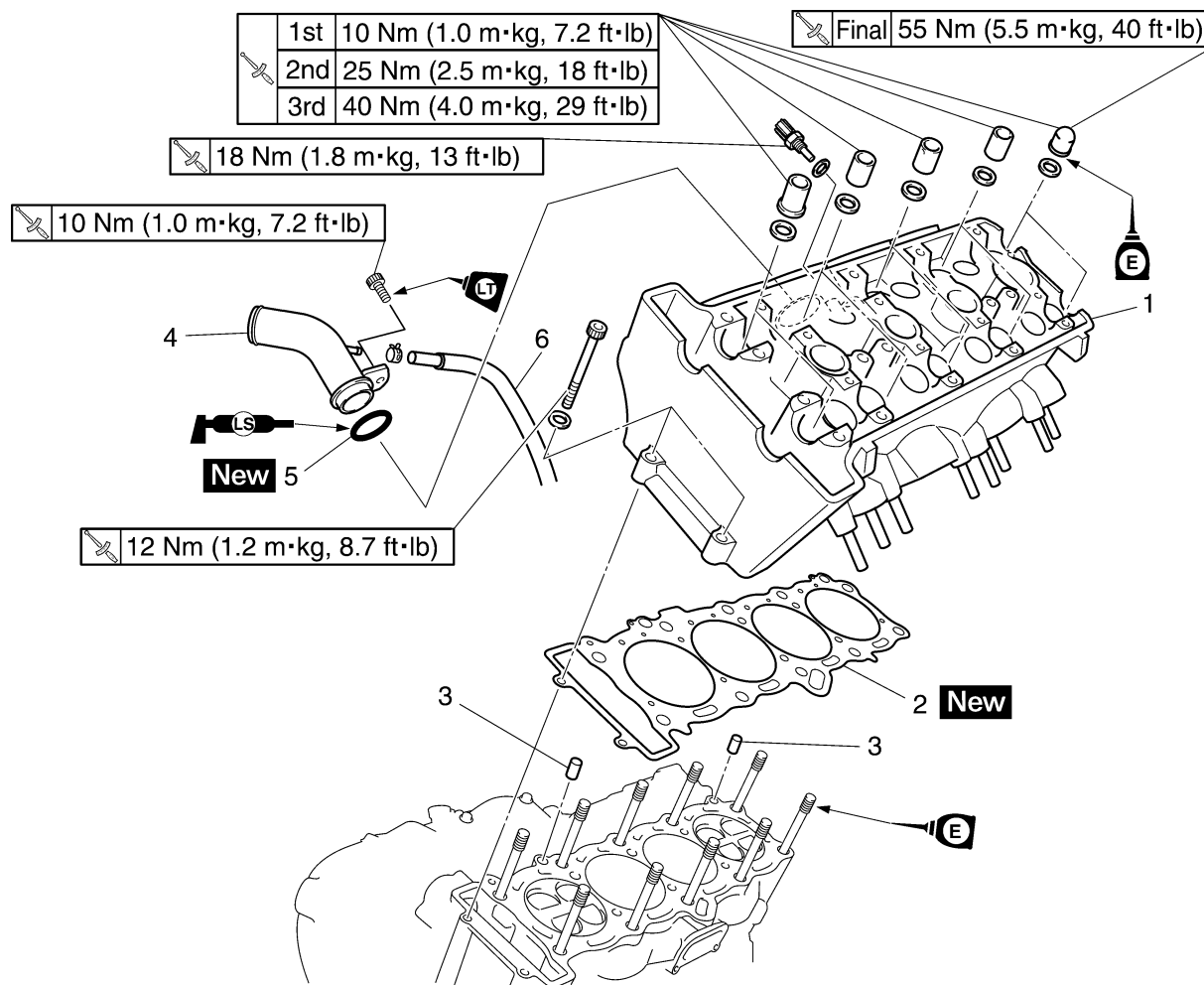

Order	Job/Parts to remove	Q'ty	Remarks
	Engine		Refer to "ENGINE REMOVAL" on page 5-1.
	Intake camshaft		Refer to "CAMSHAFTS" on page 5-9.
	Exhaust camshaft		Refer to "CAMSHAFTS" on page 5-9.
1	Cylinder head	1	
2	Cylinder head gasket	1	
3	Dowel pin	2	
4	Coolant pipe	1	
5	O-ring	1	
6	Water pump breather hose	1	
			For installation, reverse the removal procedure.

## CYLINDER HEAD

EAS24120

### REMOVING THE CYLINDER HEAD

1. Remove:
  - Intake camshaft
  - Exhaust camshaft
 Refer to "REMOVING THE CAMSHAFTS" on page 5-11.
2. Remove:
  - Cylinder head nuts
  - Cylinder head bolts

**NOTE:**

- Loosen the nuts in the proper sequence as shown.
- Loosen each nut 1/2 of a turn at a time. After all of the nuts are fully loosened, remove them.

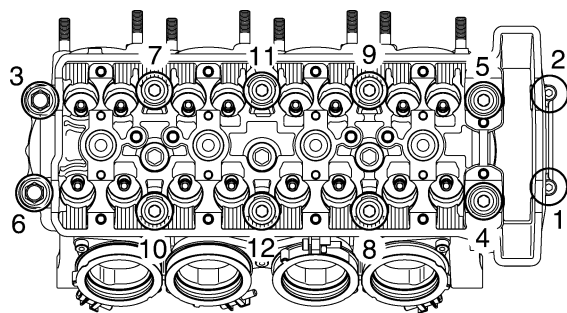

EAS24160

### CHECKING THE CYLINDER HEAD

1. Eliminate:
  - Combustion chamber carbon deposits (with a rounded scraper)

**NOTE:**

Do not use a sharp instrument to avoid damaging or scratching:

- Spark plug bore threads
- Valve seats

2. Check:
  - Cylinder head  
Damage/scratches → Replace.

**NOTE:**

Replace the titanium valves with the cylinder head.

Refer to "CHECKING THE VALVE SEATS" on page 5-25.

- Cylinder head water jacket  
Mineral deposits/rust → Eliminate.
3. Measure:
    - Cylinder head warpage  
Out of specification → Resurface the cylinder head.



**Warpage limit**  
**0.10 mm (0.0039 in)**

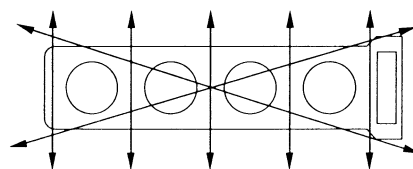

- a. Place a straightedge "1" and a thickness gauge "2" across the cylinder head.

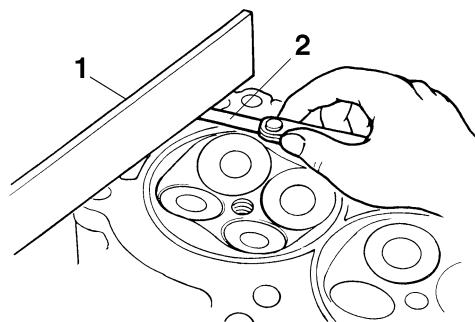

- b. Measure the warpage.
- c. If the limit is exceeded, resurface the cylinder head as follows.
- d. Place a 400–600 grit wet sandpaper on the surface plate and resurface the cylinder head using a figure-eight sanding pattern.

**NOTE:**

To ensure an even surface, rotate the cylinder head several times.



EAS24240

### INSTALLING THE CYLINDER HEAD

1. Check:
  - Cylinder head bolts "1"

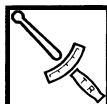

**Cylinder head bolt**  
**8 Nm (0.8 m.kg, 5.8 ft.lb)**

**NOTE:**

Retighten the cylinder head bolts to specification, before installing the cylinder head.

## CYLINDER HEAD

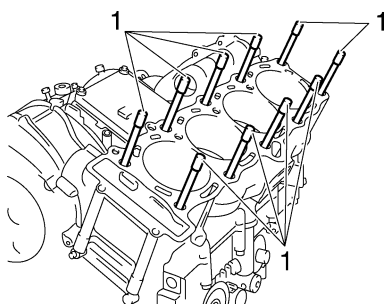

2. Install:

- Gasket "1" **New**
- Dowel pins

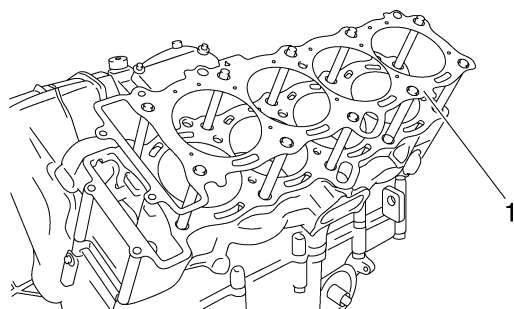

3. Install:

- Cylinder head

**NOTE:**

Pass the timing chain through the timing chain cavity.

4. Tighten:

- Cylinder head nuts "1" – "10"

	<b>Cylinder head nut (1st)</b> 10 Nm (1.0 m·kg, 7.2 ft·lb)
---	---

	<b>Cylinder head nut (2nd)</b> 25 Nm (2.5 m·kg, 18 ft·lb)
---	--

	<b>Cylinder head nut (3rd)</b> 40 Nm (4.0 m·kg, 29 ft·lb)
---	--

- Cylinder head nuts "7" "10"

	<b>Cylinder head nut (final)</b> 55 Nm (5.5 m·kg, 40 ft·lb)
---	--

- Cylinder head bolts "11" "12"

	<b>Cylinder head bolt</b> 12 Nm (1.2 m·kg, 8.7 ft·lb)
---	--

**NOTE:**

- First, tighten the nuts "1" – "10" to approximately 10 Nm (1.0 m·kg, 7.2 ft·lb) with a torque wrench, and then tighten the 25 Nm (2.5 m·kg, 18 ft·lb).
- Retighten the nuts "1" – "10" to 40 Nm (4.0 m·kg, 29 ft·lb) with a torque wrench.
- Final, tighten the nuts "7", "10" to 55 Nm (5.5 m·kg, 40 ft·lb) with a torque wrench.
- Lubricate the cylinder head nuts with engine oil.
- Tighten the cylinder head nuts in the proper tightening sequence as shown and torque them in four stages.

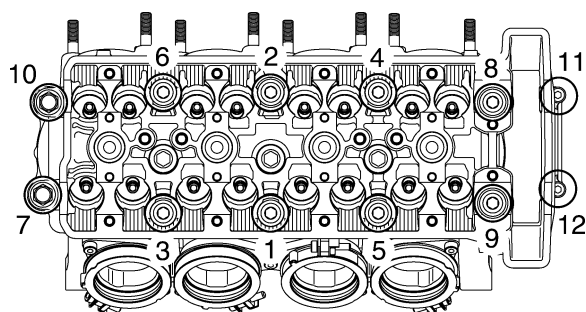

5. Install:

- Exhaust camshaft
  - Intake camshaft
- Refer to "INSTALLING THE CAMSHAFTS" on page 5-15.

# VALVES AND VALVE SPRINGS

EAS24270

## VALVES AND VALVE SPRINGS

### Removing the valves and valve springs

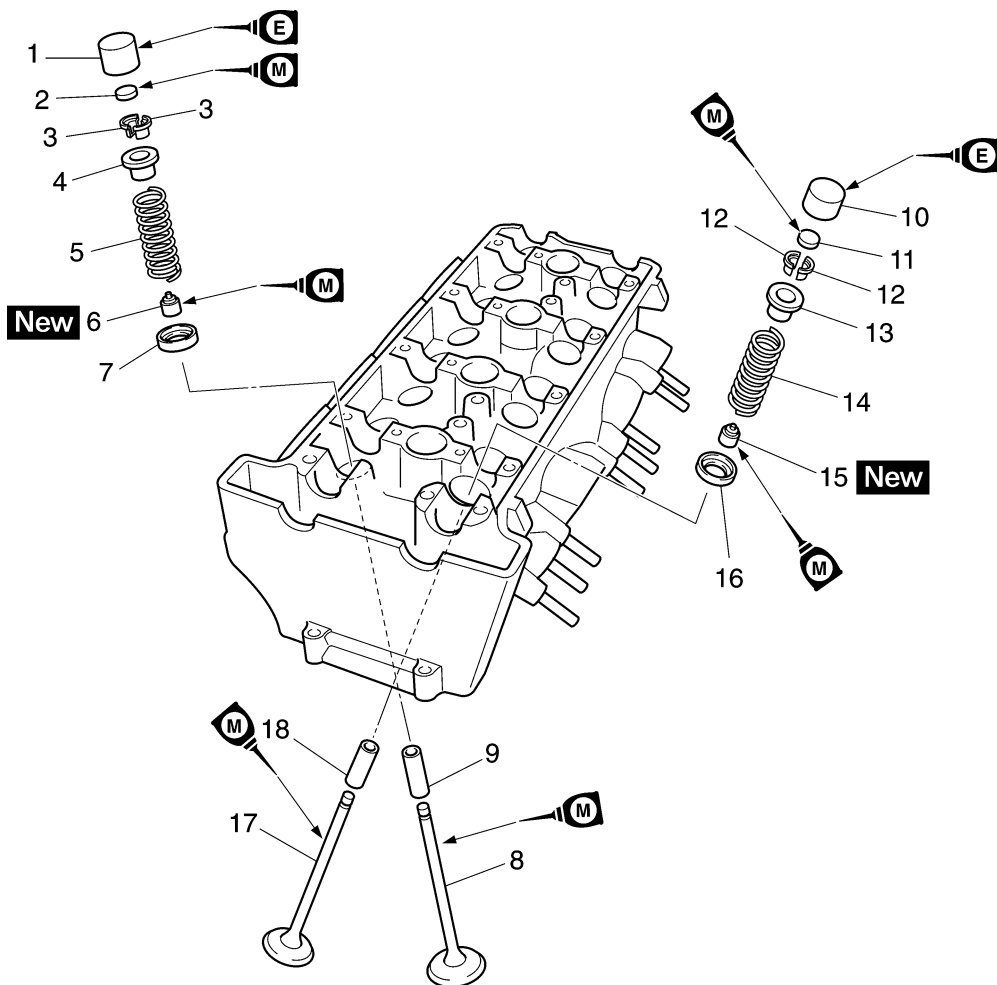

Order	Job/Parts to remove	Q'ty	Remarks
	Cylinder head		Refer to "CYLINDER HEAD" on page 5-18.
1	Intake valve lifter	8	
2	Intake valve pad	8	
3	Intake valve cotter	16	
4	Intake valve upper spring seat	8	
5	Intake valve spring	8	
6	Intake valve oil seal	8	
7	Intake valve lower spring seat	8	
8	Intake valve	8	
9	Intake valve guide	8	
10	Exhaust valve lifter	8	
11	Exhaust valve pad	8	
12	Exhaust valve cotter	16	
13	Exhaust valve upper spring seat	8	
14	Exhaust valve spring	8	
15	Exhaust valve oil seal	8	
16	Exhaust valve lower spring seat	8	
17	Exhaust valve	8	
18	Exhaust valve guide	8	

## VALVES AND VALVE SPRINGS

### Removing the valves and valve springs

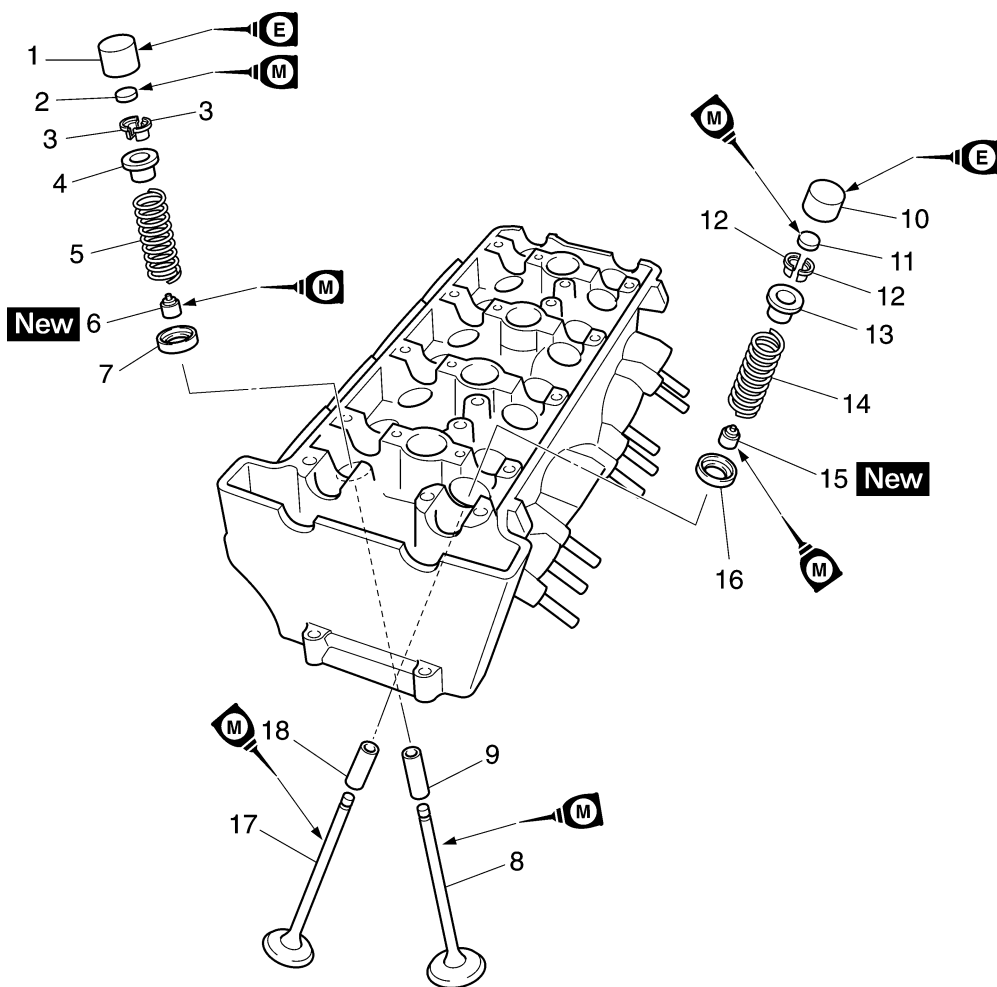

Order	Job/Parts to remove	Q'ty	Remarks
			For installation, reverse the removal procedure.



## VALVES AND VALVE SPRINGS

1. Measure:
  - Valve-stem-to-valve-guide clearance  
Out of specification → Replace the valve guide.

- Valve-stem-to-valve-guide clearance =  
Valve guide inside diameter "a" -  
Valve stem diameter "b"



**Valve-stem-to-valve-guide clearance**

**Valve-stem-to-valve-guide clearance (intake)**  
0.010–0.037 mm (0.0004–0.0015 in)  
**Limit**  
0.080 mm (0.0032 in)

**Valve-stem-to-valve-guide clearance (exhaust)**  
0.025–0.052 mm (0.0010–0.0020 in)  
**Limit**  
0.100 mm (0.0039 in)

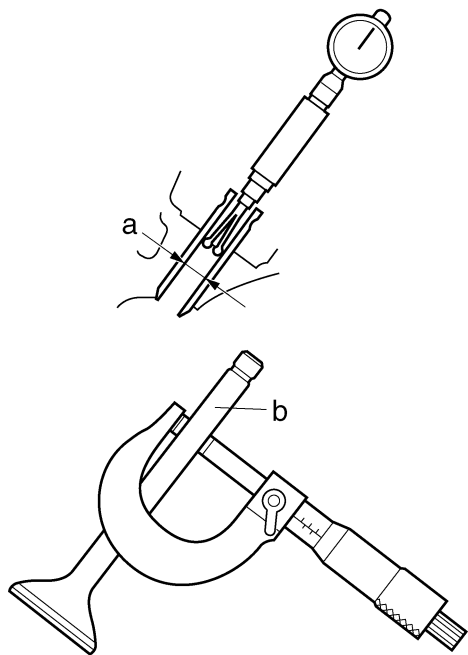

2. Replace:
  - Valve guide

**NOTE:** \_\_\_\_\_  
To ease valve guide removal and installation, and to maintain the correct fit, heat the cylinder head to 100°C (212°F) in an oven.

- a. Remove the valve guide with the valve guide remover "1".

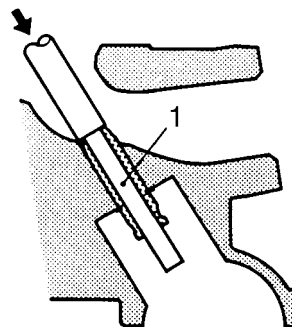

- b. Install the new valve guide with the valve guide installer "2" and valve guide remover "1".

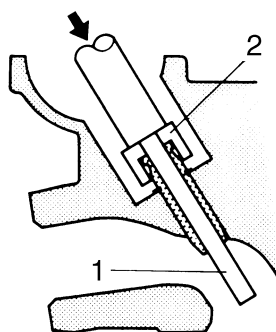

- c. After installing the valve guide, bore the valve guide with the valve guide reamer "3" to obtain the proper valve-stem-to-valve-guide clearance.

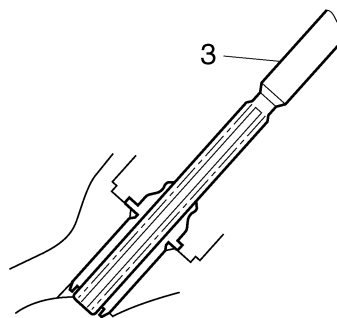

**NOTE:** \_\_\_\_\_  
After replacing the valve guide, reface the valve seat.



## VALVES AND VALVE SPRINGS



- Valve guide remover (ø4.5)**  
90890-04116
- Valve guide remover (4.5 mm)**  
YM-04116
- Valve guide remover (ø5)**  
90890-04097
- Valve guide remover (5.0 mm)**  
YM-04097
- Valve guide installer (ø4.5)**  
90890-04117
- Valve guide installer (4.5 mm)**  
YM-04117
- Valve guide installer (ø5)**  
90890-04098
- Valve guide installer (5.0 mm)**  
YM-04098
- Valve guide reamer (ø4.5)**  
90890-04118
- Valve guide reamer (4.5 mm)**  
YM-04118
- Valve guide reamer (ø5)**  
90890-04099
- Valve guide reamer (5.0 mm)**  
YM-04099

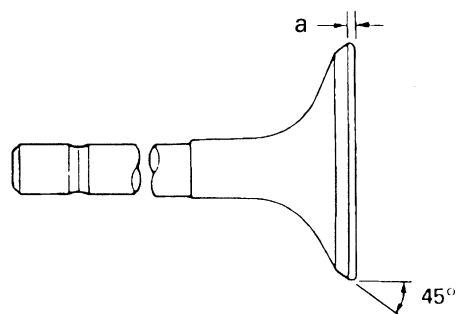

6. Measure:
  - Valve stem runout
  - Out of specification → Replace the valve.

**NOTE:**

- When installing a new valve, always replace the valve guide.
- If the valve is removed or replaced, always replace the oil seal.



**Valve stem runout**  
Valve stem runout  
0.010 mm (0.0004 in)



3. Eliminate:
  - Carbon deposits  
(from the valve face and valve seat)
4. Check:
  - Valve face  
Pitting/wear → Grind the valve face.
  - Valve stem end  
Mushroom shape or diameter larger than the body of the valve stem → Replace the valve.
5. Measure:
  - Valve margin thickness “a”  
Out of specification → Replace the valve.



**Valve margin thickness**  
Valve margin thickness D  
(intake)  
1.10–1.50 mm (0.0433–0.0591 in)  
Valve margin thickness D  
(exhaust)  
0.50–0.90 mm (0.0197–0.0354 in)

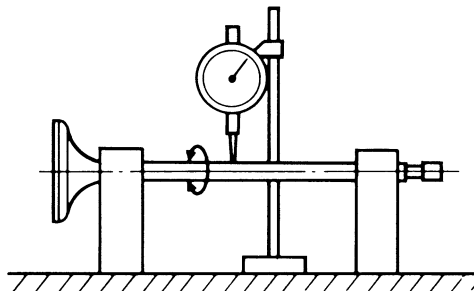

EAS24300

**CHECKING THE VALVE SEATS**

The following procedure applies to all of the valves and valve seats.

1. Eliminate:
  - Carbon deposits  
(from the valve face and valve seat)
2. Check:
  - Valve seat  
Pitting/wear → Replace the cylinder head.
3. Measure:
  - Valve seat width “a”  
Out of specification → Replace the cylinder head.

## VALVES AND VALVE SPRINGS



**Valve seat width**  
**Valve seat width C (intake)**  
 0.90–1.10 mm (0.0354–0.0433 in)  
**Valve seat width C (exhaust)**  
 0.90–1.10 mm (0.0354–0.0433 in)

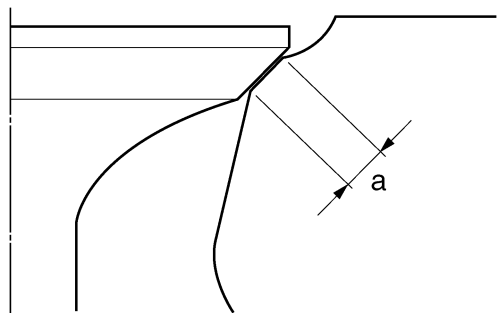

a. Apply Mechanic's blueing dye (Dykem) "b" onto the valve face.

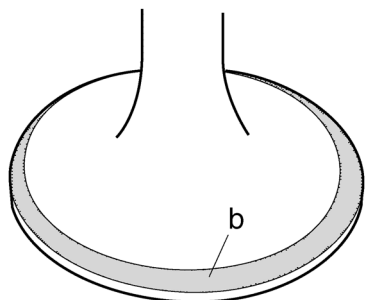

- b. Install the valve into the cylinder head.
- c. Press the valve through the valve guide and onto the valve seat to make a clear impression.
- d. Measure the valve seat width.

**NOTE:**  
 Where the valve seat and valve face contacted one another, the blueing will have been removed.

4. Lap:
- Valve face
  - Valve seat

**NOTE:**  
 After replacing the cylinder head or replacing the valve and valve guide, the valve seat and valve face should be lapped.

ECA4C81012

**CAUTION:**

**This model uses titanium intake valves. Titanium valves that have been used to lap the valve seats must not be used. Always replace lapped valves with new valves.**

**NOTE:**

- When replacing the cylinder head, replace the valves without lapping the valve seats and valve faces.
- When replacing the valves or valves guides, use new valves to lap the valve seats, and then replace them with new valves.

a. Apply a coarse lapping compound "a" to the valve face.

ECA13790

**CAUTION:**

**Do not let the lapping compound enter the gap between the valve stem and the valve guide.**

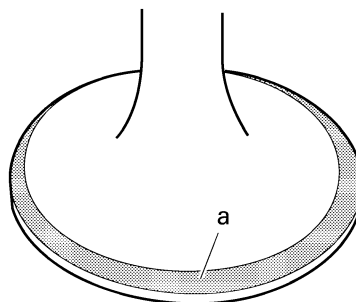

11171601

- b. Apply molybdenum disulfide oil onto the valve stem.
- c. Install the valve into the cylinder head.
- d. Turn the valve until the valve face and valve seat are evenly polished, then clean off all of the lapping compound.

**NOTE:**

For the best lapping results, lightly tap the valve seat while rotating the valve back and forth between your hands.

## VALVES AND VALVE SPRINGS

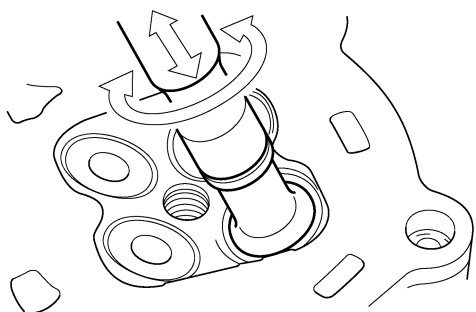

- e. Apply a fine lapping compound to the valve face and repeat the above steps.
- f. After every lapping procedure, be sure to clean off all of the lapping compound from the valve face and valve seat.
- g. Apply Mechanic's blueing dye (Dykem) "b" onto the valve face.

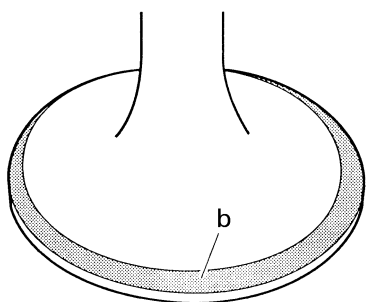

11171601

- h. Install the valve into the cylinder head.
- i. Press the valve through the valve guide and onto the valve seat to make a clear impression.
- j. Measure the valve seat width "c" again. If the valve seat width is out of specification, reface and lap the valve seat.

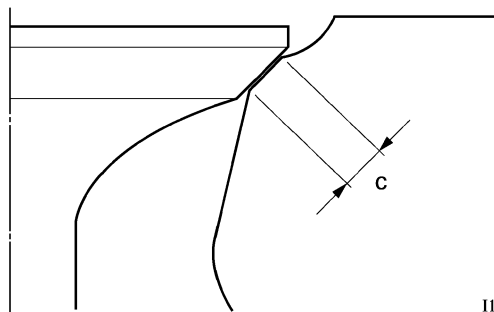

11171603

EAS24310

### CHECKING THE VALVE SPRINGS

The following procedure applies to all of the valve springs.

1. Measure:
  - Valve spring free length "a"

Out of specification → Replace the valve spring.



**Valve spring free length**  
**Free length (intake)**  
 39.79 mm (1.57 in)  
**Limit**  
 37.80 mm (1.49 in)  
**Free length (exhaust)**  
 38.42 mm (1.51 in)  
**Limit**  
 36.50 mm (1.44 in)

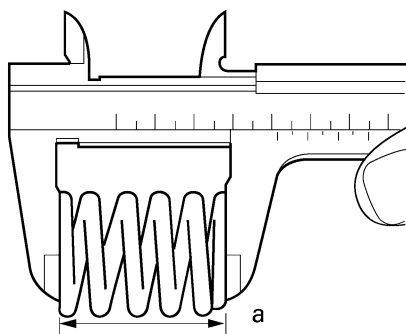

11171902

2. Measure:
  - Compressed valve spring force "a"  
 Out of specification → Replace the valve spring.



**Installed compression spring force (intake)**  
 171–197 N (38.44–44.29 lbf)  
 (17.44–20.09 kgf) at 35.50 mm  
 (1.398 in)  
**Installed compression spring force (exhaust)**  
 202–232 N (45.41–52.15 lbf)  
 (20.60–23.66 kgf) at 33.00 mm  
 (1.299 in)

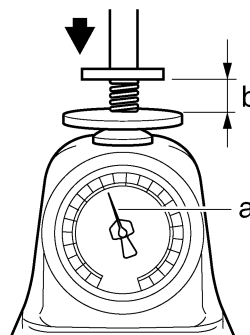

b. Installed length

## VALVES AND VALVE SPRINGS

### 3. Measure:

- Valve spring tilt "a"  
Out of specification → Replace the valve spring.

	<b>Spring tilt limit</b> <b>Spring tilt (intake)</b> 2.5 °/1.7 mm <b>Spring tilt (exhaust)</b> 2.5 °/1.7 mm
---	---

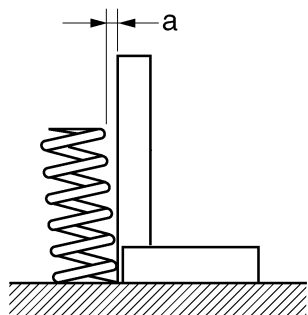

EAS24320

### CHECKING THE VALVE LIFTERS

The following procedure applies to all of the valve lifters.

#### 1. Check:

- Valve lifter  
Damage/scratches → Replace the valve lifters and cylinder head.

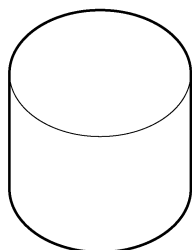

EAS24340

### INSTALLING THE VALVES

The following procedure applies to all of the valves and related components.

#### 1. Deburr:

- Valve stem end  
(with an oil stone)

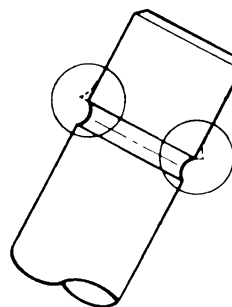

#### 2. Lubricate:

- Valve stem "1"
- Valve stem seal "2"  
(with the recommended lubricant)

	<b>Recommended lubricant</b> Molybdenum disulfide oil
---	--

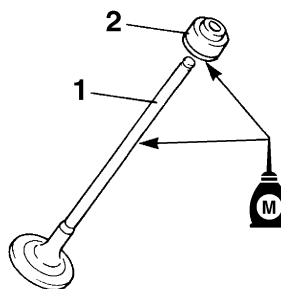

#### 3. Install:

- Valve "1"
- Lower spring seat "2"
- Valve stem seal "3"
- Valve spring "4"
- Upper spring seat "5"  
(into the cylinder head)

#### NOTE:

- Make sure each valve is installed in its original place. Refer to the following embossed marks.  
Intake valve: Pink paint mark  
Exhaust valve: "4C8"
- Install the valve springs with the larger pitch "a" facing up.

## VALVES AND VALVE SPRINGS

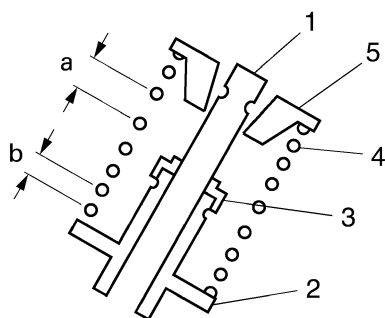

I1172001

- b. Smaller pitch
- 4. Install:
  - Valve cotters "1"

**NOTE:**

Install the valve cotters by compressing the valve spring with the valve spring compressor "2" and the valve spring compressor attachment "3".



**Valve spring compressor**  
**90890-04019**  
**YM-04019**  
**Valve spring compressor**  
**attachment**  
**90890-04108**  
**Valve spring compressor**  
**adapter 22 mm**  
**YM-04108**

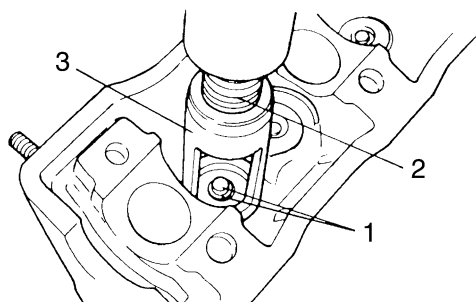

- 5. To secure the valve cotters "1" onto the valve stem, lightly tap the valve tip with a soft-face hammer.

ECA13800

**CAUTION:**

**Hitting the valve tip with excessive force could damage the valve.**

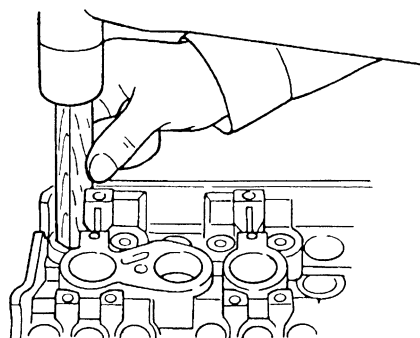

- 6. Lubricate:
  - Valve pad "1"
  - Valve lifter "2"
 (with the recommended lubricant)

	<b>Recommended lubricant</b> <b>Molybdenum disulfide oil</b>
---	---

- 7. Install:
  - Valve pad
  - Valve lifter

**NOTE:**

- The valve lifter must move smoothly when rotated with a finger.
- Each valve lifter and valve pad must be reinstalled in its original position.

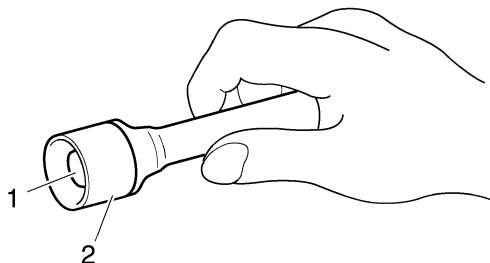

I1171102

# GENERATOR

EAS24480

## GENERATOR

### Removing the generator

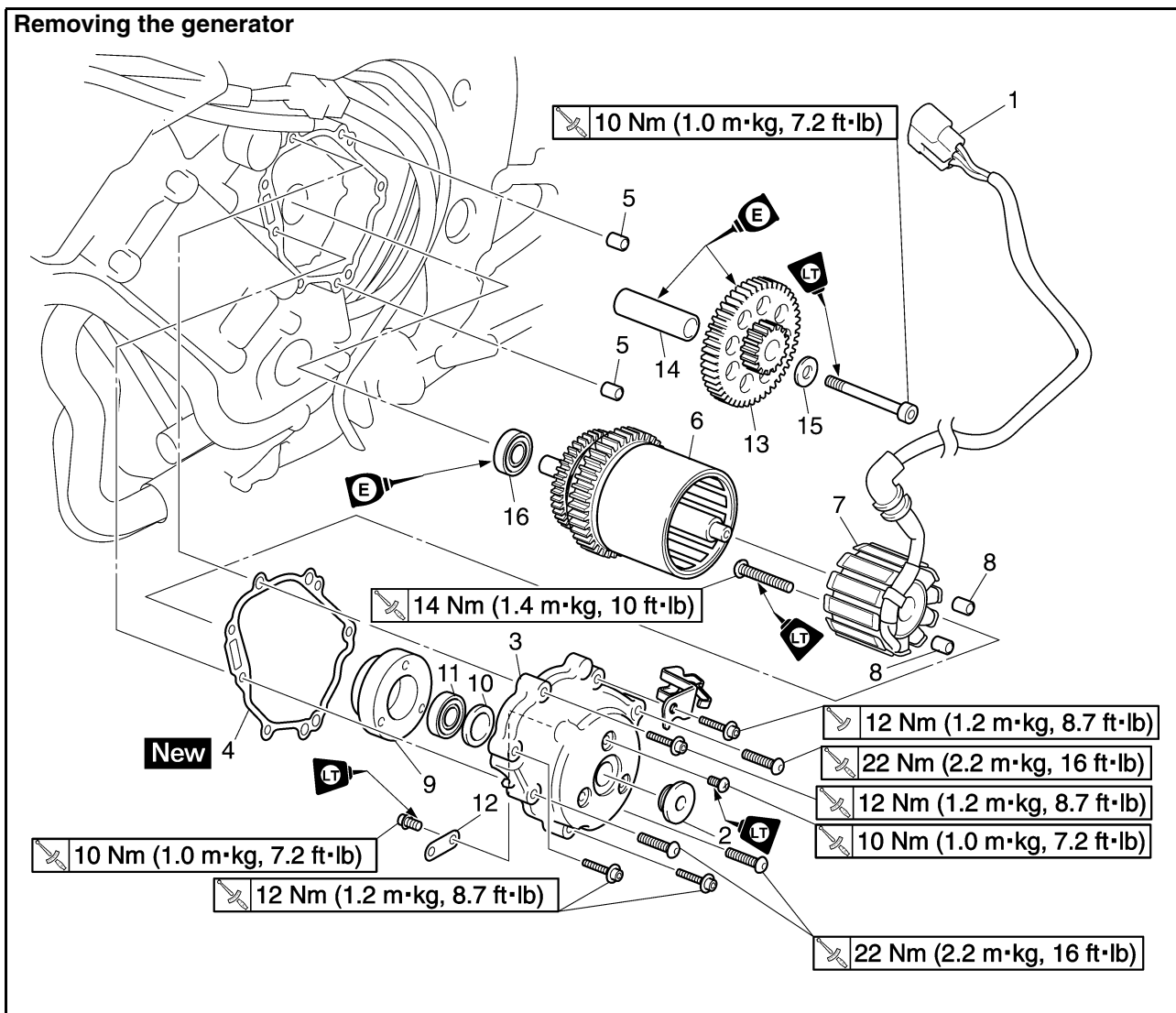

Order	Job/Parts to remove	Q'ty	Remarks
	Rider seat		Refer to "GENERAL CHASSIS" on page 4-1.
	Passenger seat		Refer to "GENERAL CHASSIS" on page 4-1.
	Side cowlings		Refer to "GENERAL CHASSIS" on page 4-1.
	Lower cowlings		Refer to "GENERAL CHASSIS" on page 4-1.
	Engine oil		Drain. Refer to "CHANGING THE ENGINE OIL" on page 3-12.
1	Stator coil assembly coupler	1	Disconnect.
2	Plug	1	
3	Generator rotor cover	1	
4	Gasket	1	
5	Dowel pin	2	
6	Generator rotor assembly	1	
7	Stator coil assembly	1	
8	Dowel pin	2	
9	Bearing housing	1	
10	Collar	1	
11	Bearing	1	

# GENERATOR

## Removing the generator

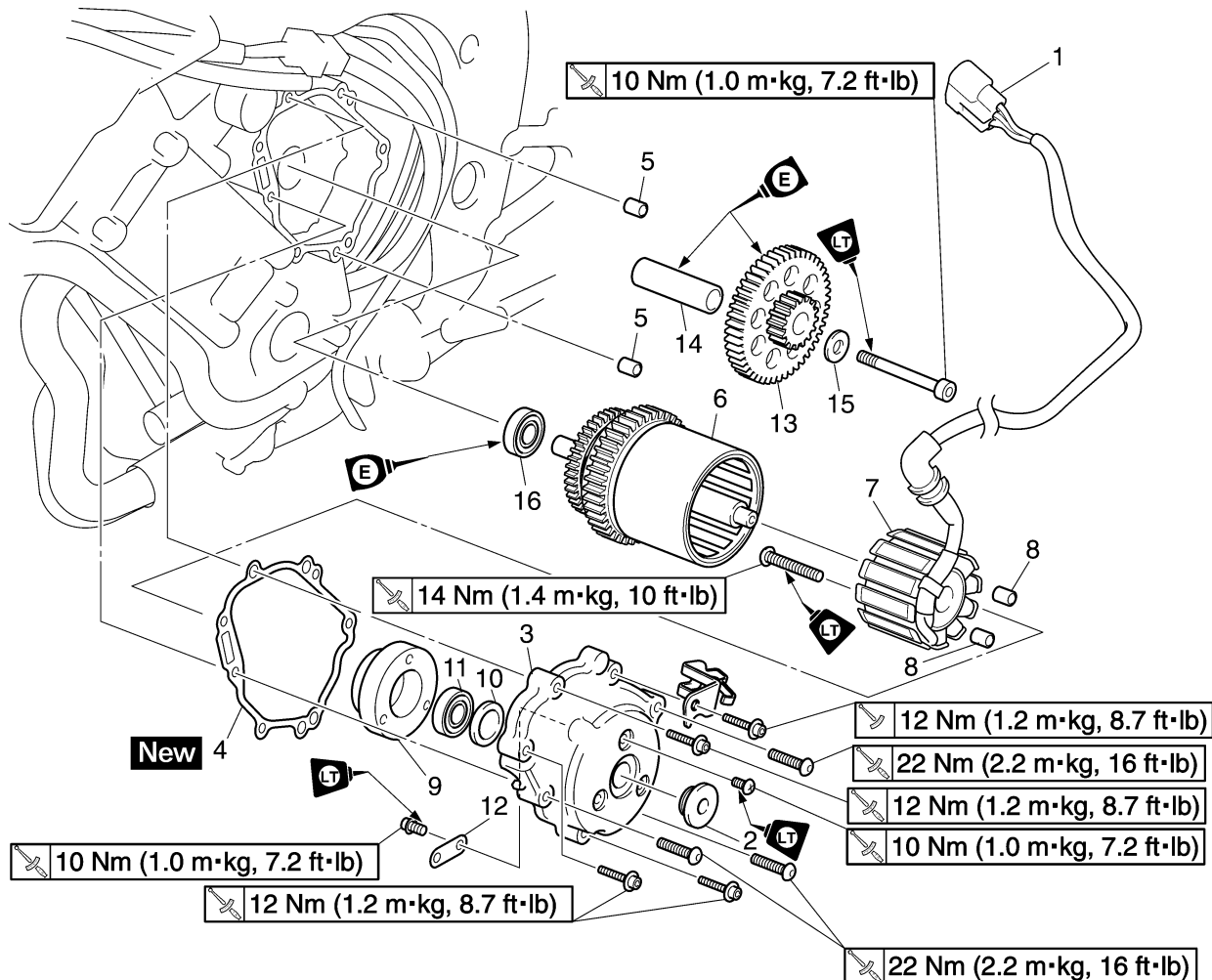

Order	Job/Parts to remove	Q'ty	Remarks
12	Stator coil assembly lead holder	1	
13	Idler gear	1	
14	Idler gear shaft	1	
15	Washer	1	
16	Bearing	1	
			For installation, reverse the removal procedure.

# GENERATOR

EAS24490

## REMOVING THE GENERATOR

1. Remove:
  - Plug
  - Generator rotor cover "1"

### NOTE:

- While pushing generator rotor, remove the generator rotor cover.
- Loosen each bolt 1/4 of a turn a time, in stages and in a crisscross pattern.
- After all of the bolts are fully loosened, remove them.

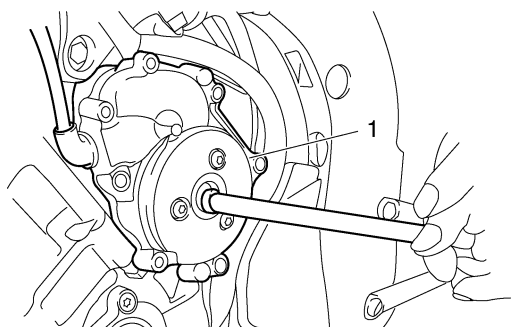

2. Remove:
  - Generator rotor and starter clutch assembly "1"

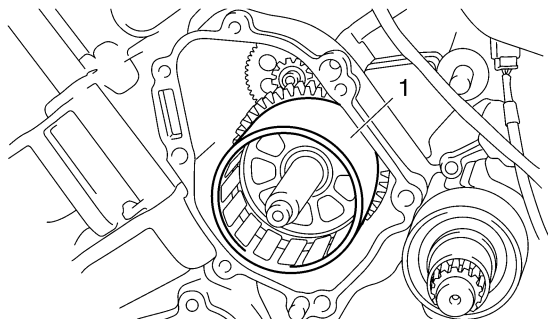

3. Remove:
  - Idle gear shaft bolt "1"
  - Idle shaft
  - Idle gear "2"

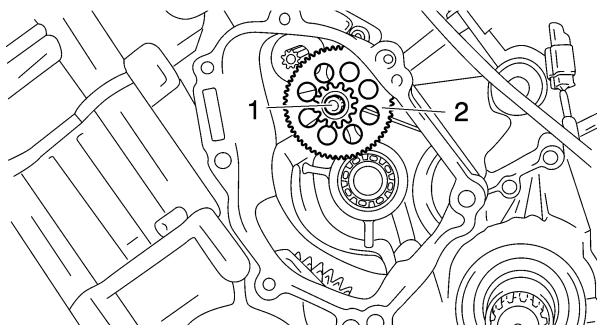

EAS24500

## INSTALLING THE GENERATOR

1. Install:
  - Idle gear shaft
  - Idle gear "1"
  - Washer
  - Idle gear shaft bolt "2"



**Idle gear shaft bolt**  
**10 Nm (1.0 m·kg, 7.2 ft·lb)**  
**LOCTITE®**

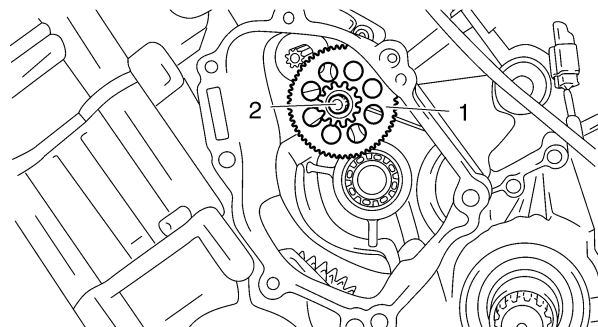

2. Install
  - Generator rotor and starter clutch assembly "1"

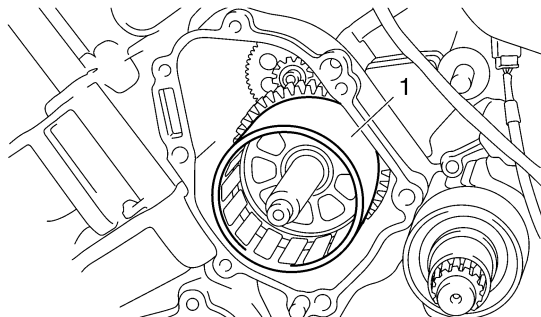

3. Install:
  - Generator rotor cover gasket **New**
  - Generator rotor cover "1"



**Generator rotor cover bolt (M6)**  
**12 Nm (1.2 m·kg, 8.7 ft·lb)**  
**Generator rotor cover bolt (M8)**  
**22 Nm (2.2 m·kg, 16 ft·lb)**

## GENERATOR

---

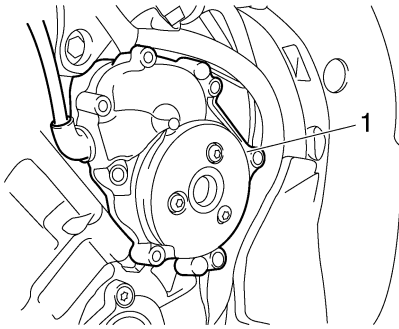

**NOTE:**

---

- First tighten the M8 bolts and then tighten the M6 bolts.
  - Tighten the generator rotor cover bolts in stages and in a crisscross pattern.
-

# STARTER CLUTCH

EAS24550

## STARTER CLUTCH

### Removing the starter clutch

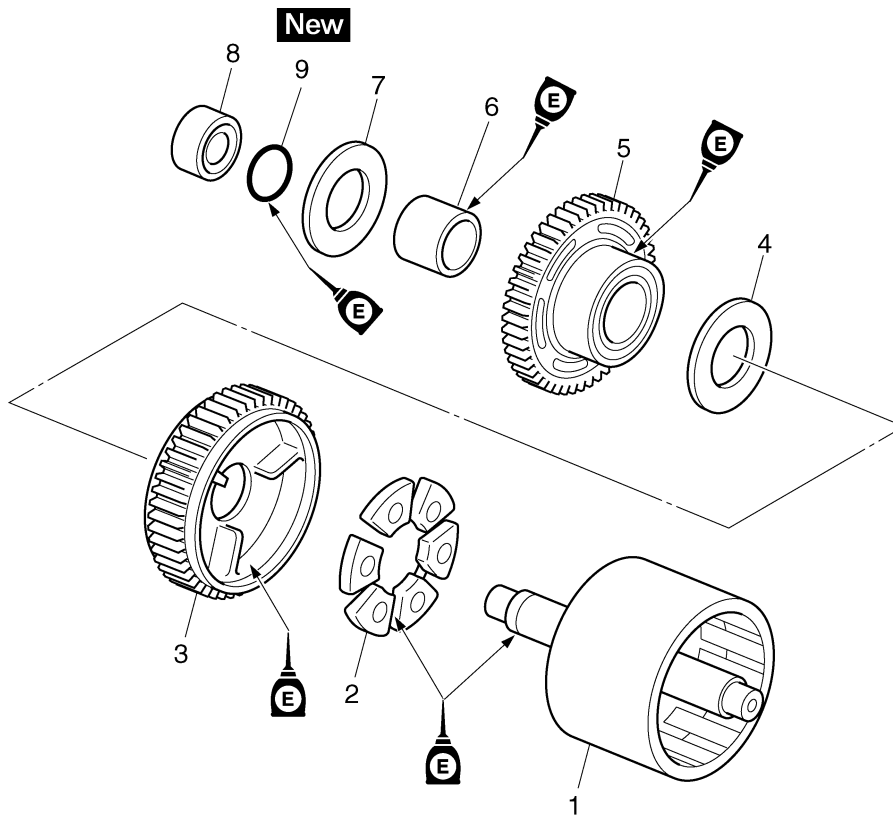

Order	Job/Parts to remove	Q'ty	Remarks
1	Generator rotor	1	
2	Damper	3	
3	Driven gear	1	
4	Washer	1	
5	Starter clutch drive gear	1	
6	Collar	1	
7	Washer	1	
8	Spacer	1	
9	O-ring	1	
			For assembly, reverse the removal procedure.



## STARTER CLUTCH

- b. When turning the starter clutch drive gear clockwise "A", the starter clutch and the starter clutch drive gear should engage, otherwise the starter clutch is faulty and must be replaced.
- c. When turning the starter clutch drive gear counterclockwise "B", it should turn freely, otherwise the starter clutch is faulty and must be replaced.

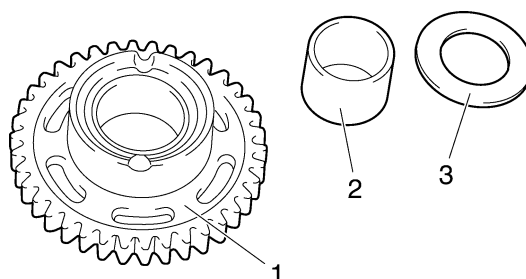
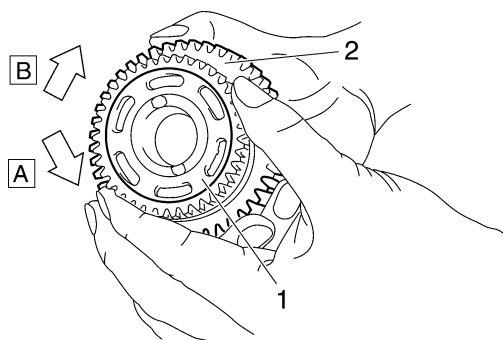

3. Install:
  - Washer "1"
  - O-ring "2" **New**
  - Spacer "3"

**NOTE:** \_\_\_\_\_  
Lubricate the engine oil to O-ring.



EAS24600

### INSTALLING THE STARTER CLUTCH

1. Install:
  - Generator rotor "1"
  - Damper "2"
  - Driven gear "3"

**NOTE:** \_\_\_\_\_  
• The hole side of the damper is installed to the generator side.  
• Lubricate the engine oil "4".

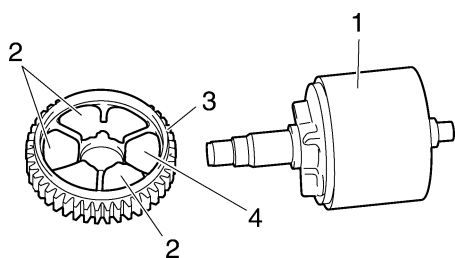
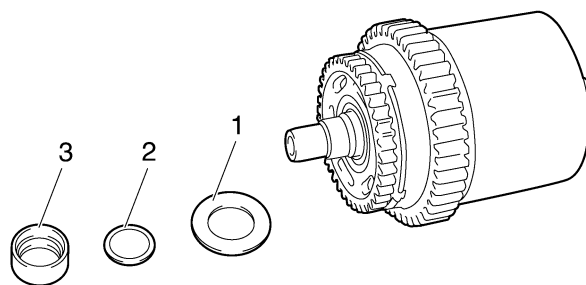

2. Install
  - Starter clutch drive gear "1"
  - Collar "2"
  - Washer "3"
 Refer to "CHECKING THE STARTER CLUTCH" on page 5-35.

# CRANKSHAFT POSITION SENSOR

EAS24520

## CRANKSHAFT POSITION SENSOR

### Removing the crankshaft position sensor

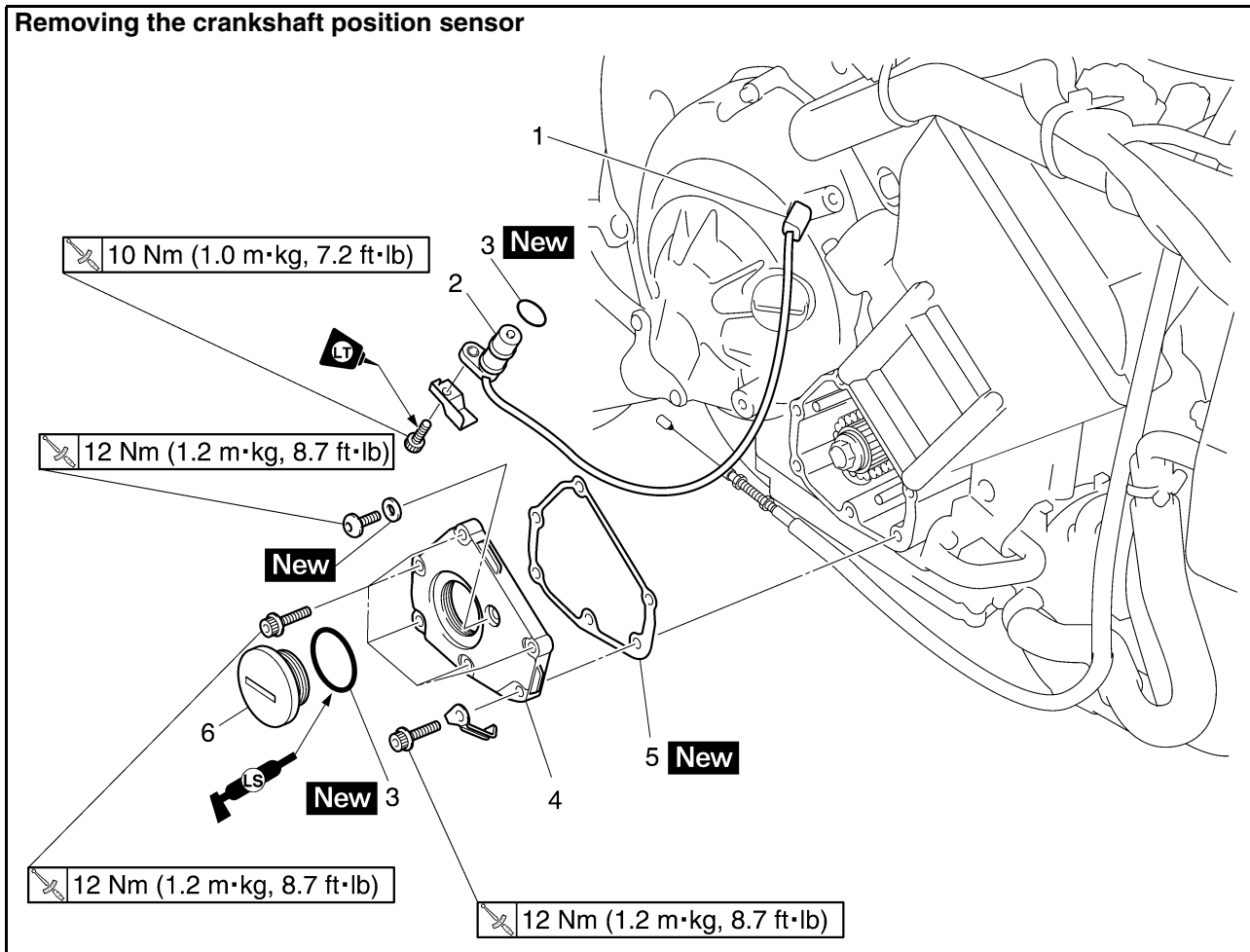

Order	Job/Parts to remove	Q'ty	Remarks
	Rider seat		Refer to "GENERAL CHASSIS" on page 4-1.
	Side cowlings		Refer to "GENERAL CHASSIS" on page 4-1.
	Lower cowlings		Refer to "GENERAL CHASSIS" on page 4-1.
	Fuel tank		Refer to "FUEL TANK" on page 7-1.
	Engine oil		Drain. Refer to "CHANGING THE ENGINE OIL" on page 3-12.
1	Crankshaft position sensor lead coupler	1	
2	Crankshaft position sensor	1	
3	O-ring	1	
4	Pickup rotor cover	1	
5	Gasket	1	
6	Cover	1	
			For installation, reverse the removal procedure.

## CRANKSHAFT POSITION SENSOR

EAS24530

### REMOVING THE CRANKSHAFT POSITION SENSOR

1. Disconnect:
  - Crankshaft position sensor lead coupler
2. Remove:
  - Crankshaft position sensor
  - O-ring
  - Pickup coil rotor cover "1"

#### NOTE:

Loosen each bolt 1/4 of a turn at a time, in stages and in a crisscross pattern.  
After all of the bolts are fully loosened, remove them.

- Crankshaft position sensor lead coupler

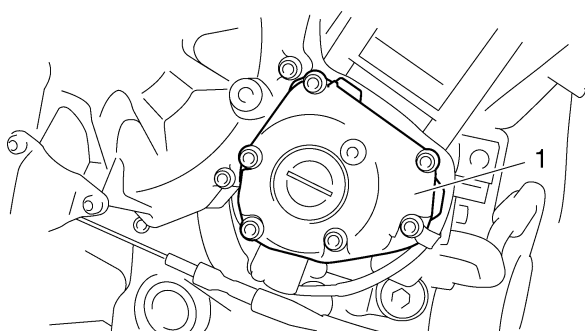

EAS24540

### INSTALLING THE CRANKSHAFT POSITION SENSOR

1. Install:
  - Gasket **New**
  - Pickup rotor cover "1"

	<b>Pickup rotor cover</b> <b>12 Nm (1.2 m·kg, 8.7 ft·lb)</b>
---	---

- O-ring **New**
- Crankshaft position sensor

	<b>Crankshaft position sensor bolt</b> <b>10 Nm (1.0 m·kg, 7.2 ft·lb)</b> <b>LOCTITE®</b>
---	---

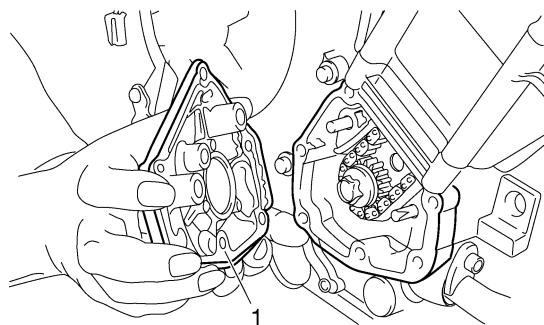

2. Connect

# ELECTRIC STARTER

EAS24780

## ELECTRIC STARTER

### Removing the starter motor

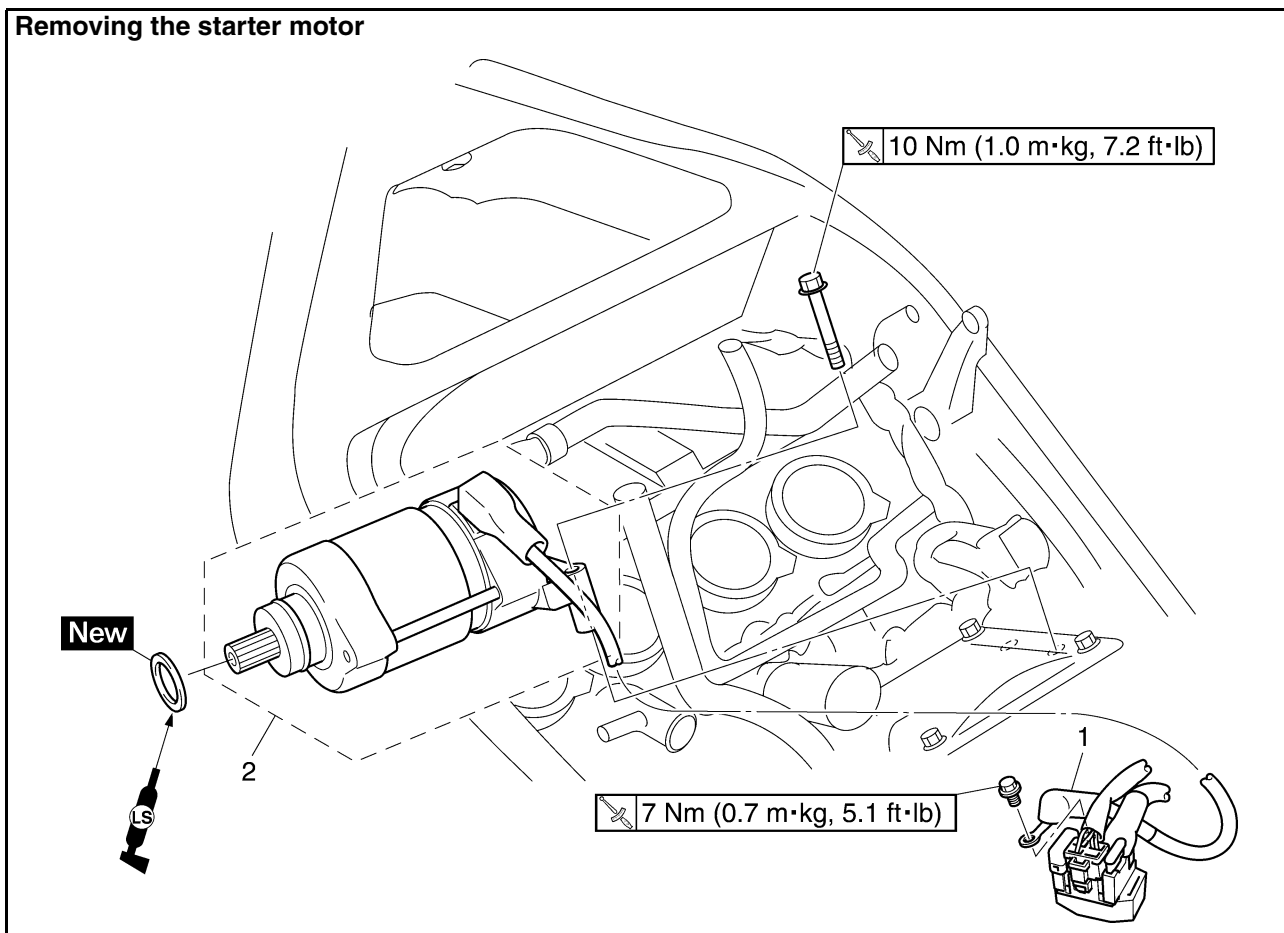

Order	Job/Parts to remove	Q'ty	Remarks
	Rider seat		Refer to "GENERAL CHASSIS" on page 4-1.
	Fuel tank		Refer to "FUEL TANK" on page 7-1.
	Air filter case		Refer to "GENERAL CHASSIS" on page 4-1.
	Throttle body		Refer to "THROTTLE BODIES" on page 7-4.
1	Starter motor lead	1	Disconnect.
2	Starter motor	1	
			For installation, reverse the removal procedure.

# ELECTRIC STARTER

## Disassembling the starter motor

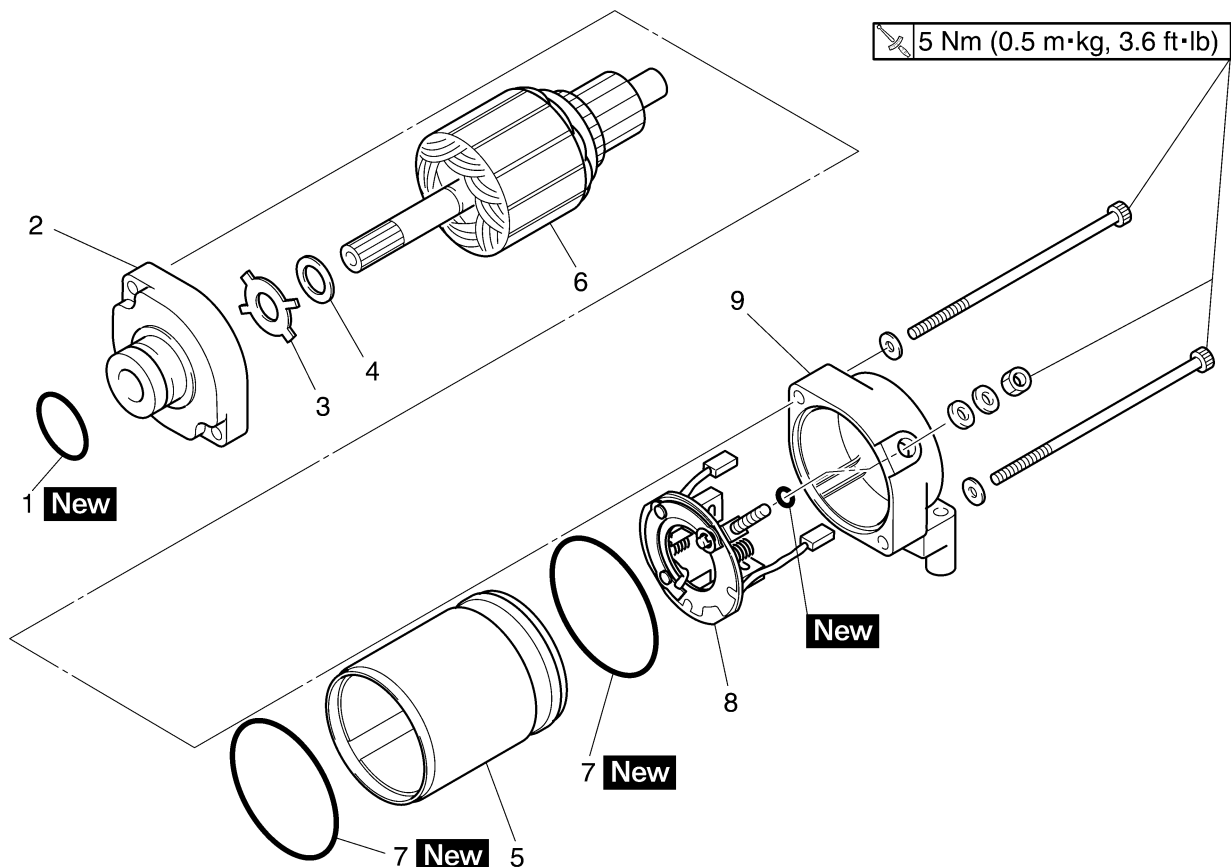

Order	Job/Parts to remove	Q'ty	Remarks
1	O-ring	1	
2	Front cover	1	
3	Lock washer	1	
4	Washer	1	
5	Starter motor yoke	1	
6	Armature assembly	1	
7	Gasket	2	
8	Brush holder	1	
9	Rear cover	1	
			For assembly, reverse the removal procedure.



# ELECTRIC STARTER

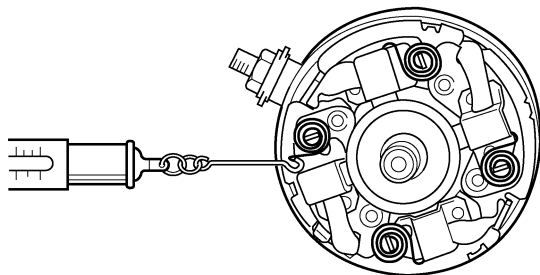

7. Check:
- Gear teeth
- Damage/wear → Replace the starter motor.

EAS24800

## ASSEMBLING THE STARTER MOTOR

1. Install:
- Brush holder
  - Armature

- a. Pull both the brush spring "1" and the brush "2" outside and hook the brush spring to the groove portion at the side of the brush.

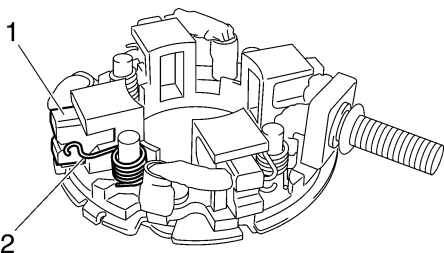

- b. Insert the armature "3" into the brush holder "4" and push the brush "5" inside until it touches the armature.

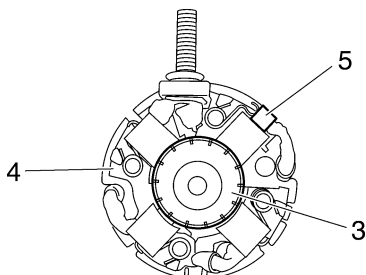

2. Install:
- O-rings **New**
  - Rear cover "1"

**NOTE:**  
Align the tab "a" on the brush holder "2" with the tab "b" in the starter motor rear cover.

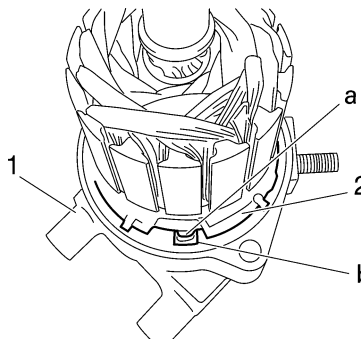

3. Install:
- Nut "1"

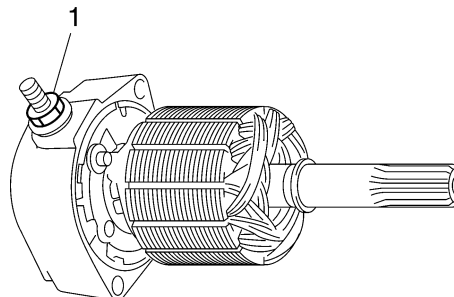
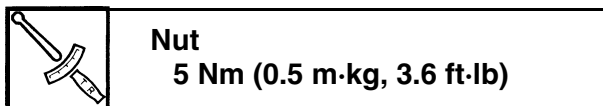

4. Install:
- Starter motor yoke "1"
  - Gasket "2" **New**
  - Starter motor rear cover "3"
  - Starter motor assembling bolts "4"

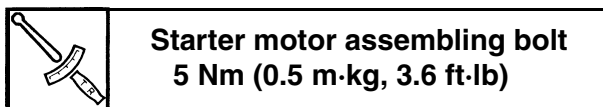

**NOTE:**  
Align the match marks "a" on the starter motor yoke with the match marks "b" on the front and starter motor rear covers.

# ELECTRIC STARTER

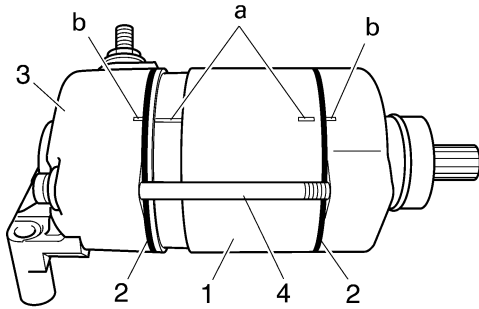

EAS24810

## INSTALLING THE STARTER MOTOR

1. Install:

- Starter motor "1"
- Starter motor bolts "2"

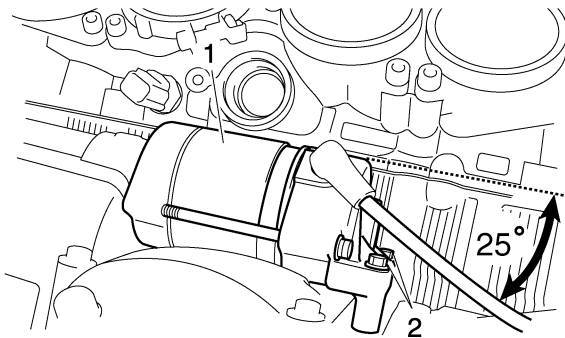
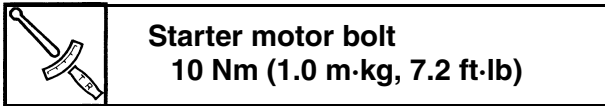

2. Connect:

- Starter motor lead "3"

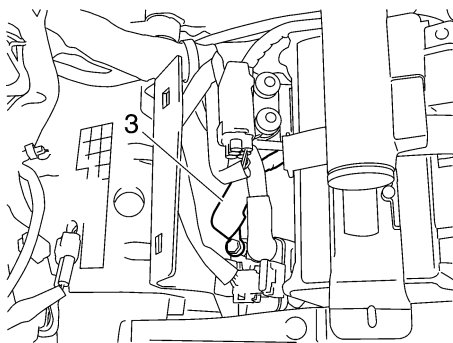
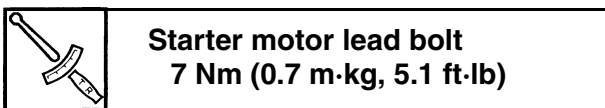

# CLUTCH

EAS25060

## CLUTCH

### Removing the clutch cover

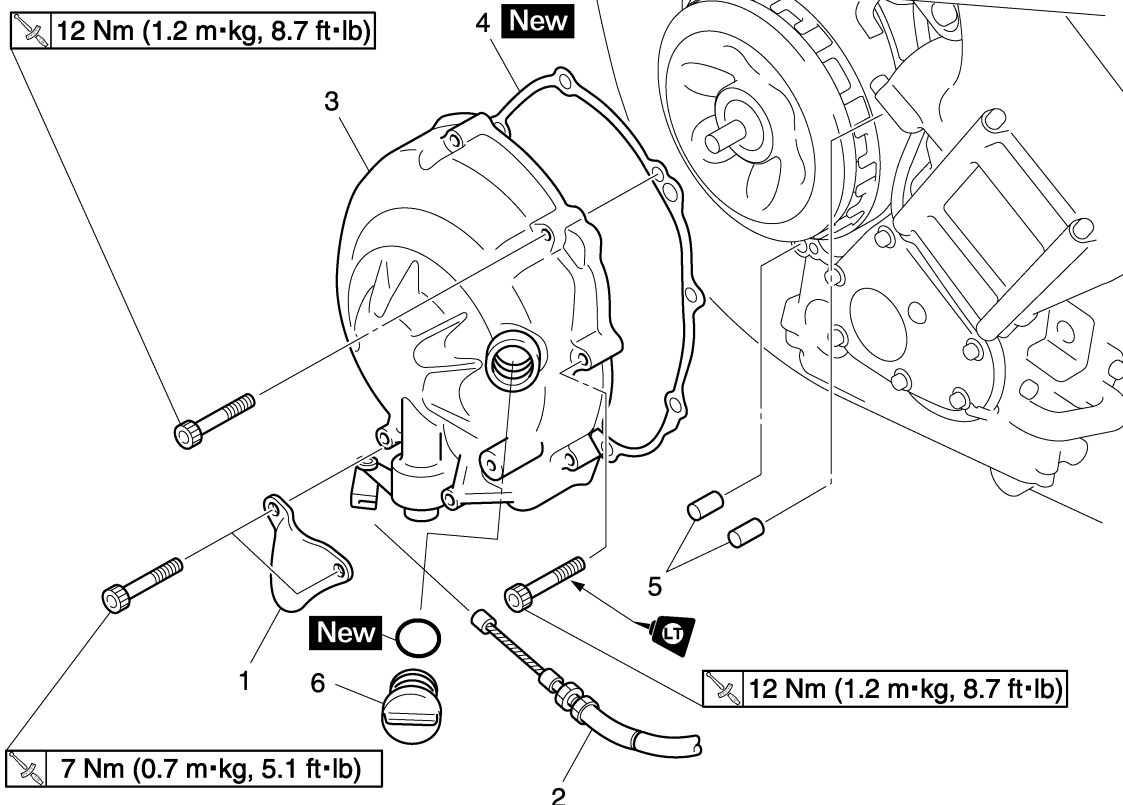

Order	Job/Parts to remove	Q'ty	Remarks
	Right side cowling		Refer to "GENERAL CHASSIS" on page 4-1.
	Bottom cowlings		Refer to "GENERAL CHASSIS" on page 4-1.
	Engine oil		Drain. Refer to "CHANGING THE ENGINE OIL" on page 3-12.
1	Cover	1	
2	Clutch cable	1	Disconnect.
3	Clutch cover	1	
4	Clutch cover gasket	1	
5	Dowel pin	2	
6	Oil filler cap	1	
			For installation, reverse the removal procedure.

# CLUTCH

## Removing the push lever shaft

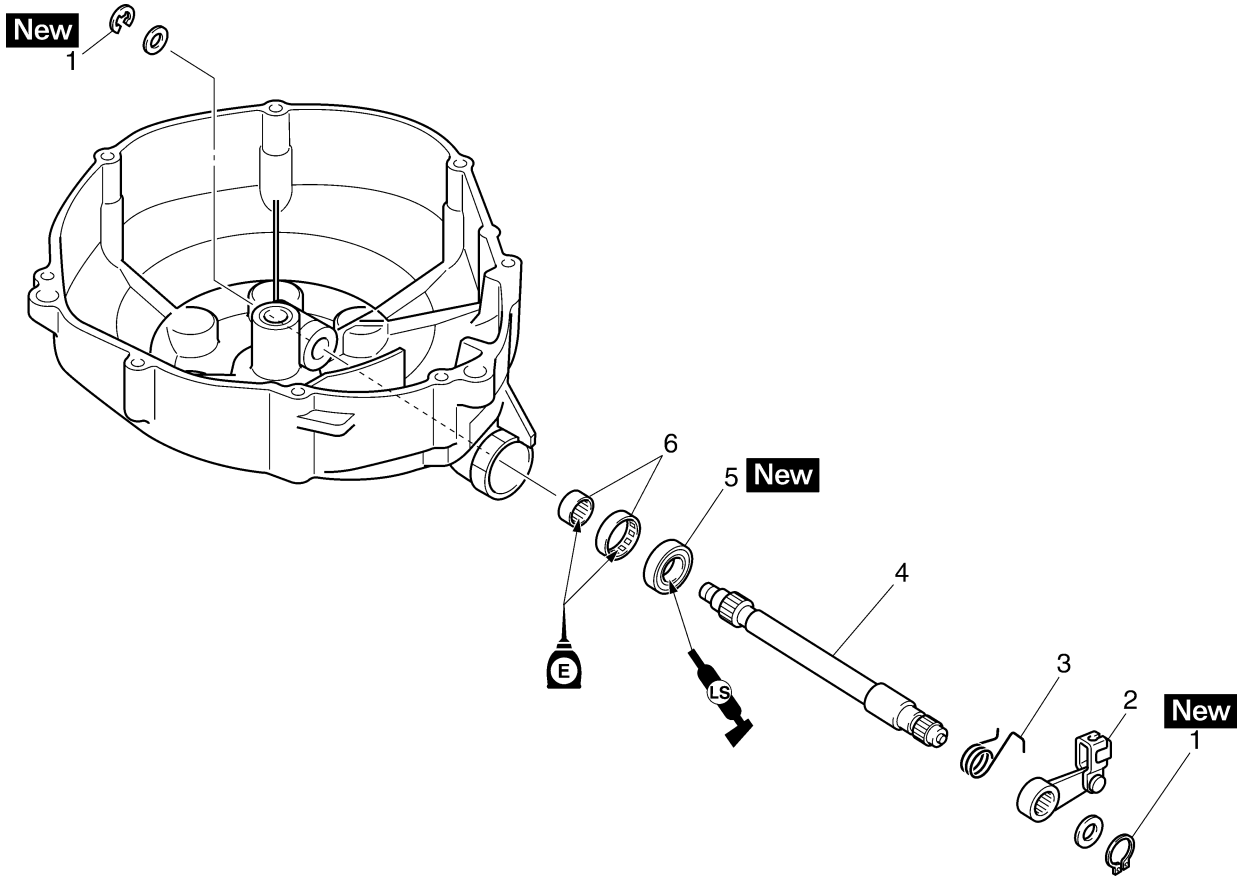

Order	Job/Parts to remove	Q'ty	Remarks
1	Circlip	2	
2	Pull lever	1	
3	Pull lever spring	1	
4	Pull lever shaft	1	
5	Oil seal	1	
6	Bearing	2	
			For installation, reverse the removal procedure.

# CLUTCH

## Removing the clutch

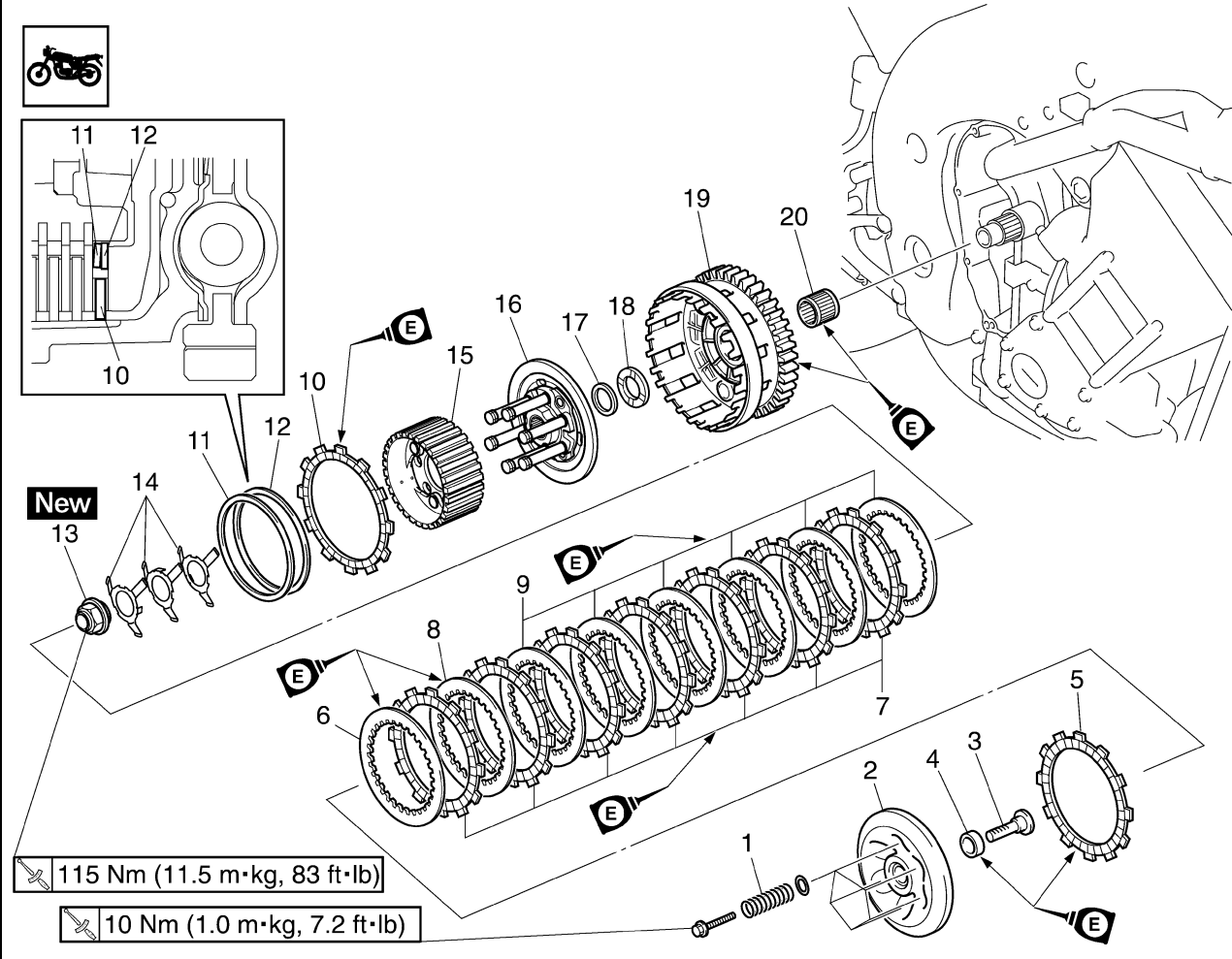

Order	Job/Parts to remove	Q'ty	Remarks
1	Compression spring	6	
2	Pressure plate 1	1	
3	Push rod	1	
4	Bearing	1	
5	Friction plate 1	1	
6	Clutch plate 1	1	
7	Friction plate 2	7	
8	Clutch plate 2	1	
9	Clutch plate 3	6	
10	Friction plate 3	1	
11	Clutch damper spring	1	
12	Clutch damper spring seat	1	
13	Muffler	1	
14	Spring	3	
15	Clutch boss	1	
16	Pressure plate 2	1	
17	Conical spring washer	1	
18	Thrust plate 2	1	
19	Clutch housing	1	
20	Bearing	1	
			For installation, reverse the removal procedure.

# CLUTCH

EAS25080

## REMOVING THE CLUTCH

1. Remove:
  - Clutch cover "1"
  - Gasket

**NOTE:**

Loosen each bolt 1/4 of a turn at a time, in stages and in a crisscross pattern. After all of the bolts are fully loosened, remove them.

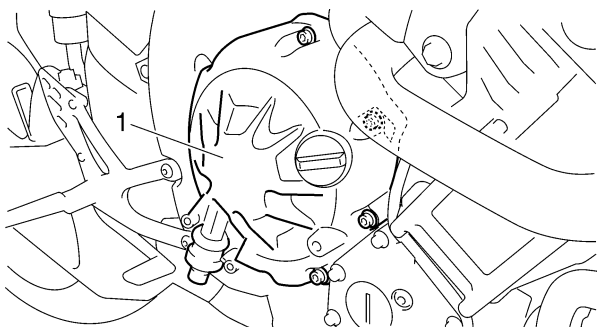

2. Remove:
  - Compression spring bolts "1"
  - Compression springs
  - Pressure plate "2"
  - Push rod "3"

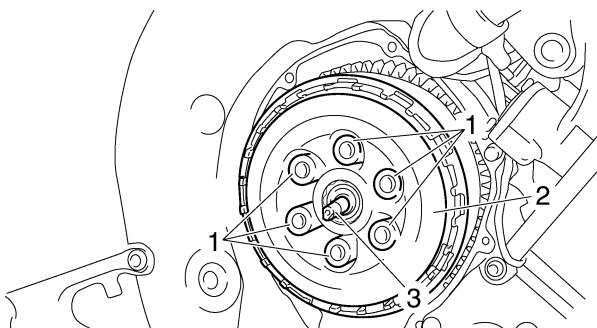

3. Remove:
  - Friction plate 1 "1"

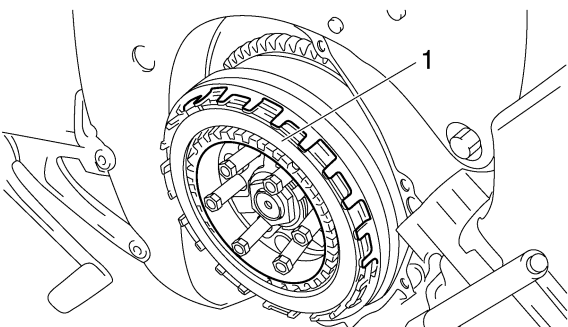

4. Remove:
  - Clutch plate 1 "1"

- Friction plate 2
- Clutch plate 2
- Clutch plate 3
- Friction plate 3
- Clutch damper spring
- Clutch damper spring seat

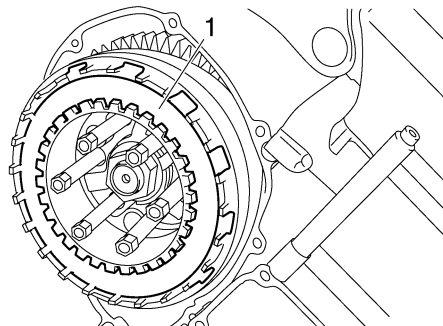

5. Straighten the clutch boss nut rib "1".

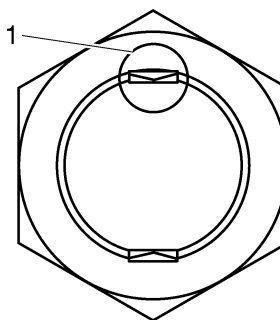

6. Loosen:
  - Clutch boss nut "1"

**NOTE:**

While holding the clutch boss "2" with the universal clutch holder "3", loosen the clutch boss nut.



**Universal clutch holder**  
**90890-04086**  
**YM-91042**

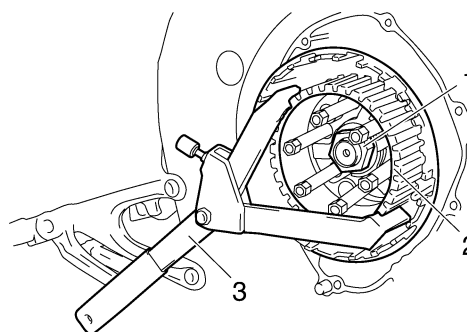

7. Remove:
  - Clutch boss nut

# CLUTCH

- Springs
- Pressure plate 2
- Conical spring washer
- Thrust plate 2

EAS25100

### CHECKING THE FRICTION PLATES

The following procedure applies to all of the friction plates.

1. Check:
  - Friction plate  
Damage/wear → Replace the friction plates as a set.
2. Measure:
  - Friction plate thickness  
Out of specification → Replace the friction plates as a set.

**NOTE:**

Measure the friction plate at four places.



**Friction plate thickness**  
2.90–3.10 mm (0.114–0.122 in)  
**Wear limit**  
2.80 mm (0.1102 in)

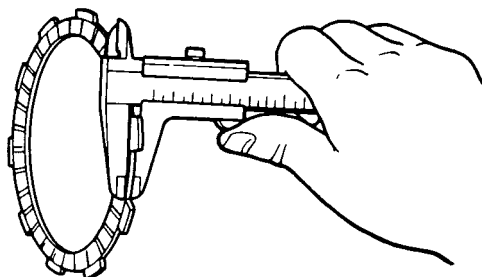

EAS25110

### CHECKING THE CLUTCH PLATES

The following procedure applies to all of the clutch plates.

1. Check:
  - Clutch plate  
Damage → Replace the clutch plates as a set.
2. Measure:
  - Clutch plate warpage  
(with a surface plate and thickness gauge “1”)  
Out of specification → Replace the clutch plates as a set.



**Warpage limit**  
0.10 mm (0.0039 in)

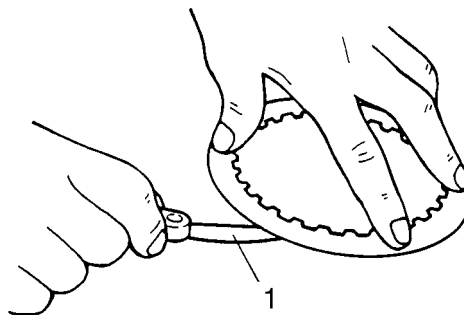

3. Measure:
  - assembly width “a” of the friction plates and clutch plates  
Out of specification → Adjust.



**Assembly width**  
42.4–43.0 mm (1.67–1.69 in)

**NOTE:**

Perform the thickness measurement without applying the oil.

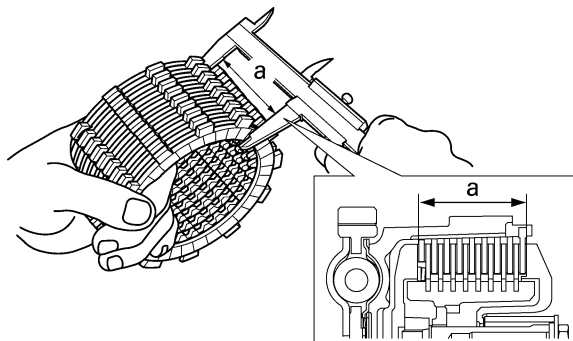

- Assembly width adjusted by clutch plate “1” and “2”.
- Select the clutch plate from the following table.

**Clutch plate “1”**

Part No.	Thickness	
4B1-16324-00	1.6 mm (0.062 in)	
5VY-16325-00	2.0 mm (0.079 in)	STD
4B1-16325-00	2.3 mm (0.091 in)	

# CLUTCH

## Clutch plate "2"

Part No.	Thickness	
5VY-16325-00	2.0 mm (0.079 in)	STD
4B1-16325-00	2.3 mm (0.091 in)	

**NOTE:**

When adjusting the clutch assembly width [by replacing the clutch plate(s)], be sure to replace the clutch plate "1" first. After replacing the clutch plate "1", if specifications cannot be met, replace the clutch plate "2".

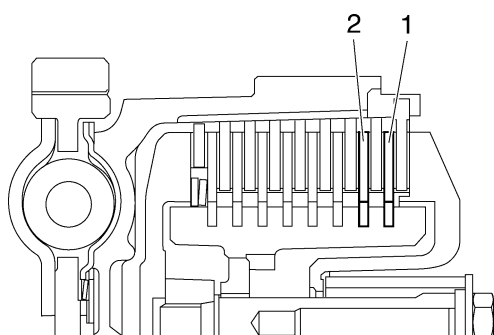

EAS25140

### CHECKING THE CLUTCH SPRINGS

The following procedure applies to all of the clutch springs.

1. Check:
  - Clutch spring  
Damage → Replace the clutch springs as a set.
2. Measure:
  - Clutch spring free length "a"  
Out of specification → Replace the clutch springs as a set.

	<b>Clutch spring free length</b>
	<b>43.80 mm (1.72 in)</b>
	<b>Limit</b>
	<b>41.61 mm (1.64 in)</b>

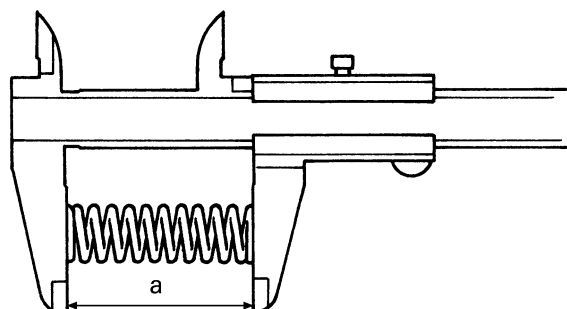

EAS25150

### CHECKING THE CLUTCH HOUSING

1. Check:
  - Clutch housing dogs  
Damage/pitting/wear → Deburr the clutch housing dogs or replace the clutch housing.

**NOTE:**

Pitting on the clutch housing dogs will cause erratic clutch operation.

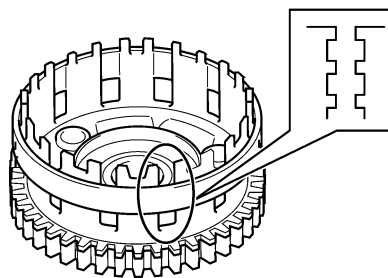

2. Check:
  - Bearing  
Damage/wear → Replace the bearing and clutch housing.

EAS25160

### CHECKING THE CLUTCH BOSS

1. Check:
  - Clutch boss splines  
Damage/pitting/wear → Replace the clutch boss.

**NOTE:**

Pitting on the clutch boss splines will cause erratic clutch operation.

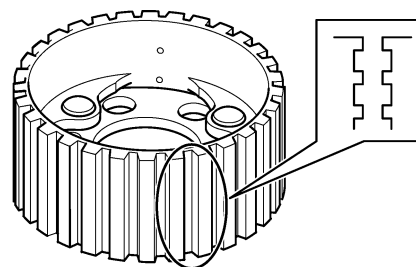

2. Check:
  - Clutch boss  
Cracks/damage → Replace.

# CLUTCH

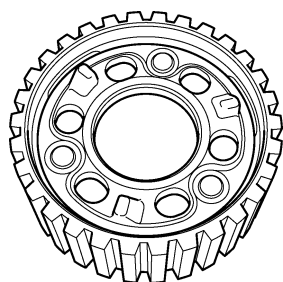

EAS4C81005

## CHECKING THE PRESSUR PLATE 2

1. Check:
  - Pressure plate 2
  - Cracks / damage → Replace.

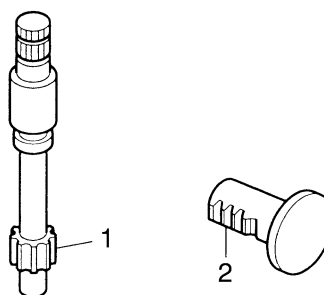

11412102

2. Check:
  - Push rod bearing
  - Damage/wear → Replace.

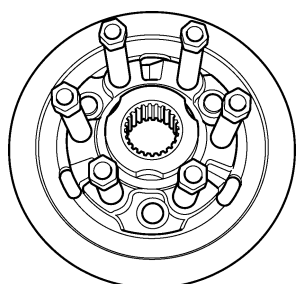

EAS25170

## CHECKING THE PRESSURE PLATE 1

1. Check:
  - Pressure plate "1"
  - Cracks/damage → Replace.
  - Bearing "2"
  - Damage/wear → Replace.

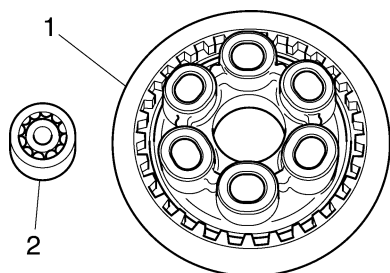

EAS25240

## INSTALLING THE CLUTCH

1. Install:
  - Clutch housing "1"
  - Conical spring washer
  - Thrust plate 2

**NOTE:** \_\_\_\_\_  
Align the projection of clutch housing "a" and hollow of the oil pump drive gear "b".

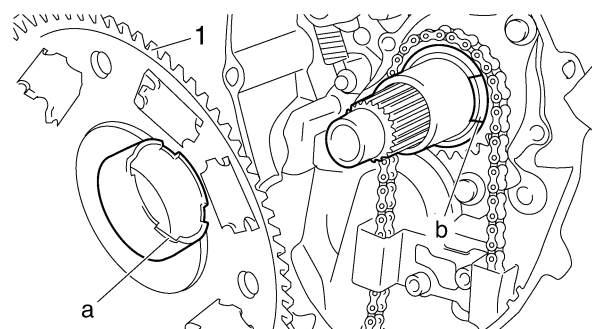

EAS4C81006

## CHECKING THE PUSH LEVER SHAFT AND PUSH ROD

1. Check:
  - Push lever shaft pinion gear teeth "1"
  - Push rod teeth "2"
  - Damage/wear → Replace the push rod and push lever shaft pinion gear as a set.

2. Install:
  - Pressure plate 2 "1"
  - Clutch boss "2"

**NOTE:** \_\_\_\_\_  
Fit the groove "a" of the pressure plate 2 to the projection "b" of the clutch boss to assemble.

# CLUTCH

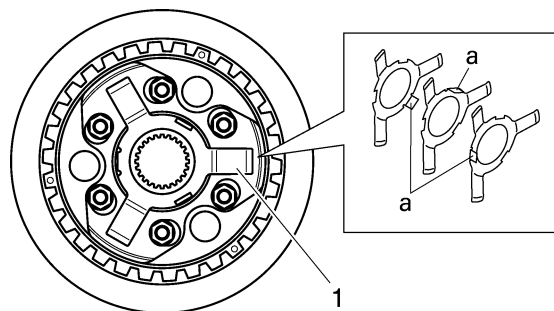
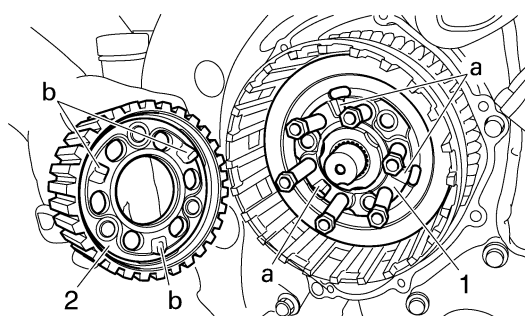

3. Install:
- Spring "1"
  - Clutch boss nut "2" **New**

	<p><b>Clutch boss nut</b>  <b>115 Nm (11.5 m·kg, 83 ft·lb)</b></p>
---	--

- NOTE:**
- Put the spring detent "a" into the groove of the pressure plate 2. Assemble so that each spring detent "a" is positioned in a different groove.
  - While holding the clutch boss "3" with the clutch holding tool "4", tighten the clutch boss nut.
  - Lock the threads on the clutch boss nut by staking them with a drift punch at the point aligned with the groove in the axle.

	<p><b>Universal clutch holder</b>  <b>90890-04086</b>  <b>YM-91042</b></p>
---	--

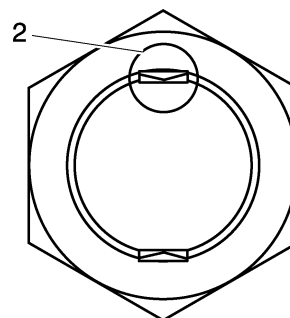
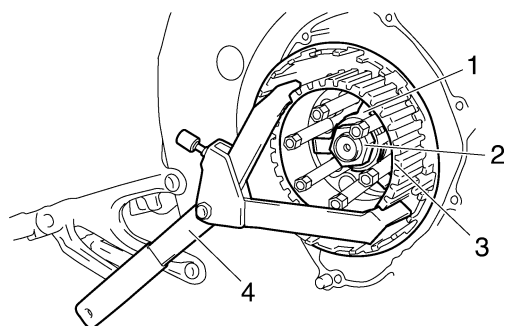

4. Install:
- Clutch damper spring seat "1"
  - Clutch damper spring "2"

**NOTE:** Install the clutch damper spring as shown in the illustration.

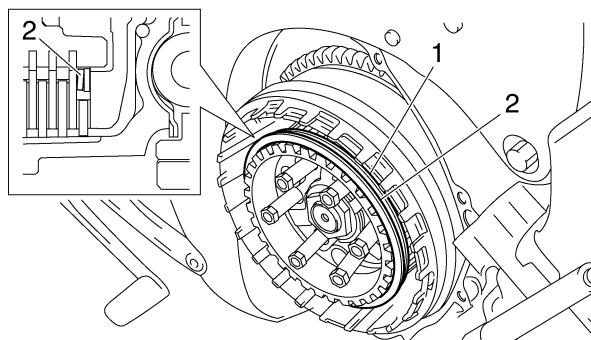

5. Lubricate:
- Friction plates
  - Clutch plates
- (with the recommended lubricant)

	<p><b>Recommended lubricant</b>  <b>Engine oil</b></p>
---	--

6. Install:
- Friction plate 3
  - Friction plate 2
  - Clutch plate 3
  - Clutch plate 2
  - Clutch plate 1 "1"

# CLUTCH

**NOTE:**  
Assemble the friction plates and clutch plates according to the installation order.

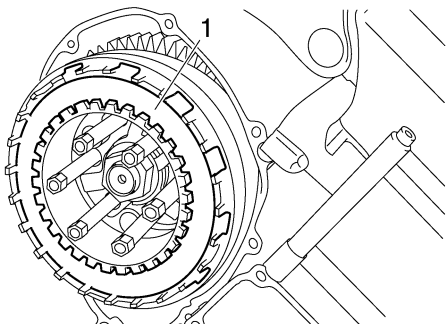

7. Install:
- Friction plate 1 "1"

**NOTE:**  
Install the last friction plate shifting half phase with the  $\varnothing 2$  punch mark "2".

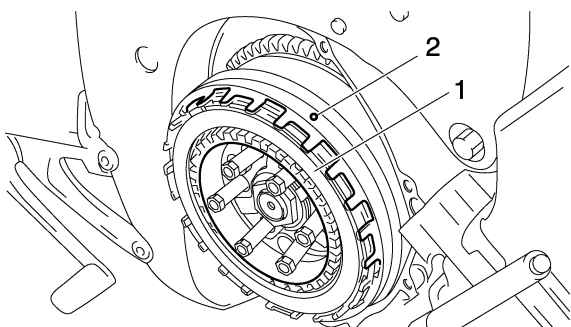

8. Install:
- Bearing
  - Pull rod
  - Pressure plate 1 "1"

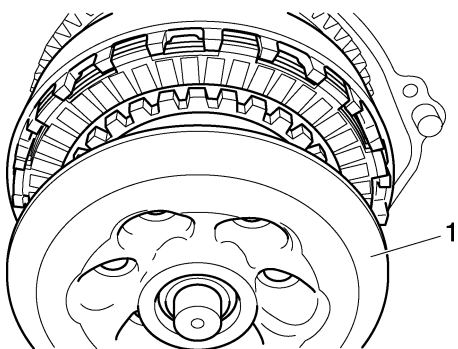

9. Install:
- Clutch springs
  - Clutch spring bolts "1"



**Clutch spring bolt**  
**10 Nm (1.0 m·kg, 7.2 ft·lb)**

**NOTE:**  
Tighten the clutch spring bolts in stages and in a crisscross pattern.

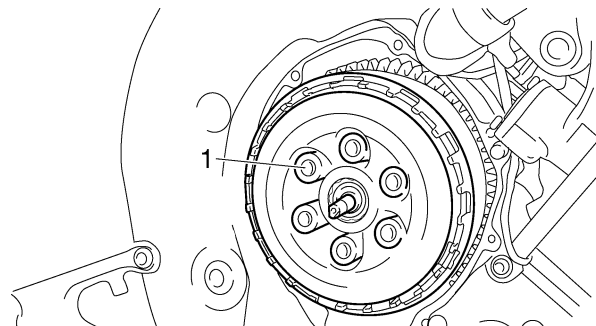

10. Install:
- Push lever

**NOTE:**  
Install the push lever with the "h" mark facing toward upper side.

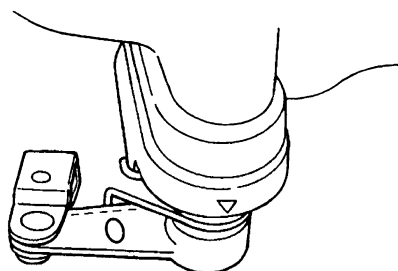

11. Install:
- Clutch cover
  - Clutch cover gasket

**NOTE:**

- Install the push rod so that the teeth a face towards the rear of the vehicle. Then, install the clutch cover.
- Apply oil onto the bearing.
- Apply molybdenum disulfide grease onto the push rod.
- When installing the clutch cover, push the push lever and check that the punch mark "a" on the push lever aligns with the mark "b" on the clutch cover. Make sure that the push rod teeth and push lever shaft pinion gear are engaged.

# CLUTCH

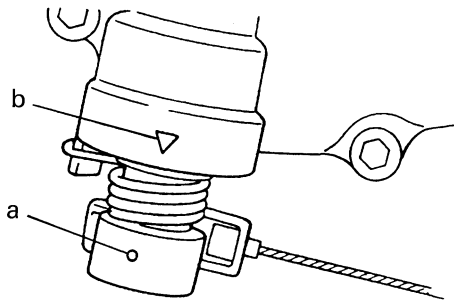

12. Tighten:

- Clutch cover bolts "1"
- Clutch cover bolt "2"

	<b>Clutch cover bolt</b> <b>12 Nm (1.2 m·kg, 8.7 ft·lb)</b>
	<b>Clutch cover bolt</b> <b>12 Nm (1.2 m·kg, 8.7 ft·lb)</b> <b>LOCTITE®</b>

**NOTE:** \_\_\_\_\_

Tighten the clutch cover bolts in a stages and in a crisscross pattern.

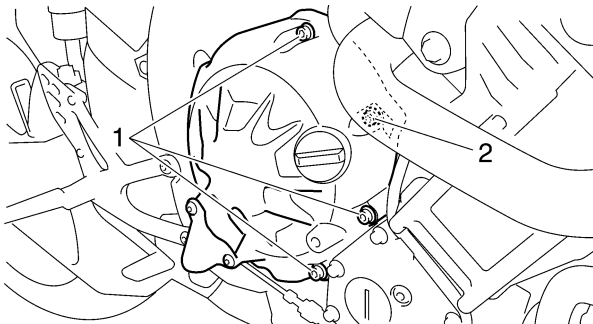

13. Adjust:

- Clutch cable free play  
Refer to "ADJUSTING THE CLUTCH CABLE FREE PLAY" on page 3-14.

# SHIFT SHAFT

EAS25410

## SHIFT SHAFT

### Removing the shift shaft and stopper lever

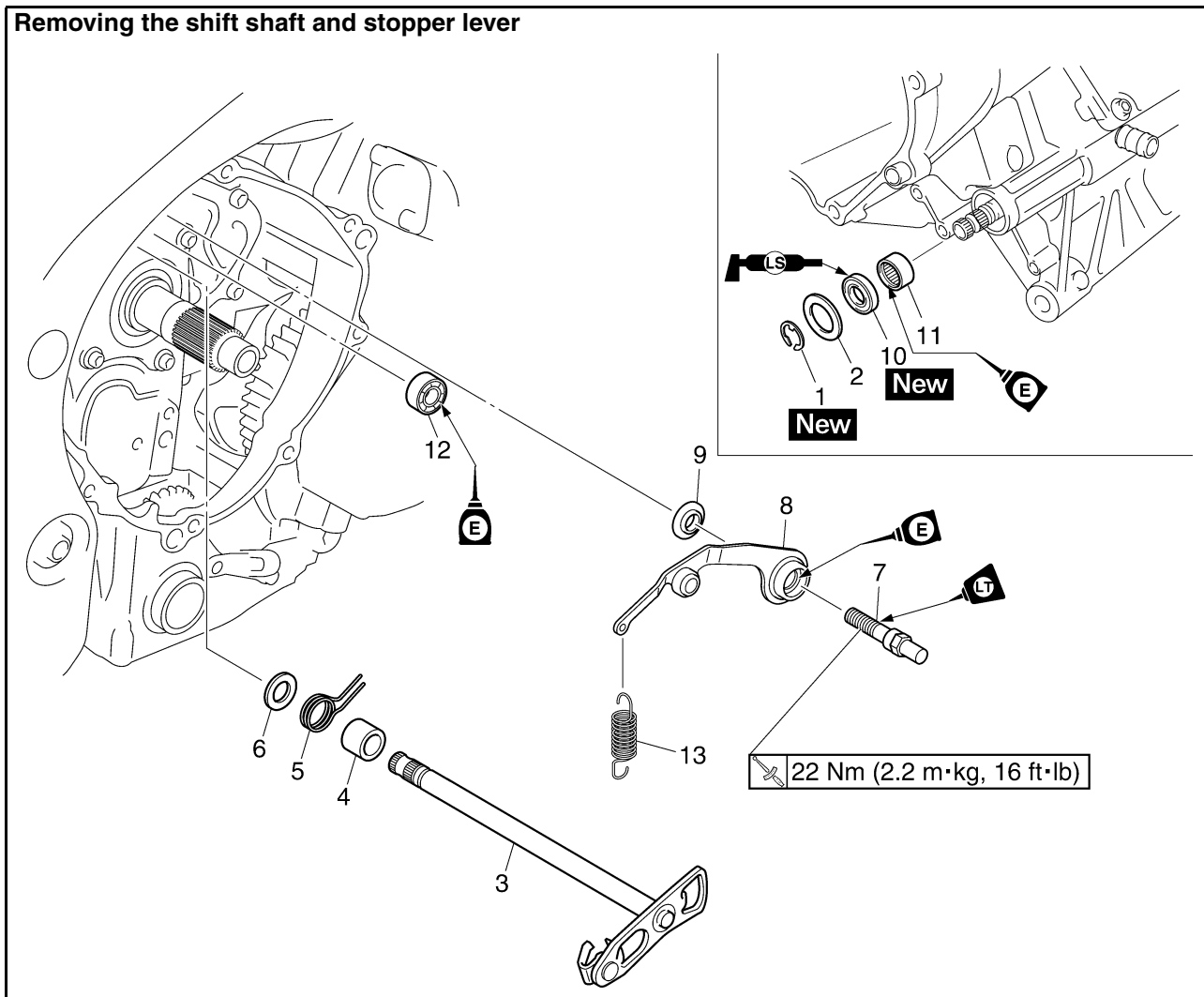

Order	Job/Parts to remove	Q'ty	Remarks
	Shift arm		Refer to "ENGINE REMOVAL" on page 5-1
	Clutch assembly		Refer to "CLUTCH" on page 5-44.
1	Circlip	1	
2	Washer	1	
3	Shift shaft	1	
4	Collar	1	
5	Shift shaft spring	1	
6	Washer	1	
7	Stopper screw	1	
8	Stopper lever	1	
9	Washer	1	
10	Oil seal	1	
11	Bearing	1	
12	Bearing	1	
13	Stopper lever spring	1	
			For installation, reverse the removal procedure.

# SHIFT SHAFT

EAS4C81008

## REMOVING THE SHIFT SHAFT

1. Remove:
  - Clutch assembly  
Refer to "CLUTCH" on page 5-44
2. Remove:
  - Shift arm
  - Shift rod  
Refer to "ENGINE REMOVAL" on page 5-1
3. Remove:
  - Circlip "1"
  - Washer "2"  
(left side of the engine)

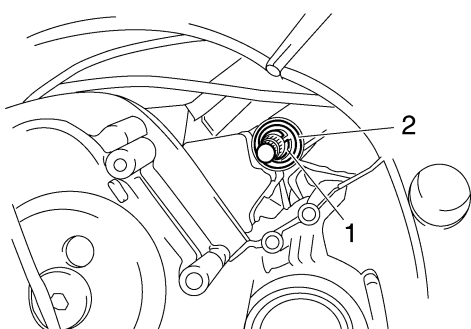
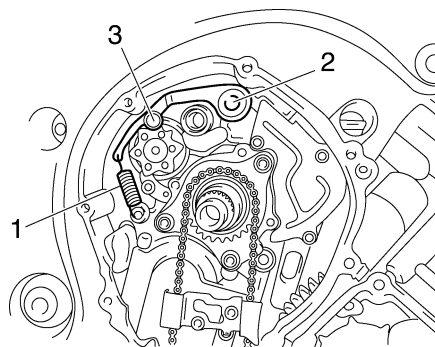

4. Remove
  - Shift shaft "1"
  - Shift shaft spring "2"
  - Collar
  - Washer

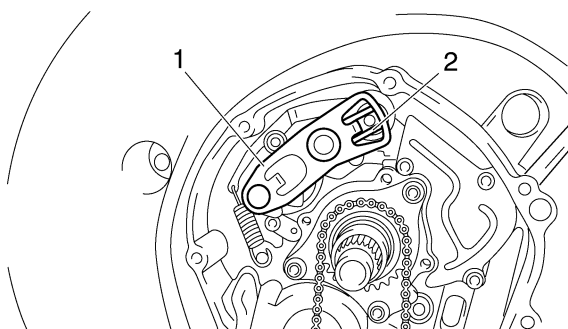

5. Remove:
  - Stopper lever spring "1"
  - Stopper screw "2"
  - Stopper lever "3"
  - Washer

EAS25420

## CHECKING THE SHIFT SHAFT

1. Check:
  - Shift shaft "1"  
Bends/damage/wear → Replace.
  - Shift lever spring "2"
  - Collar "3"  
Damage/wear → Replace.

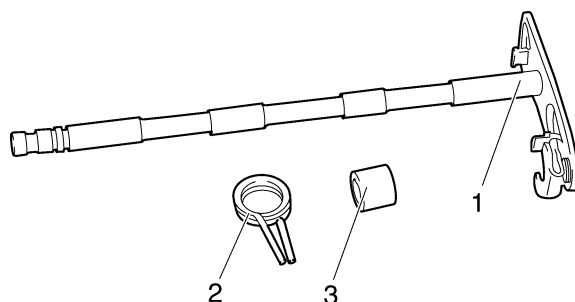

EAS25430

## CHECKING THE STOPPER LEVER

1. Check:
  - Stopper lever "1"  
Bends/damage → Replace.  
Roller turns roughly → Replace the stopper lever.

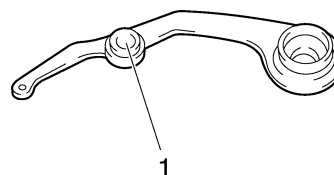

EAS25450

## INSTALLING THE SHIFT SHAFT

1. Install:
  - Washer
  - Stopper lever "1"
  - Stopper screw "2"



**Stopper screw**  
22 Nm (2.2 m·kg, 16 ft·lb)  
LOCTITE®

## SHIFT SHAFT

- Stopper lever spring "3"

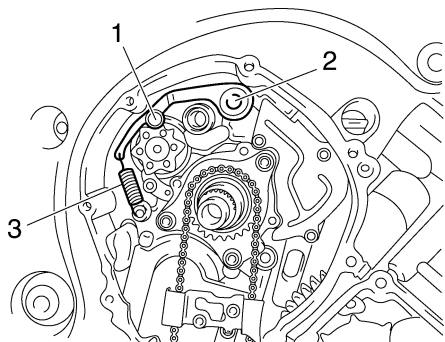

- Shift rod
- Shift arm  
Refer to "ENGINE REMOVAL" on page 5-1.

5. Install:
- Clutch assembly  
Refer to "CLUTCH" on page 5-44.

2. Install:
- Washer
  - Collar
  - Shift shaft spring "1"
  - Shift shaft "2"

**NOTE:**

- Mesh the stopper lever with the shift drum segment assembly.
- Lubricate the oil seal lips with lithium soap base grease.
- Install the end of the shift shaft spring onto the shift shaft spring stopper.

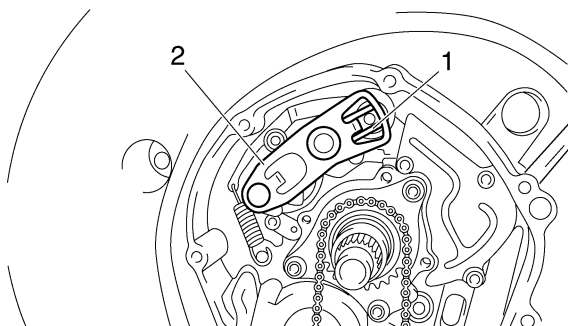

3. Install:
- Washer "1"
  - Circlip "2" **New**

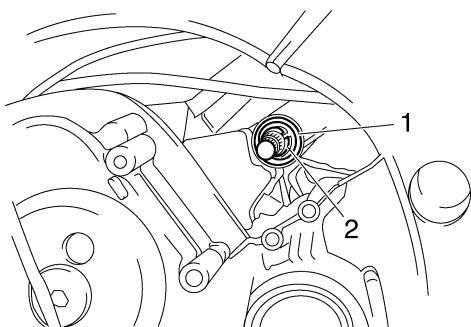

4. Install:

# OIL PUMP

EAS24920

## OIL PUMP

### Removing the oil pan and oil pump

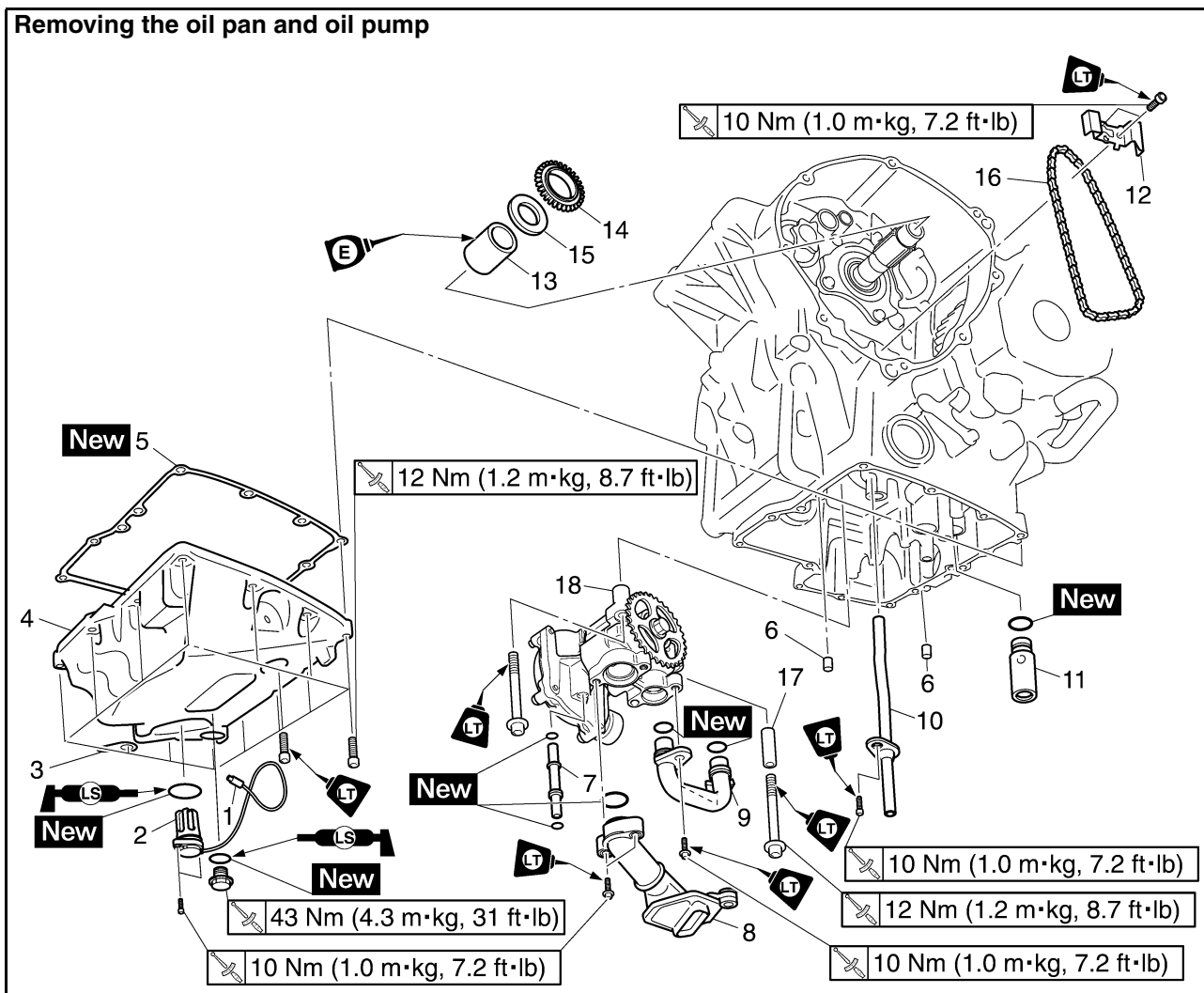

Order	Job/Parts to remove	Q'ty	Remarks
	Side cowlings		Refer to "GENERAL CHASSIS" on page 4-1.
	Lower cowlings		Refer to "GENERAL CHASSIS" on page 4-1.
	Engine oil		Drain. Refer to "CHANGING THE ENGINE OIL" on page 3-12.
	EXUP cables		Refer to "ENGINE REMOVAL" on page 5-1
	O <sub>2</sub> sensor		Refer to "ENGINE REMOVAL" on page 5-1
	Muffler		Refer to "ENGINE REMOVAL" on page 5-1
	Exhaust pipe assembly		Refer to "ENGINE REMOVAL" on page 5-1
	Clutch assembly		Refer to "CLUTCH" on page 5-44.
	Water pump inlet pipe		Refer to "OIL COOLER" on page 6-4.
	Water pump outlet pipe		Refer to "OIL COOLER" on page 6-4.
1	Oil level switch lead coupler	1	Disconnect.
2	Oil level switch	1	
3	Oil level switch lead holder	1	
4	Oil pan	1	
5	Oil pan gasket	1	
6	Dowel pin	1	
7	Drain pipe	2	

# OIL PUMP

## Removing the oil pan and oil pump

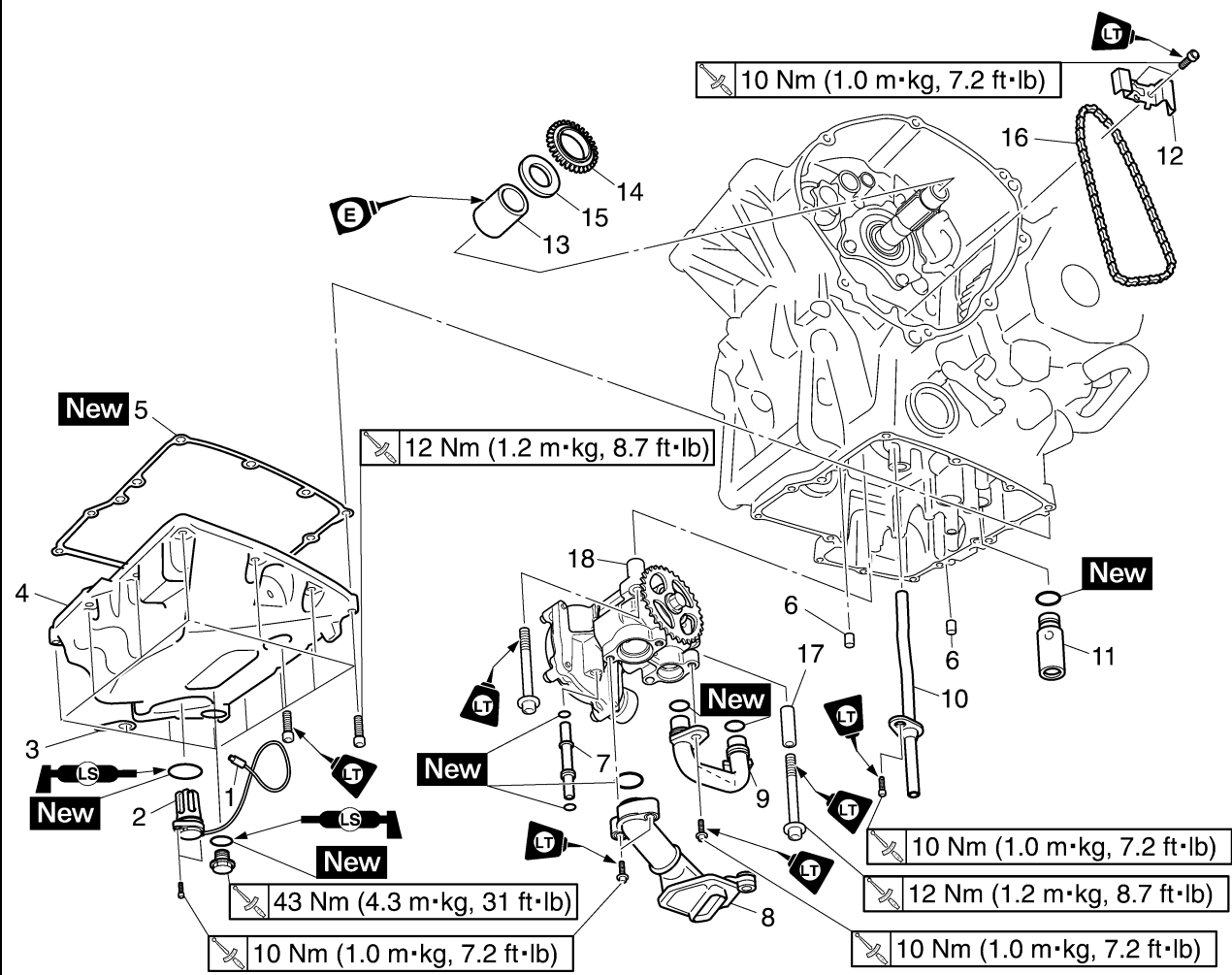

Order	Job/Parts to remove	Q'ty	Remarks
8	Oil strainer	1	
9	Oil pipe	1	
10	Oil delivery pipe	1	
11	Relief valve assembly	1	
12	Oil/water pump assembly drive chain guide	1	
13	Collar	1	
14	Oil/water pump assembly drive sprocket	1	
15	Washer	1	
16	Oil/water pump assembly drive chain	1	
17	Dowel pin	1	
18	Oil/water pump assembly	1	
			For installation, reverse the removal procedure.

# OIL PUMP

## Disassembling the oil pump

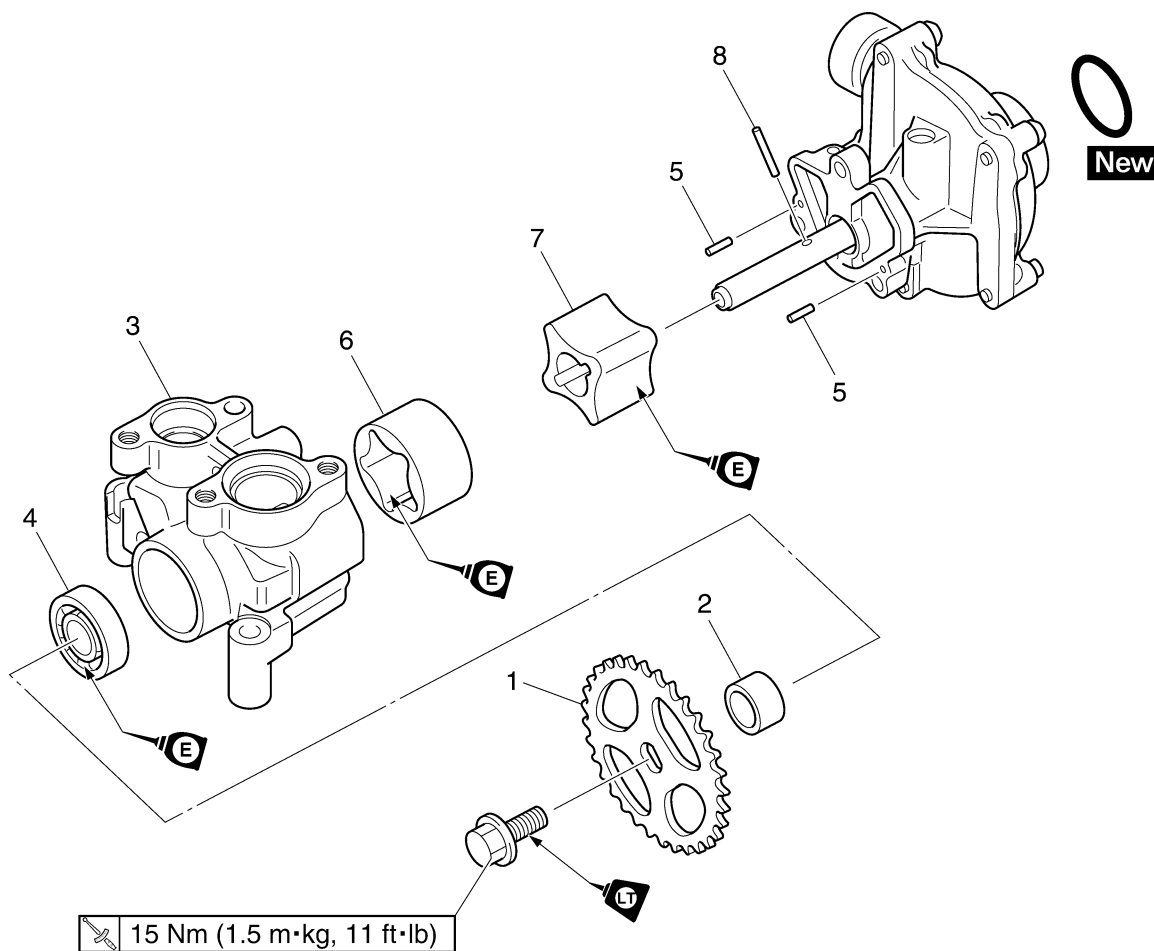

Order	Job/Parts to remove	Q'ty	Remarks
1	Oil/water pump driven sprocket	1	
2	Collar	1	
3	Oil pump housing	1	
4	Bearing	1	
5	Pin	2	
6	Oil pump outer rotor	1	
7	Oil pump inner rotor	1	
8	Pin	1	
			For assembly, reverse the disassembly procedure.

# OIL PUMP

EAS24930

## REMOVING THE OIL PAN

- Remove:
  - Oil level switch "1"
  - Oil pan "2"
  - Gasket
  - Dowel pins

### NOTE:

Loosen each bolt 1/4 of a turn at a time, in stages and in a crisscross pattern. After all of the bolts are fully loosened, remove them.

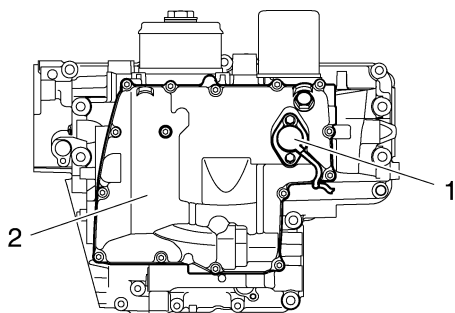

EAS4C81012

## CHECKING THE SPROCKET AND CHAIN

- Check:
  - Oil/water pump assembly drive sprocket "1"  
Cracks/damage/wear → Replace the defective part(-s).

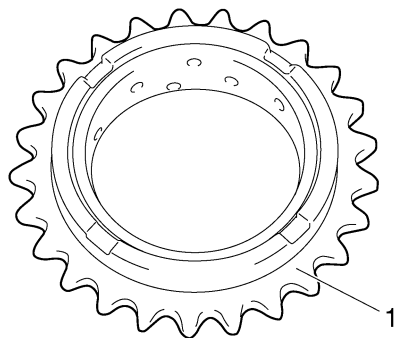

- Check:
  - Oil/water pump assembly drive chain "1"  
Damage/stiffness → Replace the oil/water pump assembly drive chain and oil/water pump assembly drive sprocket as a set.

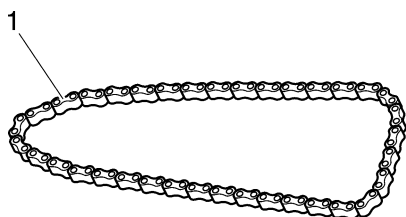

EAS24960

## CHECKING THE OIL PUMP

- Check:
  - Oil pump driven gear "1"
  - Oil pump housing "2"  
Cracks/damage/wear → Replace the defective part(-s).

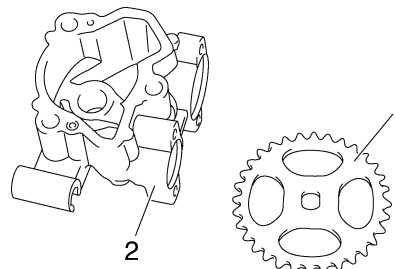

- Measure:
  - Inner-rotor-to-outer-rotor-tip clearance "a"
  - Outer-rotor-to-oil-pump-housing clearance "b"
  - Oil-pump-housing-to-inner-rotor-and-outer-rotor clearance "c"  
Out of specification → Replace the oil pump.



### Inner-rotor-to-outer-rotor-tip clearance

0.010–0.100 mm (0.0004–0.0039 in)

### Limit

0.180 mm (0.0071 in)

### Outer-rotor-to-oil-pump-housing clearance

0.090–0.190 mm (0.0035–0.0074 in)

### Limit

0.220 mm (0.0087 in)

### Oil-pump-housing-to-inner-and-outer-rotor clearance

0.06–0.13 mm (0.0024–0.0051 in)

### Limit

0.200 mm (0.0079 in)

# OIL PUMP

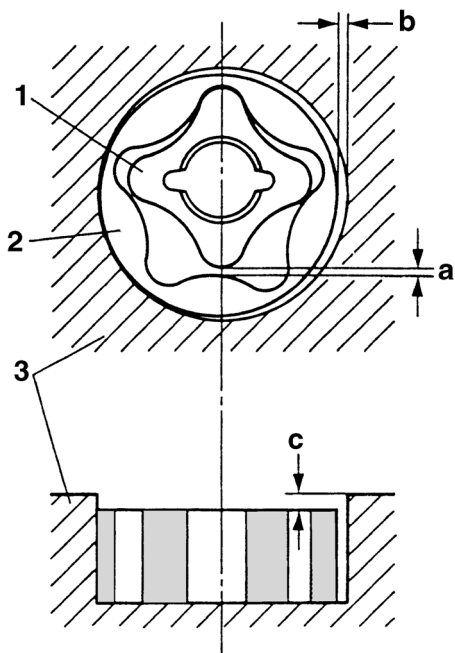

- 1. Inner rotor
- 2. Outer rotor
- 3. Oil pump housing
- 3. Check:
  - Oil pump operation
 Rough movement → Repeat steps (1) and (2) or replace the defective part(s).

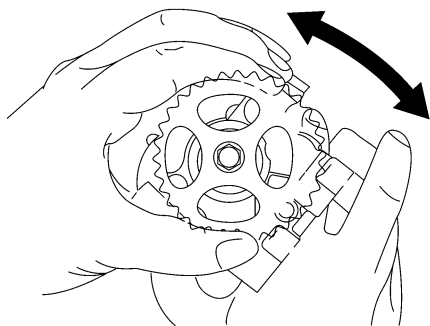

EAS24970  
**CHECKING THE RELIEF VALVE**

- 1. Check:
  - Relief valve body "1"
  - Relief valve "2"
  - Spring "3"
  - O-ring "4"
 Damage/wear → Replace the defective part(s).

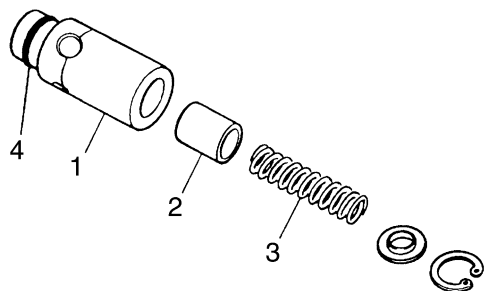

EAS24980  
**CHECKING THE OIL DELIVERY PIPES**

The following procedure applies to all of the oil delivery pipes.

- 1. Check:
  - Oil delivery pipe "1"
  - Oil pipe "2"
 Damage → Replace.  
 Obstruction → Wash and blow out with compressed air.

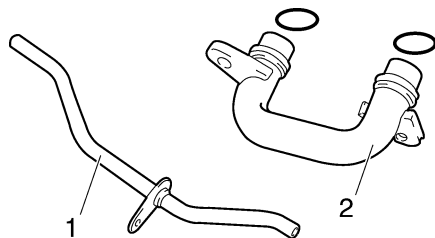

EAS24990  
**CHECKING THE OIL STRAINER**

- 1. Check:
  - Oil strainer "1"
 Damage → Replace.  
 Contaminants → Clean with solvent.

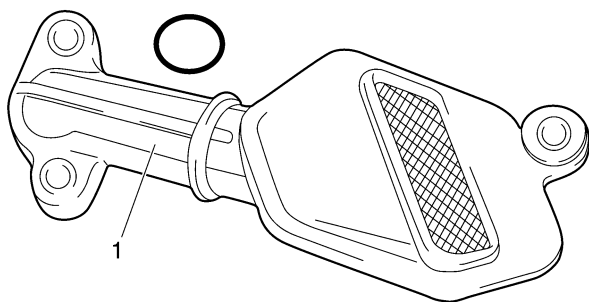

EAS4C81013  
**CHECKING THE OIL NOZZLES**

The following procedure applies to all of the oil nozzles.

- 1. Check:
  - Oil nozzle "1"
 Damage/wear → Replace the oil nozzles.

## OIL PUMP

- O-ring "2"  
Damage/wear → Replace.
- Oil nozzle passage  
Obstruction → Blow out with compressed air.

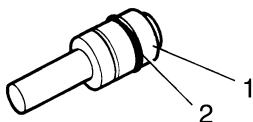

**Oil/water pump driven sprocket bolt**  
**15 Nm (1.5 m·kg, 11 ft·lb)**  
**LOCTITE®**

**NOTE:** \_\_\_\_\_

5VY mark of the oil/water pump driven gear is installed at oil pump side.

EAS25010

### ASSEMBLING THE OIL PUMP

1. Lubricate:
  - Inner rotor
  - Outer rotor
  - Oil pump shaft  
(with the recommended lubricant)

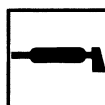

**Recommended lubricant**  
**Engine oil**

2. Install:
  - Pin "1"
  - Inner rotor "2"
  - Outer rotor "3"
  - Oil pump housing "4"

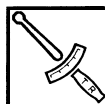

**Oil pump housing bolt**  
**10 Nm (1.0 m·kg, 7.2 ft·lb)**  
**LOCTITE®**

**NOTE:** \_\_\_\_\_

When installing the inner rotor, align the pin "1" in the oil pump shaft with the groove "a" in the inner rotor "2".

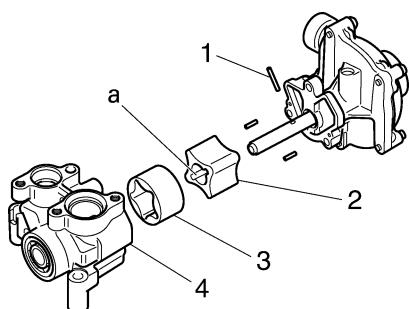

3. Install:
  - Oil/water pump driven sprocket "1"

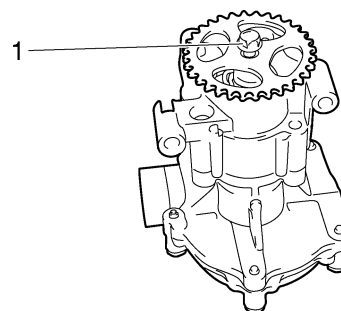

4. Check:
  - Oil pump operation  
Refer to "CHECKING THE OIL PUMP" on page 5-60.

EAS25030

### INSTALLING THE OIL/WATER PUMP ASSEMBLY

1. Install:
  - Oil ring **New**
  - Oil/water pump assembly "1"
  - Dowel pin
  - Bolts "2"

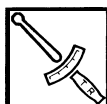

**Oil/water pump assembly bolt**  
**12 Nm (1.2 m·kg, 8.7 ft·lb)**  
**LOCTITE®**

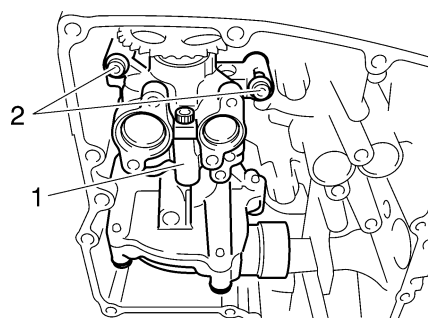

2. Install:
  - Washer
  - Oil/water pump assembly drive chain "1"
  - Oil/water pump assembly drive sprocket "2"
  - Collar

## OIL PUMP

**NOTE:**

Install the oil/water pump assembly drive chain "1" onto the oil/water pump assembly drive sprocket "2".

ECA4C81007

**CAUTION:**

After installing the oil/water pump assembly drive chain and drive sprocket, make sure the oil/water pump turns smoothly.

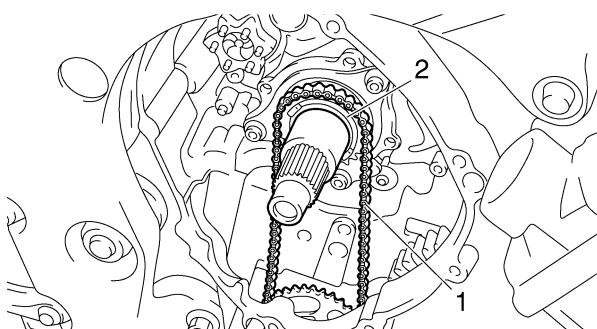

3. Install:

- Oil/water pump assembly drive chain guide "1"



**Oil/water pump assembly drive chain guide bolt**  
 10 Nm (1.0 m·kg, 7.2 ft·lb)  
 LOCTITE®

**NOTE:**

"UP" mark of the oil/water pump assembly drive chain guide is upward.

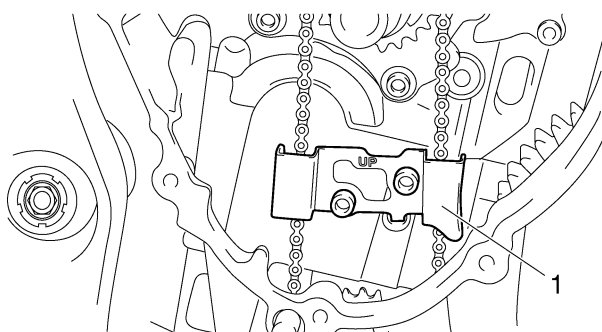

4. Install:

- Oil delivery pipe "1"

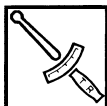

**Oil delivery pipe bolt**  
 10 Nm (1.0 m·kg, 7.2 ft·lb)  
 LOCTITE®

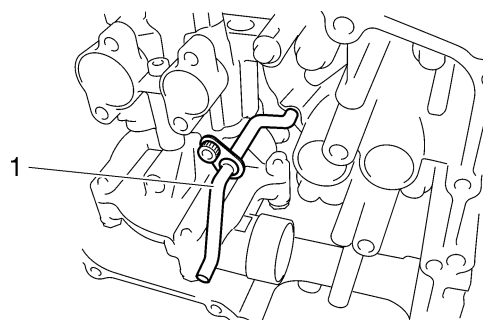

5. Install:

- Relief valve "1"
- O-ring **New**
- Oil strainer "2"

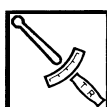

**Oil strainer bolt**  
 10 Nm (1.0 m·kg, 7.2 ft·lb)  
 LOCTITE®

- O-ring **New**
- Oil pipe "3"
- O-ring **New**
- Drain pipe "4"
- O-ring **New**

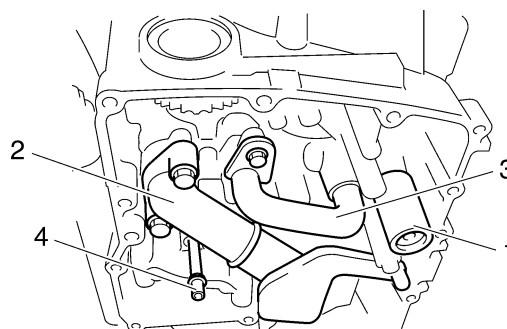

EAS25050

**INSTALLING THE OIL PAN**

1. Install:

- Dowel pins
- Gasket **New**
- Oil pan "1"



**Oil pan bolt**  
 12 Nm (1.2 m·kg, 8.7 ft·lb)

- Oil level switch "2"

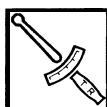

**Oil level switch bolt**  
 10 Nm (1.0 m·kg, 7.2 ft·lb)

- Engine oil drain bolt

## OIL PUMP



**Engine oil drain bolt**  
**43 Nm (4.3 m·kg, 31 ft·lb)**

EWA12820



**Always use new copper washers.**

**NOTE:**

- Tighten the oil pan bolts in stages and in a crisscross pattern.
- Lubricate the oil level switch O-ring with engine oil.

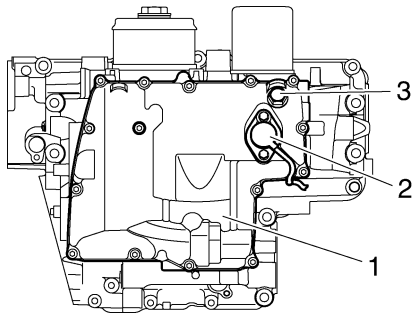

# CRANKCASE

EAS25540

## CRANKCASE

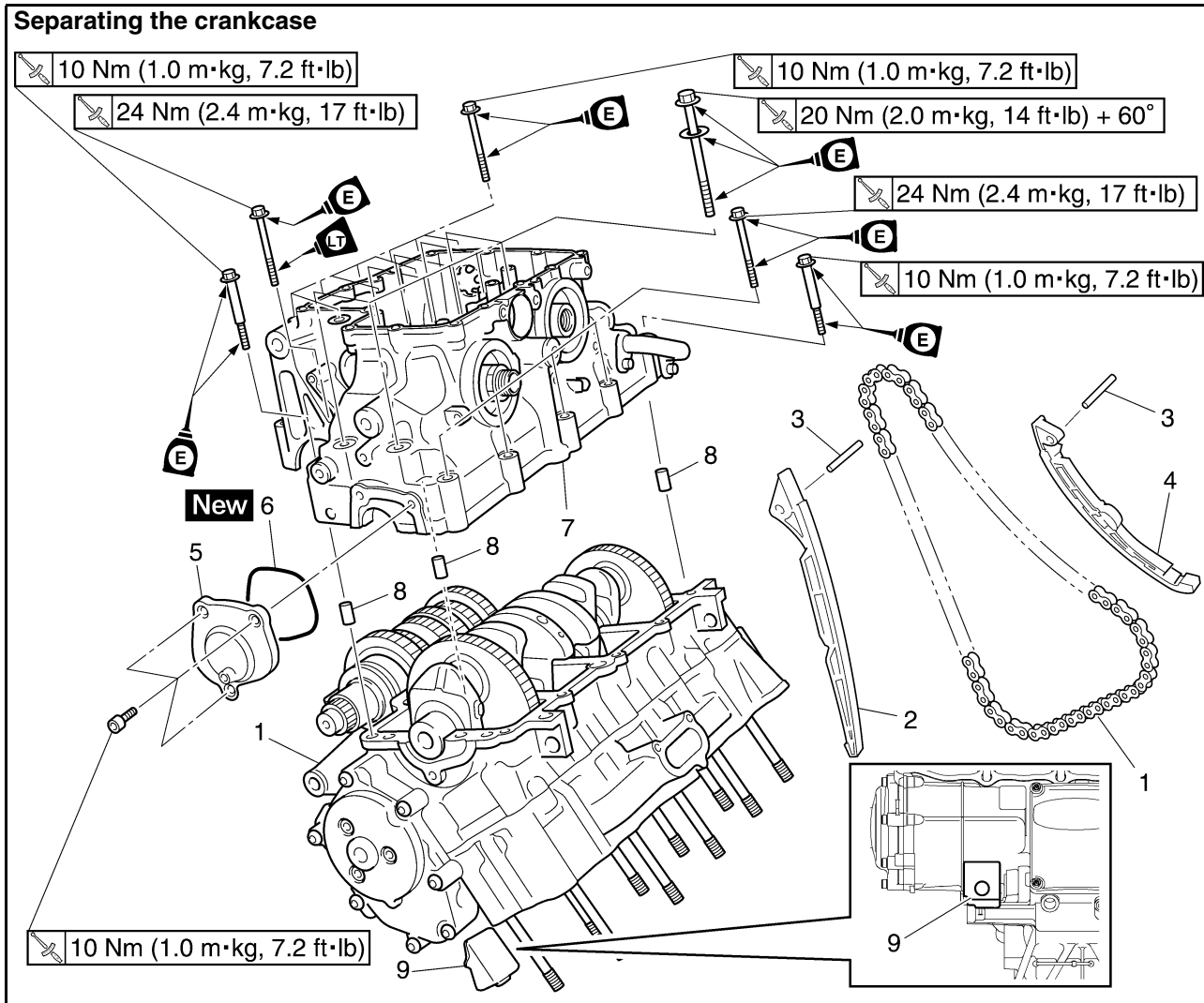

Order	Job/Parts to remove	Q'ty	Remarks
	Air filter case		Refer to "GENERAL CHASSIS" on page 4-1.
	Throttle body assembly		Refer to "THROTTLE BODIES" on page 7-4.
	Engine		Refer to "ENGINE REMOVAL" on page 5-1
	Cylinder head		Refer to "CYLINDER HEAD" on page 5-18.
	Generator		Refer to "GENERATOR" on page 5-30.
	Starter clutch		Refer to "STARTER CLUTCH" on page 5-34.
	Shift shaft		Refer to "SHIFT SHAFT" on page 5-54.
	Crankshaft position sensor		Refer to "CRANKSHAFT POSITION SENSOR" on page 5-37.
	Clutch		Refer to "CLUTCH" on page 5-44.
	Oil pump		Refer to "OIL PUMP" on page 5-57.
	Starter motor		Refer to "ELECTRIC STARTER" on page 5-39.
1	Timing chain	1	
2	Timing chain guide (intake side)	1	
3	Pin	2	
4	Timing chain guide (exhaust side)	1	
5	Left side cover	1	
6	O-ring	1	

# CRANKCASE

## Separating the crankcase

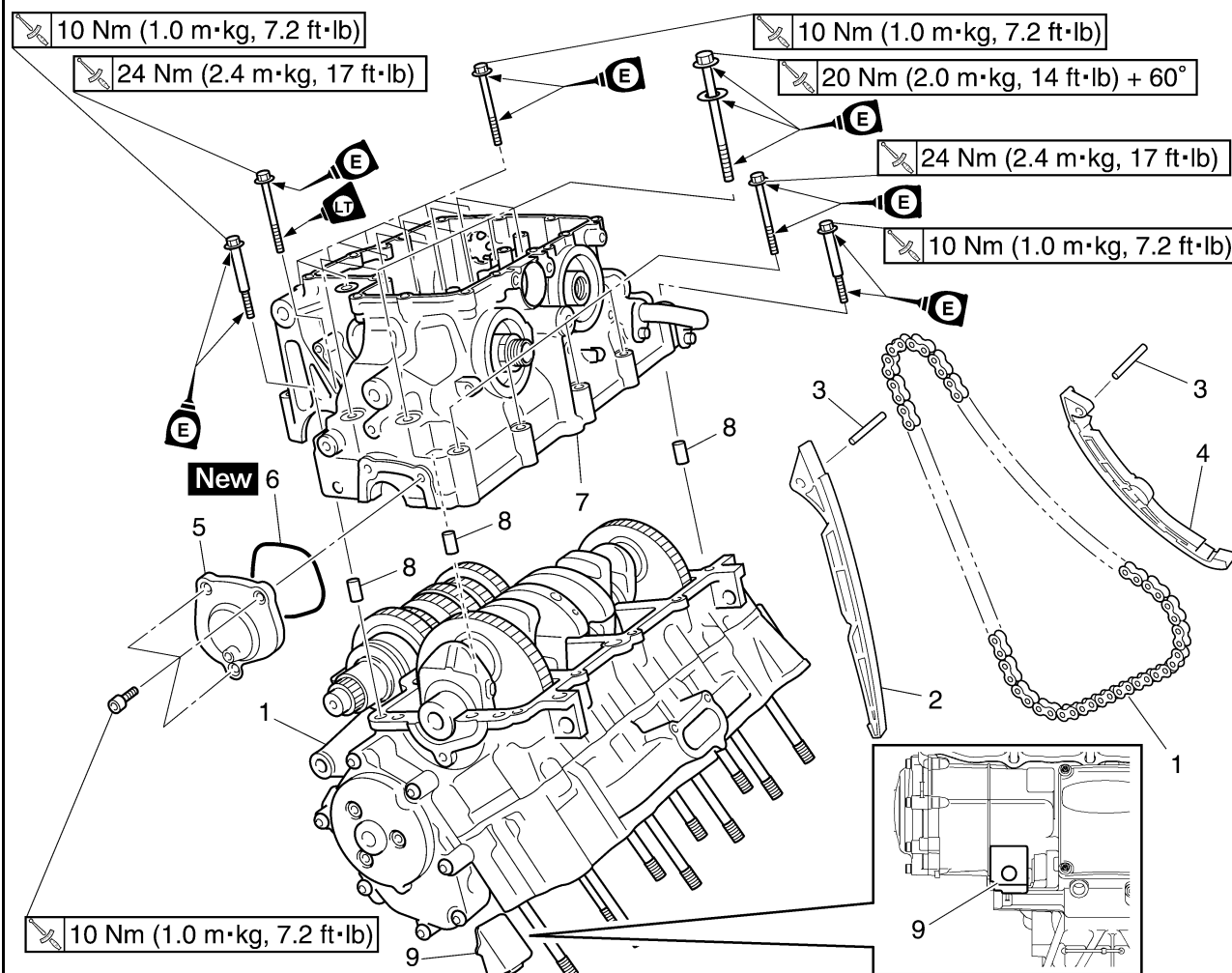

Order	Job/Parts to remove	Q'ty	Remarks
7	Lower crankcase	1	
8	Dowel pin	3	
9	Damper	1	
			For installation, reverse the removal procedure.

# CRANKCASE

EAS25550

## DISASSEMBLING THE CRANKCASE

1. Place the engine upside down.
2. Remove:
  - Crankcase bolts

### NOTE:

- Loosen each bolt 1/4 of a turn at a time, in stages and in a crisscross pattern. After all of the bolts are fully loosened, remove them.
- Loosen the bolts in decreasing numerical order (refer to the numbers in the illustration).
- The numbers embossed on the crankcase indicate the crankcase tightening sequence.

- M6 x 50 mm (2.0 in) bolts: "1", "7"
- M6 x 60 mm (2.4 in) bolts: "2", "3"
- M6 x 70 mm (2.8 in) bolts: "4", "6", "8"
- M6 x 60 mm (2.4 in) bolt and washer: "5"
- M6 x 65 mm (2.5 in) bolts: "9", "10"
- M8 x 60 mm (2.4 in) bolts: "11", "15"
- M8 x 50 mm (2.0 in) bolts: "12" – "14"
- M8 x 60 mm (2.4 in) bolt: "16" LOCTITE®
- M9 x 105 mm (4.1 in) bolts: "17" – "26"

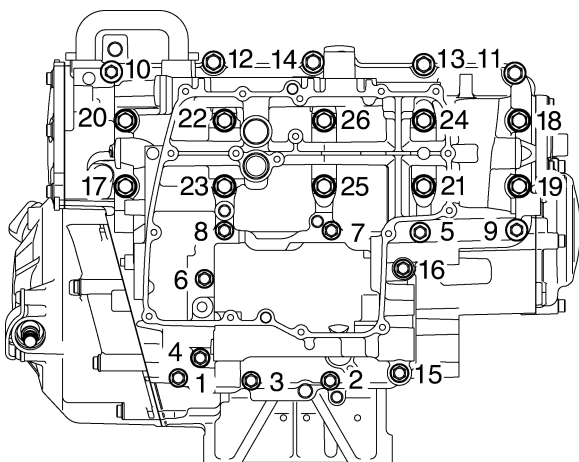

3. Remove:
  - Lower crankcase

ECA13900

### CAUTION:

**Tap on one side of the crankcase with a soft-face hammer. Tap only on reinforced portions of the crankcase, not on the crankcase mating surfaces. Work slowly and carefully and make sure the crankcase halves separate evenly.**

4. Remove:
  - Dowel pins
5. Remove:
  - Crankshaft journal lower bearing (from the lower crankcase)

### NOTE:

Identify the position of each crankshaft journal lower bearing so that it can be reinstalled in its original place.

EAS25580

## CHECKING THE CRANKCASE

1. Thoroughly wash the crankcase halves in a mild solvent.
2. Thoroughly clean all the gasket surfaces and crankcase mating surfaces.
3. Check:
  - Crankcase  
Cracks/damage → Replace.
  - Oil delivery passages  
Obstruction → Blow out with compressed air.

EAS4C81014

## CHECKING THE BEARING AND OIL SEALS

1. Check:
  - Bearings  
Clean and lubricate the bearings, then rotate the inner race with your finger.  
Rough movement → Replace.
2. Check:
  - Oil seals  
Damage/wear → Replace.

EAS25650

## ASSEMBLING THE CRANKCASE

1. Lubricate:
  - Crankshaft journal bearings (with the recommended lubricant)

	<b>Recommended lubricant Engine oil</b>
---	---

2. Apply:
  - Sealant

	<b>Yamaha bond No. 1215 (Three Bond No.1215®) 90890-85505</b>
---	---

### NOTE:

Do not allow any sealant to come into contact with the oil gallery or crankshaft journal bearings. Do not apply sealant to within 2–3 mm (0.08–0.12 in) of the crankshaft journal bearings.

## CRANKCASE

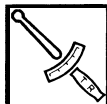
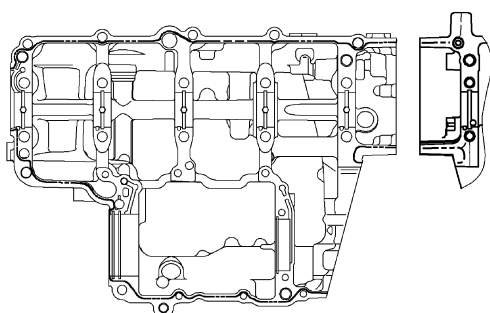

### Crankcase bolt

Bolt "1" – "10"

1st: 20 Nm (2.0 m·kg, 14 ft·lb)

2nd\*: 20 Nm (2.0 m·kg, 14 ft·lb)

3rd: +60°

Bolt "11" – "16"

24 Nm (2.4 m·kg, 17 ft·lb)

Bolt "17" – "26"

10 Nm (1.0 m·kg, 7.2 ft·lb)

\*Following the tightening order, loosen the bolt one by one and then retighten it to the specific torque.

3. Install:
  - Dowel pin
4. Set the shift drum assembly and transmission gears in the neutral position.
5. Install:
  - Lower crankcase "1"  
(onto the upper crankcase "2")

ECA13980

### CAUTION:

**Before tightening the crankcase bolts, make sure the transmission gears shift correctly when the shift drum assembly is turned by hand.**

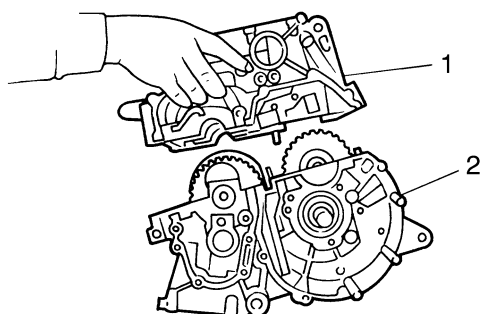
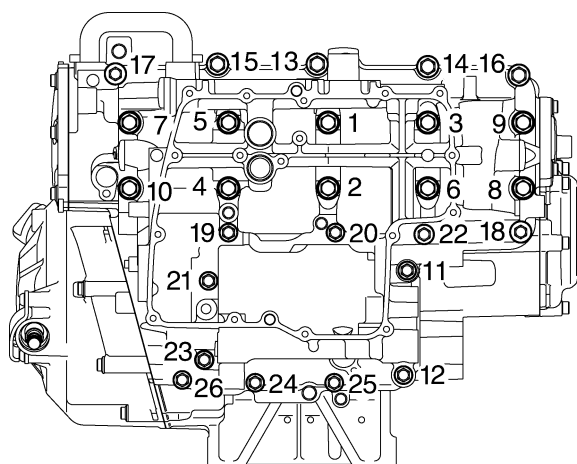

6. Install:
  - Crankcase bolts

### NOTE:

- Lubricate the bolt threads with engine oil.
- Install a washer on bolts "1" – "10" and "22".
- Seal bolt "18"
- Tighten the bolts in the tightening sequence cast on the crankcase.

M9 x 105 mm (4.1 in) bolts: "1" – "10"  
 M8 x 60 mm (2.4 in) bolt: "11" LOCTITE®  
 M8 x 60 mm (2.4 in) bolts: "12", "16"  
 M8 x 50 mm (2.0 in) bolts: "13" – "15"  
 M6 x 65 mm (2.5 in) bolts: "17", "18"  
 M6 x 70 mm (2.8 in) bolts: "19", "21", "23"  
 M6 x 50 mm (2.0 in) bolts: "20", "26"  
 M6 x 60 mm (2.4 in) bolt and washer: "22"  
 M6 x 60 mm (2.4 in) bolts: "24", "25"

# CRANKSHAFT

EAS25960

## CRANKSHAFT

### Removing the connecting rods and pistons

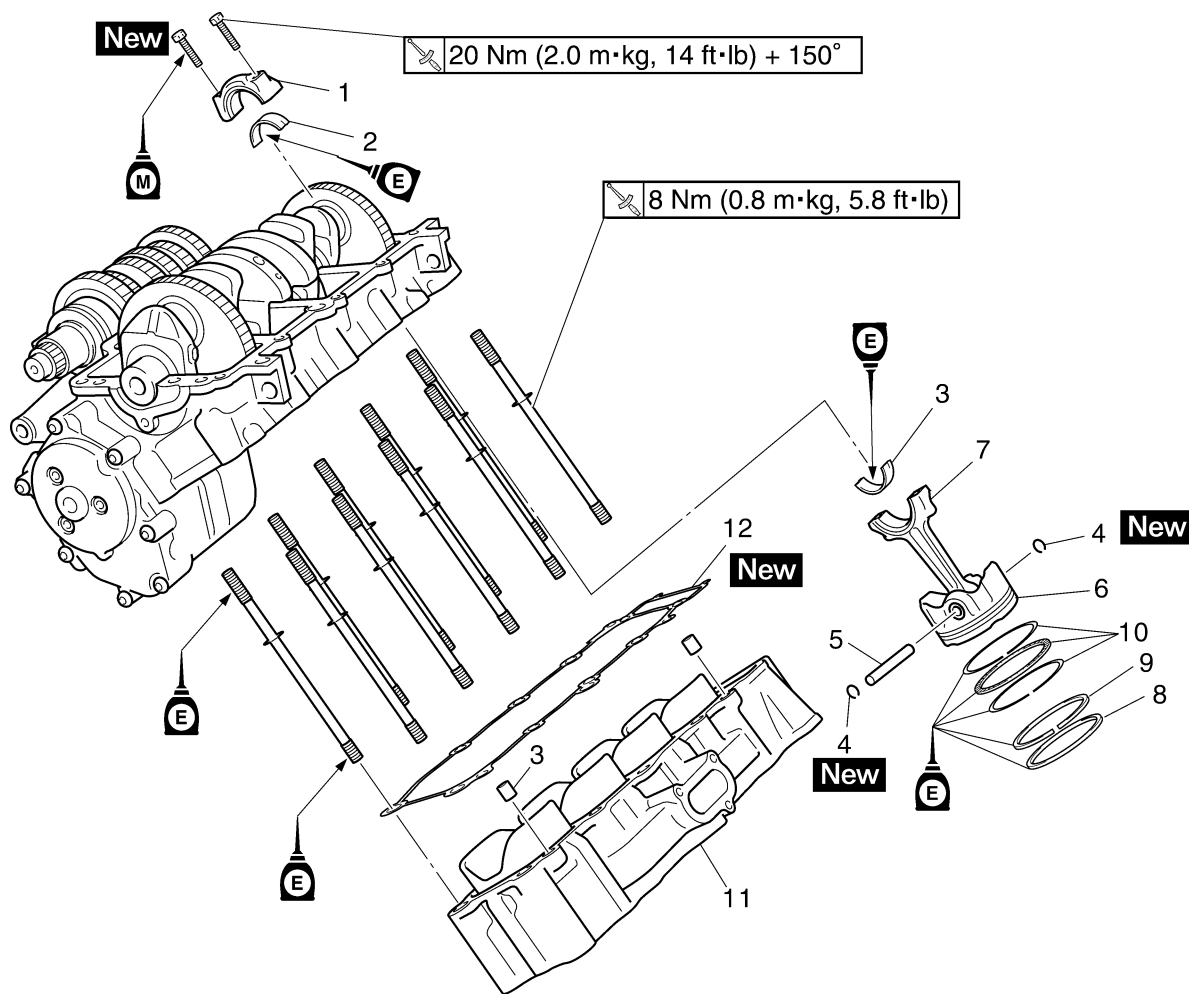

Order	Job/Parts to remove	Q'ty	Remarks
	Lower crankcase		Refer to "CRANKCASE" on page 5-65.
1	Connecting rod cap	4	
2	Big end lower bearing	4	
3	Big end upper bearing	4	
4	Piston pin clip	8	
5	Piston pin	4	
6	Piston	4	
7	Connecting rod	4	
8	Top ring	4	
9	2nd ring	4	
10	Oil ring	4	
11	Cylinder	1	
12	Cylinder gasket	1	
			For installation, reverse the removal procedure.

# CRANKSHAFT

## Removing the crankshaft

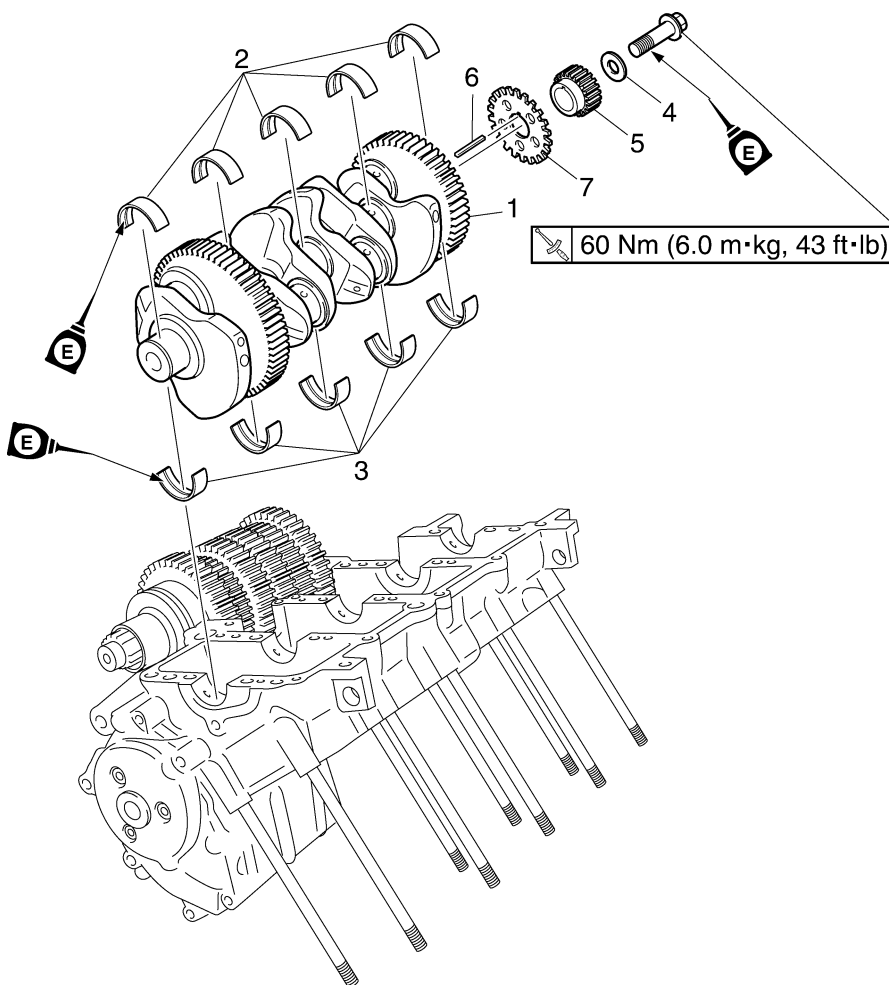

Order	Job/Parts to remove	Q'ty	Remarks
	Lower crankcase		Refer to "CRANKCASE" on page 5-65.
	Connecting rod and connecting rod caps		Refer to "REMOVING THE CONNECTING RODS AND PISTONS" on page 5-71.
1	Crankshaft	1	
2	Crankshaft journal lower bearing	5	
3	Crankshaft journal upper bearing	5	
4	Washer	1	
5	Crankshaft drive gear	1	
6	Pin	1	
7	Pickup rotor	1	
			For installation, reverse the removal procedure.

## CRANKSHAFT

EAS26030

### REMOVING THE CONNECTING RODS AND PISTONS

The following procedure applies to all of the connecting rods and pistons.

1. Remove:
  - Connecting rod cap "1"
  - Big end bearings

**NOTE:**

- Identify the position of each big end bearing so that it can be reinstalled in its original place.
- After removing the connecting rods and connecting rod caps, care should be taken not to damage the mating surfaces of the connecting rods and connecting rod caps.

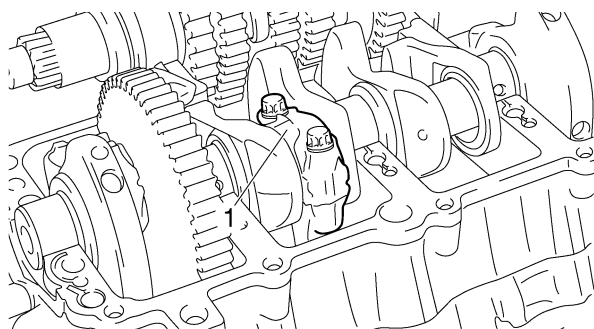

2. Remove:
  - Cylinder
  - Cylinder gasket
  - Cylinder stud bolts
3. Remove:
  - Piston pin clips "1"
  - Piston pin "2"
  - Piston "3"

ECA4C81008

**CAUTION:**

**Do not use a hammer to drive the piston pin out.**

**NOTE:**

- For reference during installation, put identification marks on the piston crown.
- Before removing the piston pin, deburr the piston pin clip groove and the piston pin bore area. If both areas are debarred and the piston pin is still difficult to remove, remove it with the piston pin puller set "4".



**Piston pin puller set**  
**90890-01304**  
**Piston pin puller**  
**YU-01304**

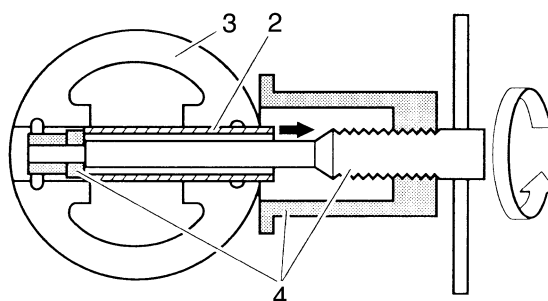
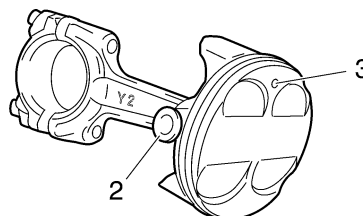

4. Remove:
  - Top ring
  - 2nd ring
  - Oil ring

**NOTE:**

When removing a piston ring, open the end gap with your fingers and lift the other side of the ring over the piston crown.

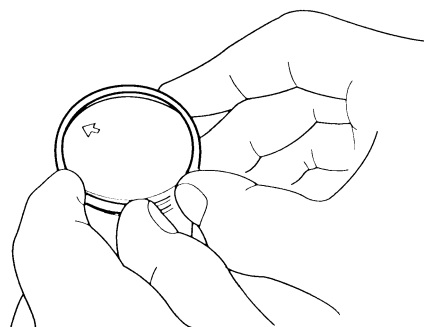

EAS25980

### REMOVING THE CRANKSHAFT ASSEMBLY

1. Remove:
  - Crankshaft assembly "1"
  - Crankshaft journal upper bearings (from the upper crankcase)
 Refer to "CRANKSHAFT" on page 5-69.

# CRANKSHAFT

**NOTE:**

Identify the position of each crankshaft journal upper bearing so that it can be reinstalled in its original place.

EAS24390

### CHECKING THE CYLINDER AND PISTON

1. Check:

- Piston wall
- Cylinder wall

Vertical scratches → Rebore or replace the cylinder, and replace the piston and piston rings as a set.

2. Measure:

- Piston-to-cylinder clearance



- a. Measure cylinder bore "C" with the cylinder bore gauge.

**NOTE:**

Measure cylinder bore "C" by taking side-to-side and front-to-back measurements of the cylinder. Then, find the average of the measurements.



**Bore**  
**77.000–77.010 mm (3.0315–3.0319 in)**  
**Wear limit**  
**77.060 mm (3.0339 in)**  
**Taper limit "T"**  
**0.050 mm (0.0020 in)**  
**Out of round limit "R"**  
**0.050 mm (0.0020 in)**

"C" = maximum of D<sub>1</sub>–D<sub>2</sub>  
 "T" = maximum of D<sub>1</sub> or D<sub>2</sub> - maximum of D<sub>5</sub> or D<sub>6</sub>  
 "R" = maximum of D<sub>1</sub>, D<sub>3</sub> or D<sub>5</sub> - minimum of D<sub>2</sub>, D<sub>4</sub> or D<sub>6</sub>

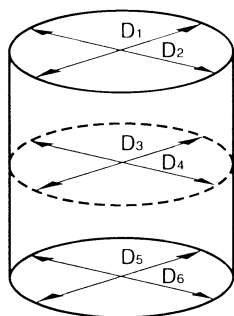

- b. If out of specification, rebore or replace the cylinder, and replace the piston and piston rings as a set.  
 c. Measure piston skirt diameter "P" with the micrometer.

	<b>Piston size "P"</b>
	<b>Standard</b>
	<b>76.975–76.990 mm (3.0305–3.0311 in)</b>

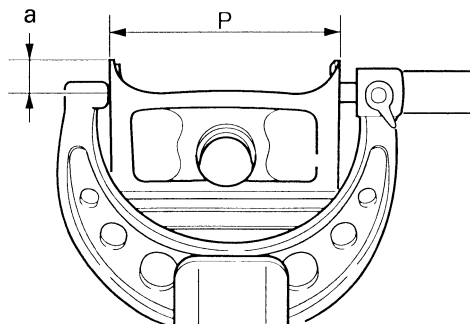

- a. 12 mm (0.47 in) from the bottom edge of the piston  
 d. If out of specification, replace the piston and piston rings as a set.  
 e. Calculate the piston-to-cylinder clearance with the following formula.

Piston-to-cylinder clearance =  
 Cylinder bore "C" -  
 Piston skirt diameter "P"



**Piston-to-cylinder clearance**  
**0.010–0.035 mm (0.0004–0.0014 in)**  
**Limit**  
**0.120 mm (0.0047 in)**

- f. If out of specification, rebore or replace the cylinder, and replace the piston and piston rings as a set.

EAS24430

### CHECKING THE PISTON RINGS

1. Measure:

- Piston ring side clearance  
 Out of specification → Replace the piston and piston rings as a set.

**NOTE:**

Before measuring the piston ring side clearance, eliminate any carbon deposits from the piston ring grooves and piston rings.

## CRANKSHAFT



### Piston ring side clearance

#### Top ring

0.030–0.065 mm (0.0012–0.0026 in)

#### Limit

0.115 mm (0.0045 in)

#### 2nd ring

0.020–0.055 mm (0.0008–0.0022 in)

#### Limit

0.115 mm (0.0045 in)

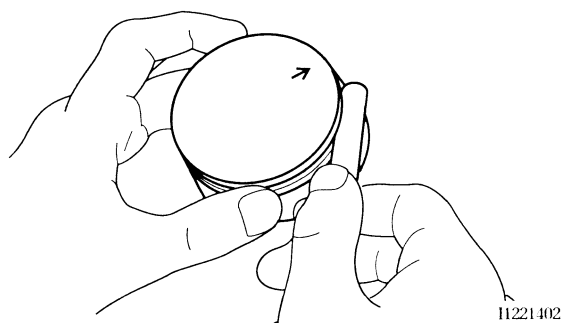

11221402

### 2. Install:

- Piston ring (into the cylinder)

### NOTE:

Level the piston ring into the cylinder with the piston crown.

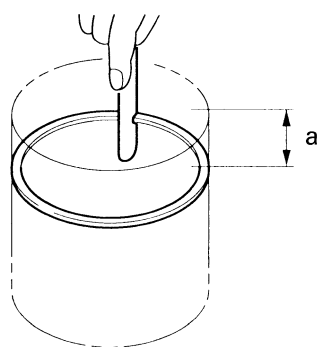

11221401

a. 5 mm (0.20 in)

### 3. Measure:

- Piston ring end gap  
Out of specification → Replace the piston ring.

### NOTE:

The oil ring expander spacer's end gap cannot be measured. If the oil ring rail's gap is excessive, replace all three piston rings.



### Piston ring end gap

#### Top ring

0.15–0.25 mm (0.0059–0.0098 in)

#### Limit

0.50 mm (0.0197 in)

#### 2nd ring

0.30–0.45 mm (0.0118–0.0177 in)

#### Limit

0.80 mm (0.0315 in)

#### Oil ring

0.10–0.40 mm (0.0039–0.0157 in)

EAS24440

### CHECKING THE PISTON PIN

#### 1. Check:

- Piston pin  
Blue discoloration/grooves → Replace the piston pin and then check the lubrication system.

#### 2. Measure:

- Piston pin outside diameter "a"  
Out of specification → Replace the piston pin.



### Piston pin outside diameter

16.991–17.000 mm (0.6689–0.6693 in)

#### Limit

16.971 mm (0.6682 in)

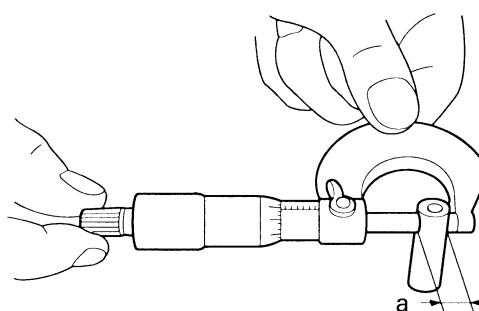

#### 3. Measure:

- Piston pin bore diameter "b"  
Out of specification → Replace the piston.



### Piston pin bore inside diameter

17.002–17.013 mm (0.6694–0.6698 in)

#### Limit

17.043 mm (0.6710 in)



# CRANKSHAFT

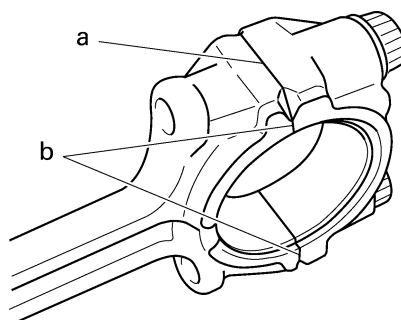
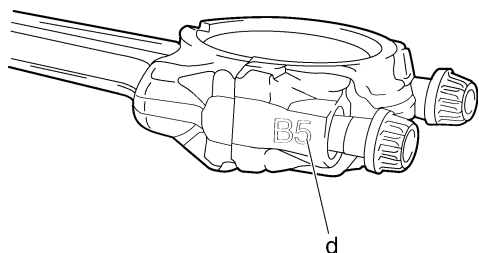
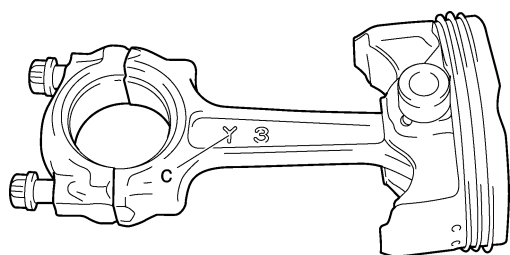

e. Tighten the connecting rod bolts.

**NOTE:**

Install by carrying out the following procedures in order to assemble in the most suitable condition.

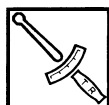

**Connecting rod bolt**  
29.4 Nm (3.0 m·kg, 21 ft·lb)

**NOTE:**

- First, tighten the bolts to 15 Nm (1.5 m·kg, 11 ft·lb).
- Retighten the bolts to 29.4 Nm (3.0 m·kg, 21 ft·lb).

- f. Replace the connecting rod bolts with new ones.
- g. Clean the connecting rod bolts.
- h. After installing big end bearing, assemble the connecting rod and connecting rod cap once using a single unit of the connecting rod.
- i. Tighten the connecting rod bolt while checking that the sections shown "a" and "b" are flush with each other by touching the surface.
- Side machined face "a"
  - Thrusting faces (4 places at front and rear) "b"

**NOTE:**

To install the big end bearing, care should be taken not to install it at an angle and the position should not be out of alignment.

- j. Loosen the connecting rod bolt, remove the connecting rod and connecting rod cap and install these parts to the crankshaft with the big end bearing kept in the current condition.
- k. Tighten the connecting rod bolts.



**Connecting rod bolt**  
20 Nm (2.0 m·kg, 14 ft·lb)  
+150°

EC2D1082

**CAUTION:**

**Tighten the connecting rod bolts using the plastic-region tightening angle method.**

- l. Clean the connecting rod bolts.
- m. Tighten the connecting rod bolts.
- n. Put a mark "1" on the corner of the connecting rod bolt "2" and the connecting rod "3".

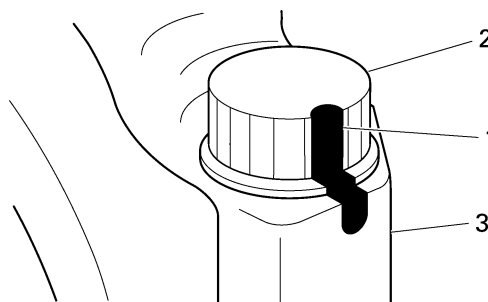

- o. Tighten the bolt further to reach the specified angle (150°).

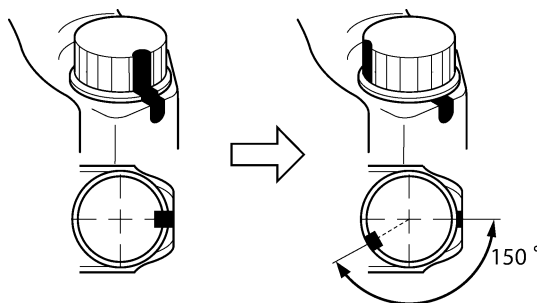

## CRANKSHAFT

p. After the installation, check that the section shown "a" is flush with each other by touching the surface.

- Side machined face "a"

EW2D1008

**⚠ WARNING**

- **When the bolt is tightened more than the specified angle, do not loosen the bolt and then retighten it.**

**Replace the bolt with a new one and perform the procedure again.**

- **If they are not flush with each other, remove the connecting rod bolt and big end bearing and restart from step "e". In this case, make sure to replace the connecting rod bolt.**

ECA4C81010

**CAUTION:**

- **Do not use a torque wrench to tighten the nut to the specified angle.**
- **Tighten the bolt until it is at the specified angles.**

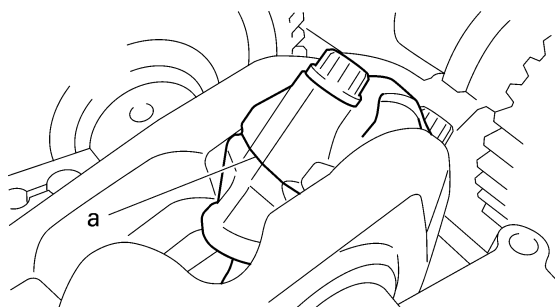

q. Remove the connecting rod and big end bearings.

Refer to "REMOVING THE CONNECTING RODS AND PISTONS" on page 5-71.

r. Measure the compressed Plastigauge® width on the crankshaft pin.

If the crankshaft-pin-to-big-end-bearing clearance is out of specification, select replacement big end bearings.

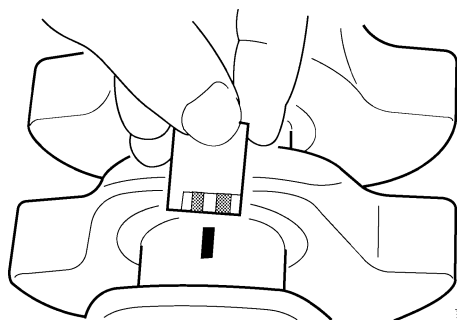

11630702



2. Select:

- Big end bearings (P1 – P4)

**NOTE:**

- The numbers "A" stamped into the crankshaft web and the numbers "1" on the connecting rods are used to determine the replacement big end bearings sizes.
- "P1" - "P4" refer to the bearings shown in the crankshaft illustration.

For example, if the connecting rod "P<sub>1</sub>" and the crankshaft web "P<sub>1</sub>" numbers are "5" and "2" respectively, then the bearing size for "P<sub>1</sub>" is:

<p>"P<sub>1</sub>" (connecting rod) – "P<sub>1</sub>" (crankshaft) = 5 – 2 = 3 (brown)</p>
--



**Bearing color code**

- |         |         |         |
|---------|---------|---------|
| 1.Blue  | 2.Black | 3.Brown |
| 4.Green |         |         |

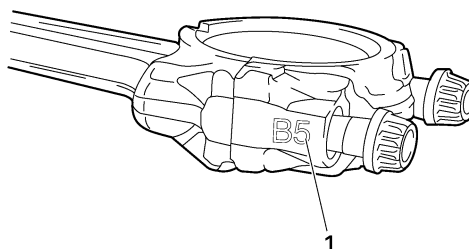
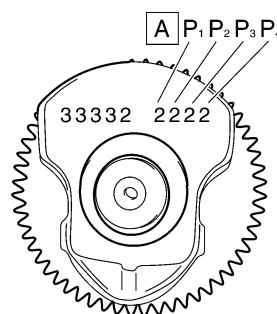
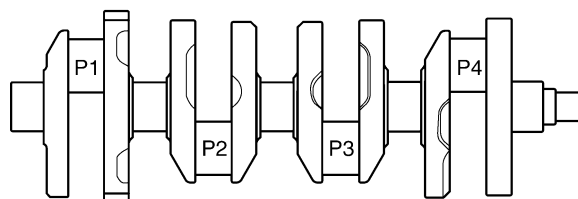

# CRANKSHAFT

EAS26190

## INSTALLING THE CONNECTING ROD AND PISTON

The following procedure applies to all of the connecting rods and pistons.

1. Install:
  - Top ring "1"
  - 2nd ring "2"
  - Oil ring expander "4"
  - Upper oil ring rail "3"
  - Lower oil ring rail "5"

**NOTE:**

Be sure to install the piston rings so that the manufacturer's marks or numbers "a" face up.

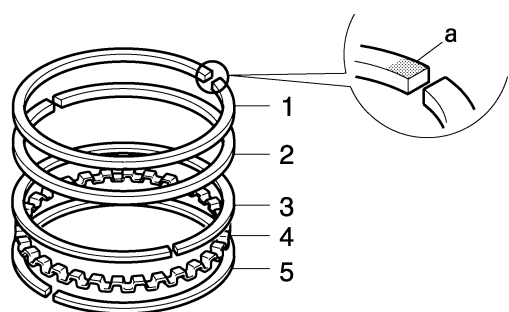

11221301

2. Install:
  - Piston "1"
  - (onto the respective connecting rod "2")
  - Piston pin "3"
  - Piston pin clip "4" **New**

**NOTE:**

- Apply engine oil onto the piston pin.
- Make sure that the "Y" mark "a" on the connecting rod faces left when the arrow mark "b" on the piston is pointing up as shown.
- Reinstall each piston into its original cylinder (numbering order starting from the left: #1 to #4).

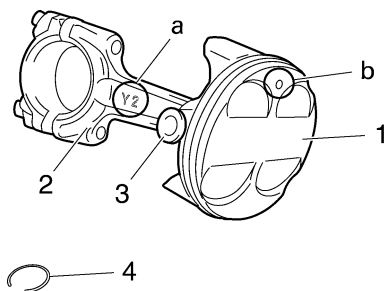

3. Lubricate:
  - Piston
  - Piston rings
  - Cylinder

(with the recommended lubricant)



4. Offset:
  - Piston ring end gaps

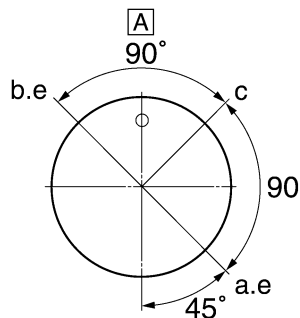

- a. Top ring
  - b. Lower oil ring rail
  - c. Upper oil ring rail
  - d. 2nd ring
  - e. Oil ring expander
  - A. Exhaust side
5. Lubricate:
    - Crankshaft pins
    - Big end bearings
    - Connecting rod big end inner surface (with the recommended lubricant)



6. Check:
  - Cylinder stud bolts "1"

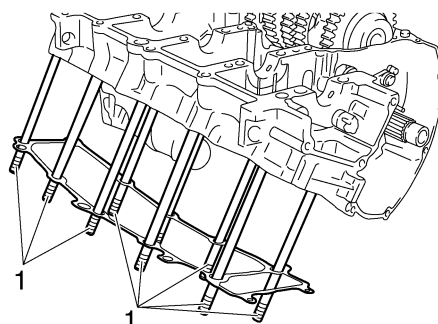
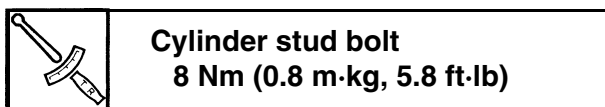

7. Install:
  - Cylinder gasket "2" **New**

# CRANKSHAFT

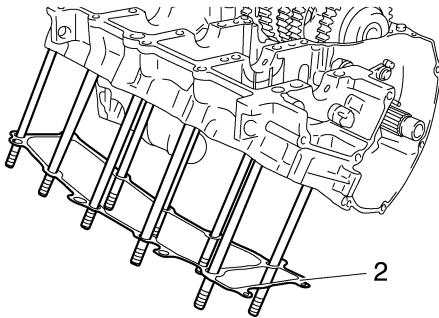

**8. Install:**

- Big end bearings  
(onto the connecting rods and connecting rod caps)

**NOTE:**

- Align the projections “a” on the big end bearings with the notches “b” in the connecting rods and connecting rod caps.
- Be sure to reinstall each big end bearing in its original place.
- Make sure that the characters “c” a on both the connecting rod and connecting rod cap are aligned.

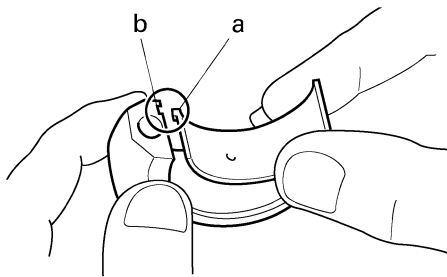

11630301

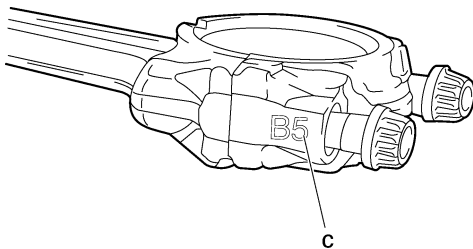

**9. Tighten:**

- Connecting rod bolts

	<p><b>Connecting rod bolt</b> <b>29.4 Nm (3.0 m·kg, 21 ft·lb)</b></p>
--	---

**NOTE:**

- Install by carrying out the following procedures in order to assemble in the most suitable condition.
- First tighten the bolts to 15 Nm (1.5 m·kg, 11 ft·lb)
- Retighten the bolts to 29.4 Nm (3.0 m·kg, 21 ft·lb)



- a. Replace the connecting rod bolts with new ones.
- b. Clean the connecting rod bolts.
- c. After installing the big end bearing, assemble the connecting rod and connecting rod cap once using a single unit of the connecting rod.
- d. Tighten the connecting rod bolt while checking that the sections shown “a” and “b” are flush with each other by touching the surface.

**NOTE:**

To install the big end bearing, care should be taken not to install it at an angle and the position should not be out of alignment.

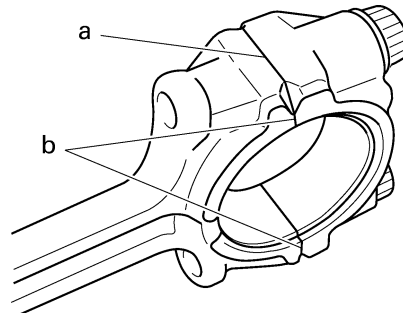

- a. Side machined face
- b. Thrusting faces (4 places at front and rear)
- e. Loosen the connecting rod bolt, remove the connecting rod and connecting rod cap and install these parts to the crankshaft with the big end bearing kept in the current condition.



**10. Install:**

- Piston assemblies “1”  
(into the cylinder)

**NOTE:**

While compressing the piston rings with one hand, install the connecting rod assembly into the cylinder with the other hand.

# CRANKSHAFT

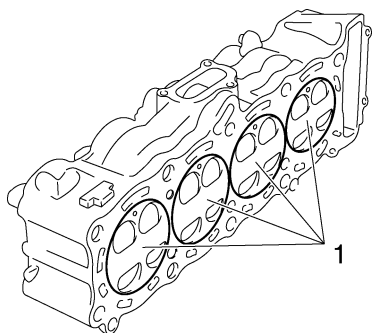

**11. Install:**

- Cylinder assembly "1"
- Connecting rod caps "2"

**NOTE:**

- Make sure that the "Y" marks "a" on the connecting rods face towards the left side of the crankshaft.
- Make sure that the characters on both the connecting rod and connecting rod cap are aligned.

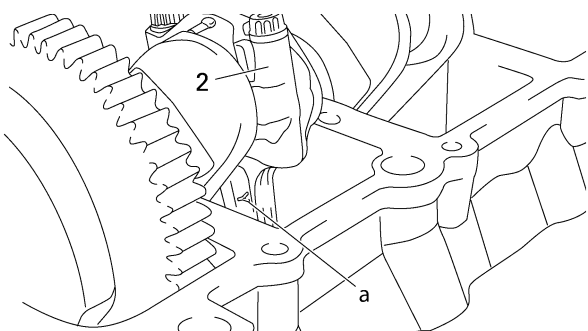
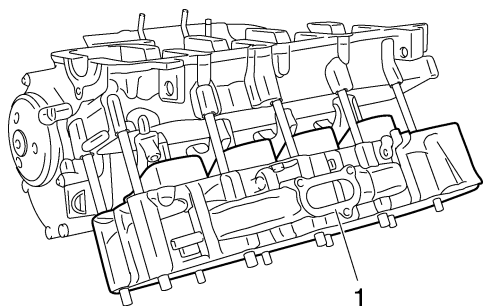

**12. Tighten:**

- Connecting rod bolts

	<p><b>Connecting rod bolt</b>  <b>20 Nm (2.0 m·kg, 14 ft·lb)+150°</b></p>
---	---



ECA14980

**CAUTION:**

**Tighten the connecting rod bolts using the plastic-region tightening angle method.**

- Clean the connecting rod bolts.
- Tighten the connecting rod bolts.
- Put a mark "1" on the connecting rod bolt "2" and the connecting rod cap "3".

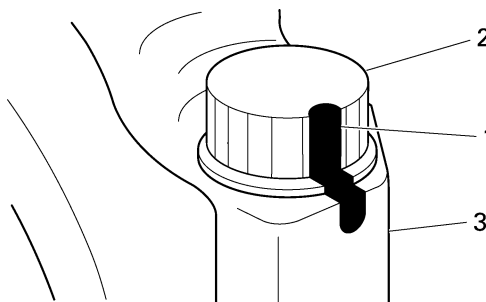

- Tighten the bolt further to reach the specified angle (150°).

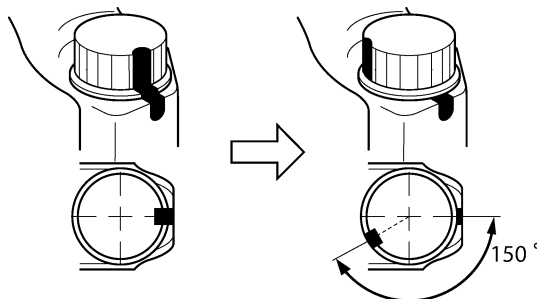

- After the installation, check that the section shown "a" is flush with each other by touching the surface.

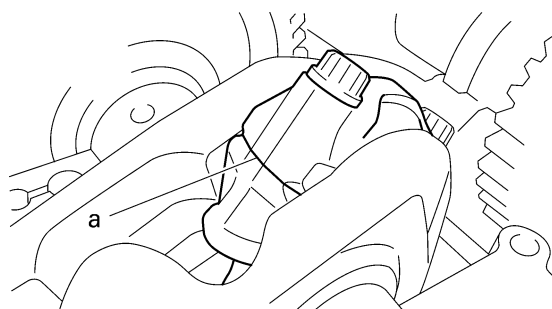

a. Side machined face

EWA13990

**WARNING**

- When the bolt is tightened more than the specified angle, do not loosen the bolt and then retighten it. Replace the bolt with a new one and perform the procedure again.

# CRANKSHAFT

- If they are not flush with each other, remove the connecting rod bolt and big end bearing and restart from step "9". In this case, make sure to replace the connecting rod bolt.

ECA14680

**CAUTION:** \_\_\_\_\_

- Do not use a torque wrench to tighten the bolt to the specified angle.
- Tighten the bolt until it is at the specified angles.



EAS4C81016

**CHECKING THE CRANKSHAFT**

1. Measure:
  - Crankshaft runout  
Out of specification → Replace the crankshaft.

	<p><b>Crankshaft runout</b> Less than 0.03 mm (0.0012 in)</p>
--	---

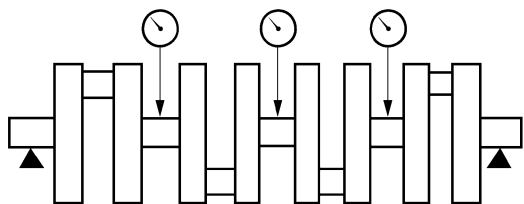

11631006

2. Check:
  - Crankshaft journal surfaces
  - Crankshaft pin surfaces
  - Bearing surfaces  
Scratches/wear → Replace the crankshaft.

EAS4C81017

**CHECKING THE CRANKSHAFT DRIVE SPROCKET**

1. Check:
  - Crankshaft drive sprocket "1"  
Cracks/damage/wear → Replace the defective part(s).

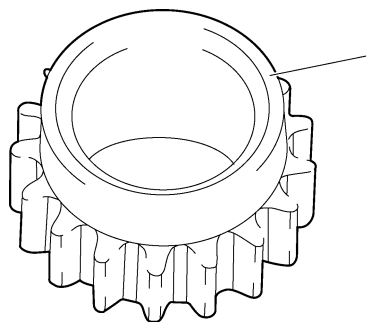

EAS4C81018

**CHECKING THE CRANKSHAFT JOURNAL BEARINGS**

1. Measure:
  - Crankshaft-journal-to-crankshaft-journal bearing clearance  
Out of specification → Replace the crankshaft journal bearings.

	<p><b>Crankshaft-journal-to-crankshaft-journal bearing clearance</b> 0.014-0.037 mm (0.0006-0.0015 in) <b>Limit</b> 0.10 mm (0.0039 in)</p>
--	---

ECA4C81011

**CAUTION:** \_\_\_\_\_

**Do not interchange the crankshaft journal bearings. To obtain the correct crankshaft-journal-to-crankshaft-journal bearing clearance and prevent engine damage, the crankshaft journal bearings must be installed in their original positions.**



- a. Clean the crankshaft journal bearings, crankshaft journals, and bearing portions of the crankcase.
- b. Place the upper crankcase upside down on a bench.
- c. Install the crankshaft journal upper bearings "1" and the crankshaft into the upper crankcase.

**NOTE:** \_\_\_\_\_

Align the projections "a" on the crankshaft journal upper bearings with the notches "b" in the upper crankcase.

## CRANKSHAFT

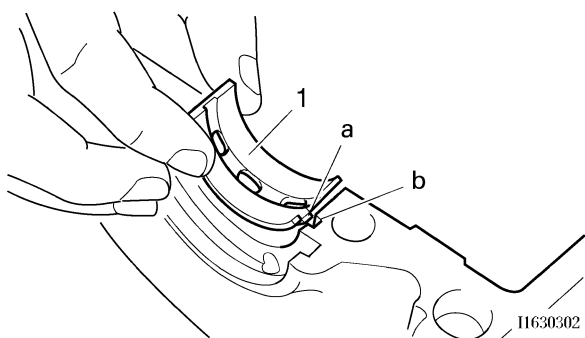

d. Put a piece of Plastigauge® “2” on each crankshaft journal.

**NOTE:**

Do not put the Plastigauge® over the oil hole in the crankshaft journal.

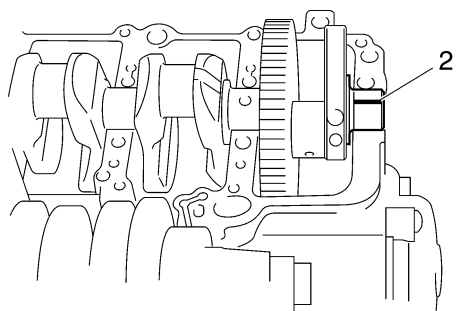

e. Install the crankshaft journal lower bearings “1” into the lower crankcase and assemble the crankcase halves.

**NOTE:**

- Align the projections “a” of the crankshaft journal lower bearings with the notches “b” in the lower crankcase.
- Do not move the crankshaft until the clearance measurement has been completed.

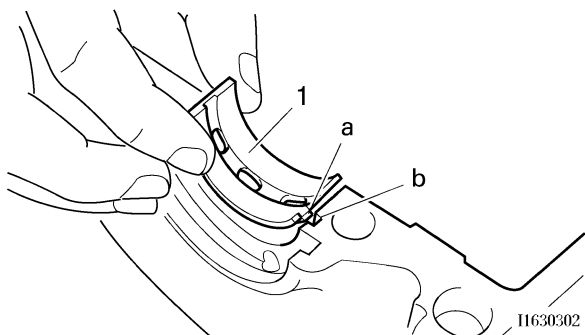

f. Tighten the bolts to specification in the tightening sequence cast on the crankcase.



**Crankcase bolt**

**Bolt “1”–“10”**

**1st: 20 Nm (2.0 m·kg, 14 ft·lb)**

**2nd: 20 Nm (2.0 m·kg, 14 ft·lb)**

**3rd: +60°**

**Bolt “11”–“16”**

**24 Nm (2.4m·kg, 17 ft·lb)**

**Bolt “17”–“26”**

**10 Nm (1.0m·kg, 7.2 ft·lb)**

M9 x 105 mm (4.1 in) bolts: “1”–“10”

M8 x 60 mm (2.4 in) bolt: “11” LOCTITE®

M8 x 60 mm (2.4 in) bolts: “12”, “16”

M8 x 50 mm (2.0 in) bolts: “13”–“15”

M6 x 65 mm (2.5 in) bolts: “17”, “18”

M6 x 70 mm (2.8 in) bolts: “19”, “21”, “23”

M6 x 50 mm (2.0 in) bolts: “20”, “26”

M6 x 60 mm (2.4 in) bolt and washer: “22”

M6 x 60 mm (2.4 in) bolts: “24”, “25”

\* Following the tightening order, loosen the bolt one by one and then retighten it to the specific torque.

**NOTE:**

Lubricate the crankcase bolt threads with engine oil.

Refer to "CRANKCASE" on page 5-65.

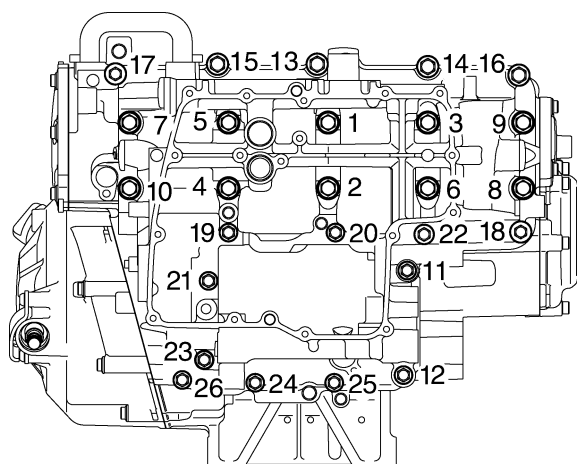

g. Remove the lower crankcase and the crankshaft journal lower bearings.

h. Measure the compressed Plastigauge® width “c” on each crankshaft journal. If the crankshaft-journal-to-crankshaft-journal bearing clearance is out of specification, select replacement crankshaft journal bearings.

# CRANKSHAFT

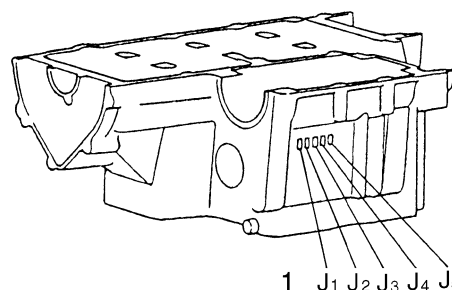
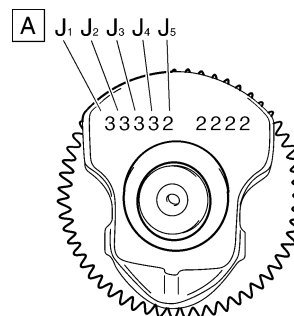
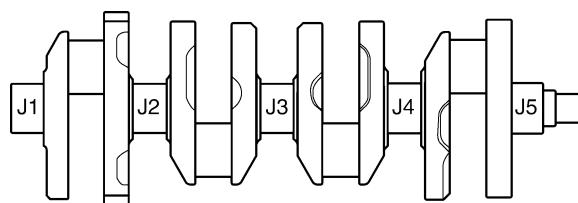
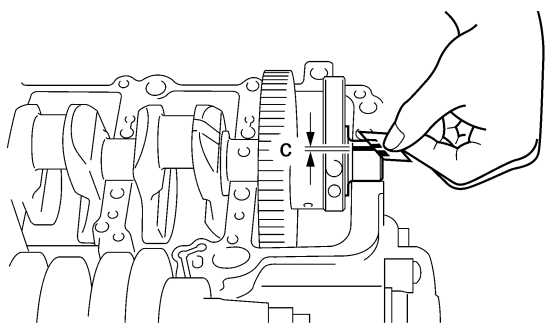

2. Select:
- Crankshaft journal bearings (J1–J5)

**NOTE:**

- The numbers “A” stamped into the crankshaft web and the numbers “1” stamped into the lower crankcase are used to determine the replacement crankshaft journal bearing sizes.
- “J1–J5” refer to the bearings shown in the crankshaft illustration.
- If “J1–J5” are the same, use the same size for all of the bearings.
- If the size is the same for all “J<sub>1</sub> to J<sub>5</sub>” one digit for that size is indicated. (Crankcase side only)

For example, if the crankcase “J<sub>1</sub>” and crankshaft web “J<sub>1</sub>” numbers are “6” and “2” respectively, then the bearing size for “J<sub>1</sub>” is:

“J<sub>1</sub>” (crankcase) – “J<sub>1</sub>”  
 (crankshaft web) – 1 =  
 6 – 2 – 1 = 3 (brown)

CRANKSHAFT JOURNAL BEARING COLOR CODE	
0	White
1	Blue
2	Black
3	Brown
4	Green

EAS26200

**INSTALLING THE CRANKSHAFT**

1. Install:
- Crankshaft journal upper bearings “1” (into the upper crankcase)

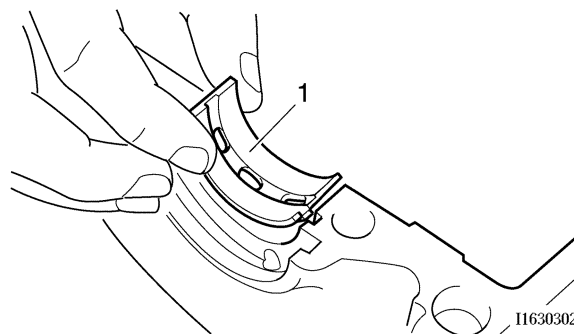

2. Lubricate:
- Crankshaft journal upper bearings (with the recommended lubricant)

**Recommended lubricant  
Engine oil**

## CRANKSHAFT

**NOTE:**

- Align the projections “a” on the crankshaft journal upper bearings with the notches “b” in the upper crankcase.
- Be sure to install each crankshaft journal upper bearing in its original place.

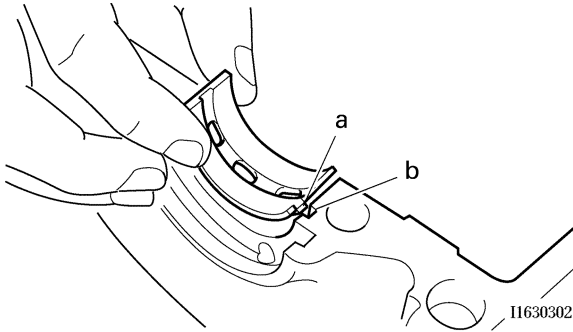

3. Install:
  - Crankshaft
4. Install:
  - Crankcase (lower)  
Refer to "CRANKCASE" on page 5-65.
5. Install:
  - Pin
  - Pickup rotor “1”
  - Drive sprocket “2”

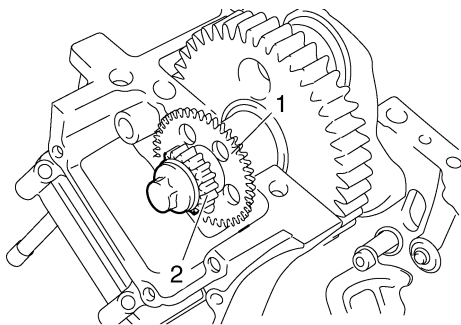

# TRANSMISSION

EAS26240

## TRANSMISSION

Removing the transmission, shift drum assembly, and shift forks

12 Nm (1.2 m·kg, 8.7 ft·lb)

10 Nm (1.0 m·kg, 7.2 ft·lb)

10 Nm (1.0 m·kg, 7.2 ft·lb)

10 Nm (1.0 m·kg, 7.2 ft·lb)

New

Order	Job/Parts to remove	Q'ty	Remarks
	Lower crankcase		Separate. Refer to "CRANKCASE" on page 5-65.
1	Drive axle assembly	1	
2	Circlip	1	
3	Oil seal	1	
4	Bearing	1	
5	Washer	1	
6	Shift fork guide bar retainer	2	
7	Spring	2	
8	Shift fork guide bar	2	
9	Shift fork-L	1	
10	Shift fork-R	1	
11	Shift drum assembly	1	
12	Shift fork-C	1	
13	Main axle retainer	1	
14	Main axle assembly	1	
15	Oil pipe	1	
16	O-ring	2	
17	Oil baffle plate	1	

# TRANSMISSION

## Removing the transmission, shift drum assembly, and shift forks

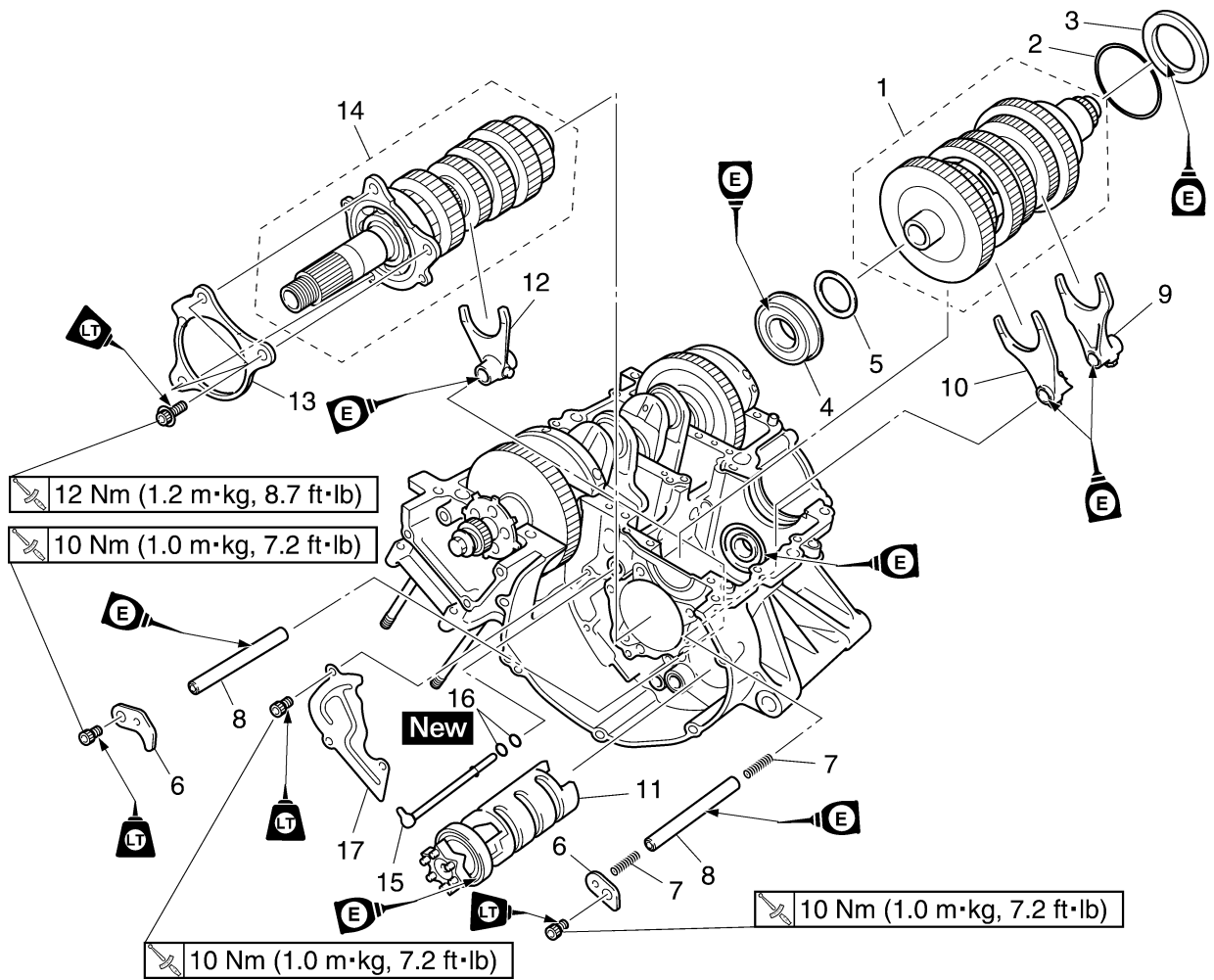

Order	Job/Parts to remove	Q'ty	Remarks
			For installation, reverse the removal procedure.

# TRANSMISSION

## Disassembling the main axle assembly

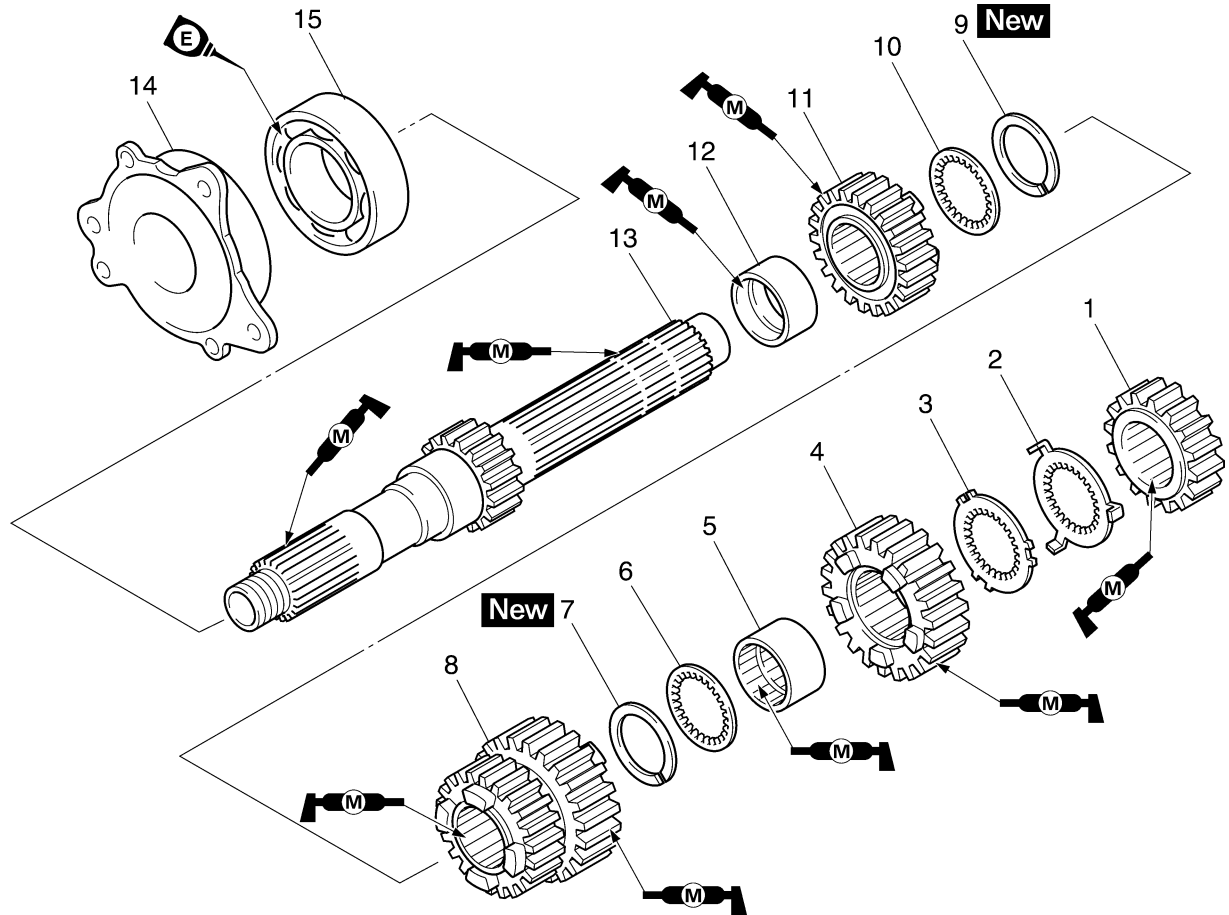

Order	Job/Parts to remove	Q'ty	Remarks
1	2nd pinion gear	1	
2	Toothed lock washer	1	
3	Toothed lock washer retainer	1	
4	6th pinion gear	1	
5	Collar	1	
6	Washer	1	
7	Circlip	1	
8	3rd pinion gear	1	
9	Circlip	1	
10	Washer	1	
11	5th pinion gear	1	
12	Collar	1	
13	Main axle	1	
14	Bearing housing	1	
15	Bearing	1	
			For assembly, reverse the disassembly procedure.

# TRANSMISSION

## Disassembling the drive axle assembly

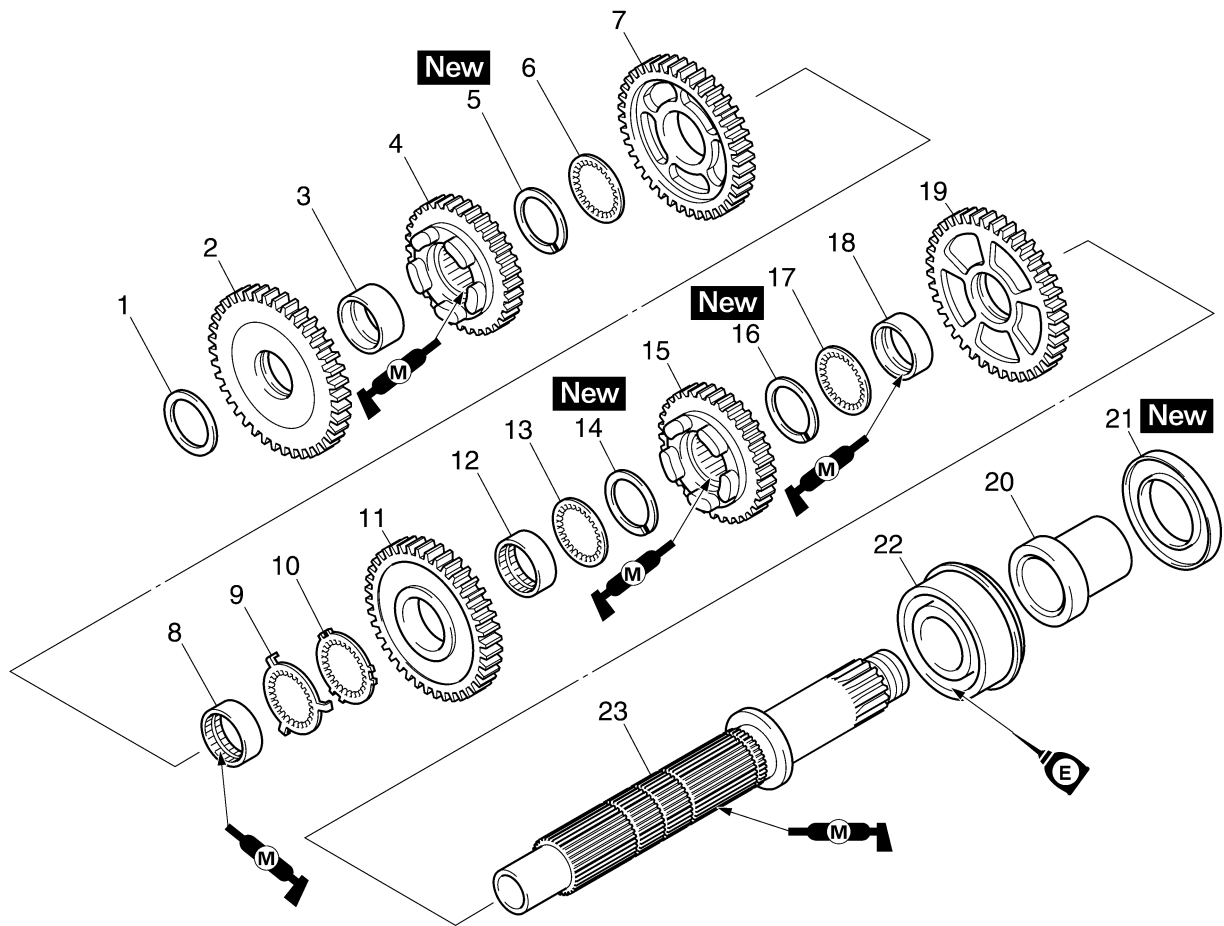

Order	Job/Parts to remove	Q'ty	Remarks
1	Washer	1	
2	1st wheel gear	1	
3	Collar	1	
4	5th wheel gear	1	
5	Circlip	1	
6	Washer	1	
7	3rd wheel gear	1	
8	Collar	1	
9	Toothed lock washer	1	
10	Toothed lock washer retainer	1	
11	4th wheel gear	1	
12	Collar	1	
13	Washer	1	
14	Circlip	1	
15	6th wheel gear	1	
16	Circlip	1	
17	Washer	1	
18	Collar	1	
19	2nd wheel gear	1	
20	Collar	1	
21	Oil seal	1	
22	Bearing	1	
23	Drive axle	1	

# TRANSMISSION

**Disassembling the drive axle assembly**

Order	Job/Parts to remove	Q'ty	Remarks
			For assembly, reverse the disassembly procedure.

# TRANSMISSION

EAS26250

## REMOVING THE TRANSMISSION

1. Remove:
  - Drive axle assembly "1"
  - Shift drum retainers "2"
  - Shift fork guide bars
  - Shift fork "L" and "R"
  - Shift drum assembly
  - Shift fork "C"

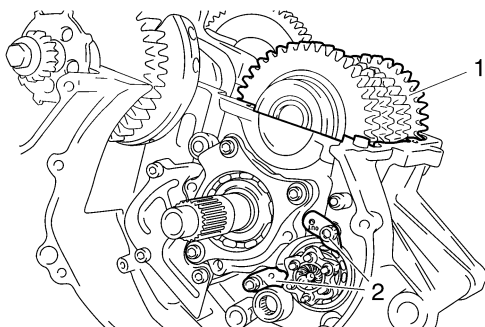
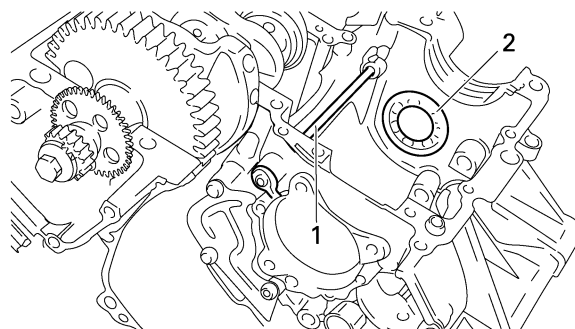

2. Remove:
  - Bearing housing "1"
  - Main axle assembly "2"



- a. Insert two bolts "3" of the proper size, as shown in the illustration, into the main axle assembly bearing housing.

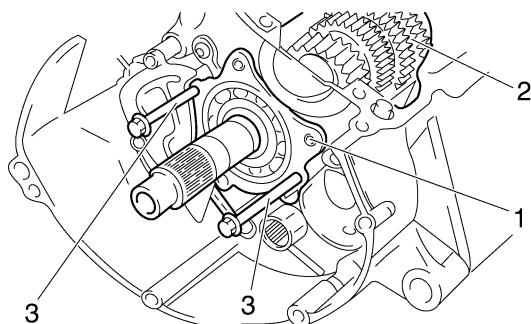

- b. Tighten the bolts until they contact the crankcase surface.
- c. Continue tightening the bolts until the main axle assembly comes free from the upper crankcase.



3. Remove:
  - Oil pipe "1"
  - Bearing "2"

EAS26260

## CHECKING THE SHIFT FORKS

The following procedure applies to all of the shift forks.

1. Check:
  - Shift fork cam follower "1"
  - Shift fork pawl "2"
 Bends/damage/scoring/wear → Replace the shift fork.

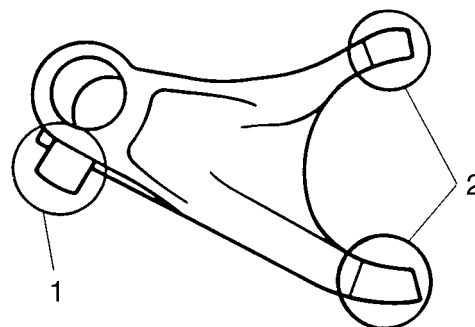

2. Check:
  - Shift fork guide bar
 Roll the shift fork guide bar on a flat surface.  
 Bends → Replace.

EWA12840

**⚠ WARNING**

**Do not attempt to straighten a bent shift fork guide bar.**

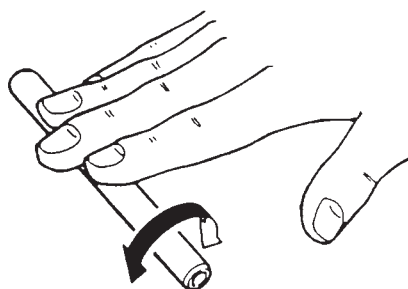

319-010

3. Check:
  - Shift fork movement (along the shift fork guide bar)

# TRANSMISSION

Rough movement → Replace the shift forks and shift fork guide bar as a set.

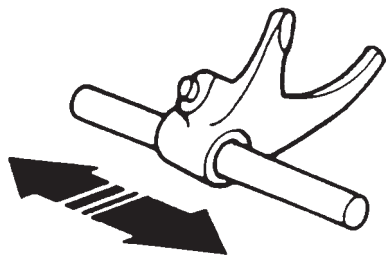

319-011

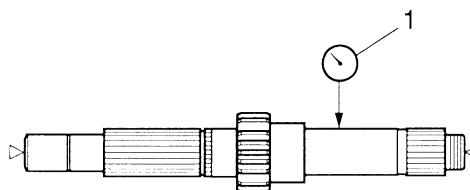

H650702

EAS26270

## CHECKING THE SHIFT DRUM ASSEMBLY

1. Check:
  - Shift drum groove  
Damage/scratches/wear → Replace the shift drum assembly.
  - Shift drum segment "1"  
Damage/wear → Replace the shift drum assembly.
  - Shift drum bearing "2"  
Damage/pitting → Replace the shift drum assembly.

2. Measure:
  - Drive axle runout  
(with a centering device and dial gauge "1")  
Out of specification → Replace the drive axle.

	<b>Drive axle runout limit</b> <b>0.08 mm (0.0032 in)</b>
--	--

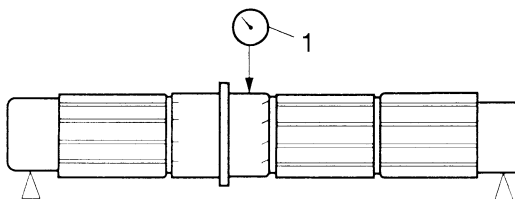
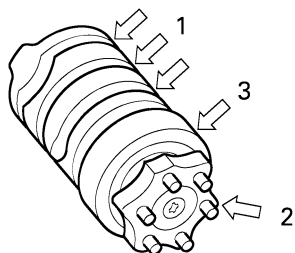

H650701

EAS26300

## CHECKING THE TRANSMISSION

1. Measure:
  - Main axle runout  
(with a centering device and dial gauge "1")  
Out of specification → Replace the main axle.

3. Check:
  - Transmission gears  
Blue discoloration/pitting/wear → Replace the defective gear(s).
  - Transmission gear dogs  
Cracks/damage/rounded edges → Replace the defective gear(s).

	<b>Main axle runout limit</b> <b>0.08 mm (0.0032 in)</b>
--	---

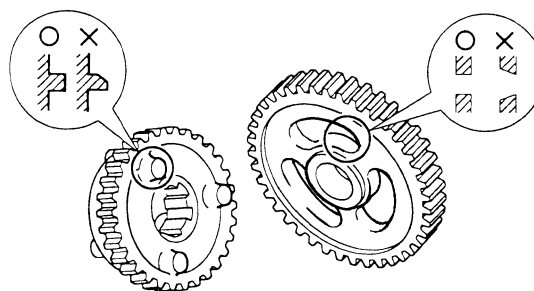

# TRANSMISSION

EAS26350

## INSTALLING THE TRANSMISSION

### 1. Install:

- Bearing "1"

### NOTE:

Make the seal side of bearing face to the outside and install it close to the right end face of the crankcase.

- Oil pipe "2"

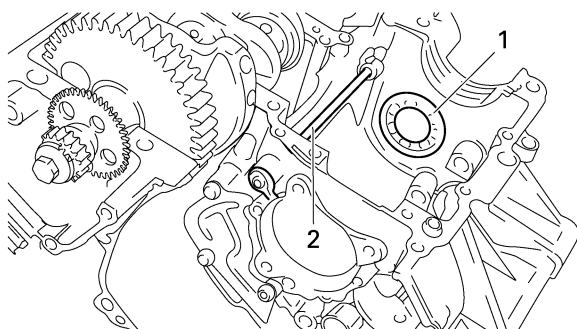

### 2. Install:

- Main axle assembly "1"
- Bearing housing "2"



**Bearing housing bolt**  
**12 Nm (1.2 m·kg, 8.7 ft·lb)**  
**LOCTITE®**

- Shift fork "C"
- Shift drum assembly
- Shift fork guide bar
- Shift fork guide bar retainer



**Shift fork guide bar retainer bolt**  
**10 Nm (1.0 m·kg, 7.2 ft·lb)**  
**LOCTITE®**

### NOTE:

- The embossed marks on the shift forks should face towards the right side of the engine and be in the following sequence: "R", "C", "L".
- Carefully position the shift forks so that they are installed correctly into the transmission gears.
- Install shift fork "C" into the groove in the 3rd and 4th pinion gear on the main axle.

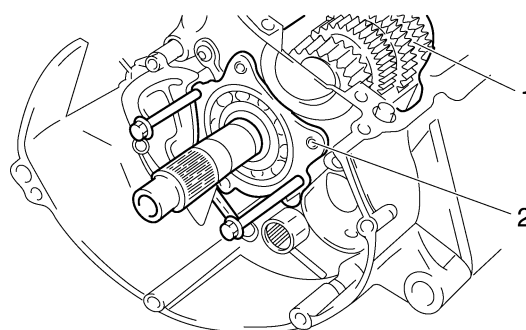

### 3. Install:

- Shift fork "L" "1" and "R" "2"
- Drive axle assembly "3"
- Shift fork guide bar
- Shift fork guide bar retainer "4"

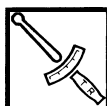

**Shift fork guide bar retainer bolt**  
**10 Nm (1.0 m·kg, 7.2 ft·lb)**  
**LOCTITE®**

### NOTE:

- Install shift fork "L" into the groove in the 6th wheel gear and shift fork "R" into the groove in the 5th wheel gear on the drive axle.
- Make sure that the drive axle bearing circlip "a" is inserted into the grooves in the upper crankcase.

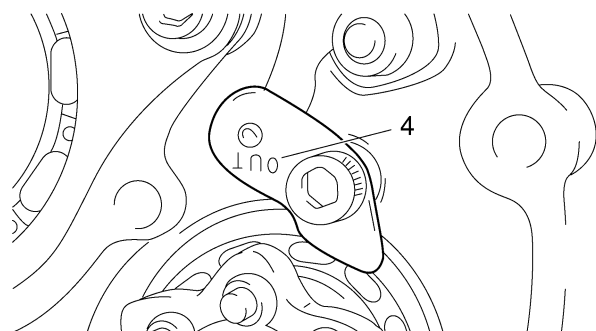
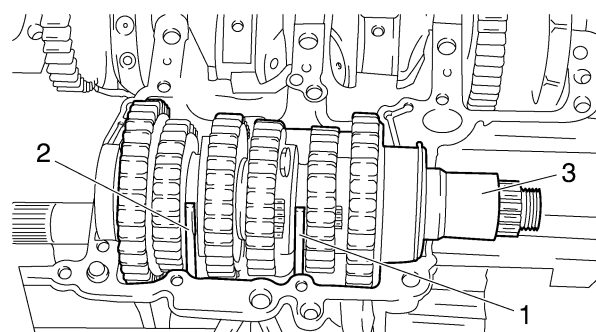

## TRANSMISSION

---

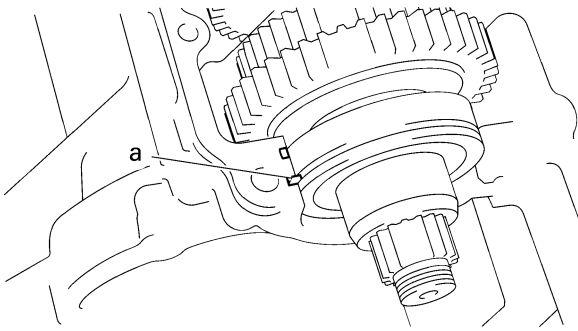

4. Check:

- Transmission  
Rough movement → Repair.

**NOTE:** \_\_\_\_\_  
Oil each gear, shaft, and bearing thoroughly.

---

## **TRANSMISSION**

---

---

## COOLING SYSTEM

<b>RADIATOR</b> .....	6-1
CHECKING THE RADIATOR.....	6-3
INSTALLING THE RADIATOR.....	6-3
<b>OIL COOLER</b> .....	6-4
CHECKING THE OIL COOLER.....	6-5
INSTALLING THE OIL COOLER.....	6-5
<b>THERMOSTAT</b> .....	6-6
CHECKING THE THERMOSTAT.....	6-8
ASSEMBLING THE THERMOSTAT ASSEMBLY.....	6-8
INSTALLING THE THERMOSTAT ASSEMBLY.....	6-8
<b>WATER PUMP</b> .....	6-9
DISASSEMBLING THE WATER PUMP.....	6-10
CHECKING THE WATER PUMP.....	6-10
ASSEMBLING THE WATER PUMP.....	6-10

# RADIATOR

EAS26380

## RADIATOR

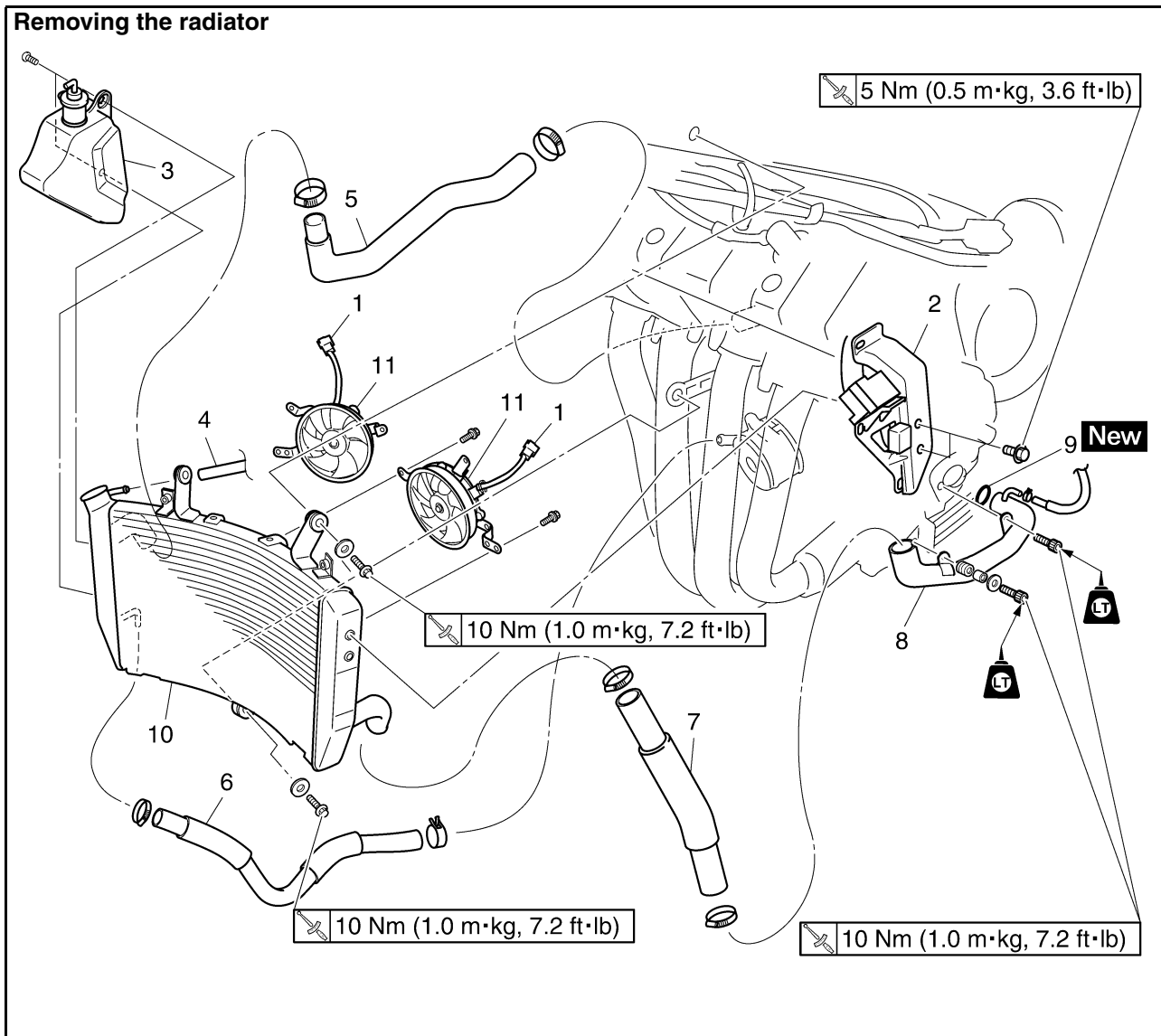

Order	Job/Parts to remove	Q'ty	Remarks
	Rider seat		Refer to "GENERAL CHASSIS" on page 4-1.
	Side cowling		Refer to "GENERAL CHASSIS" on page 4-1.
	Coolant		Drain. Refer to "CHANGING THE COOLANT" on page 3-20.
	Fuel tank		Refer to "FUEL TANK" on page 7-1.
	Air filter case		Refer to "GENERAL CHASSIS" on page 4-1.
1	Radiator fan coupler	2	Disconnect.
2	Fuse holder stay	1	
3	Coolant reservoir tank	1	
4	Coolant reservoir hose	1	
5	Radiator inlet hose	1	
6	Oil cooler outlet hose	1	
7	Radiator outlet hose	1	
8	Water pump inlet pipe	1	
9	O-ring	1	
10	Radiator	1	

# RADIATOR

## Removing the radiator

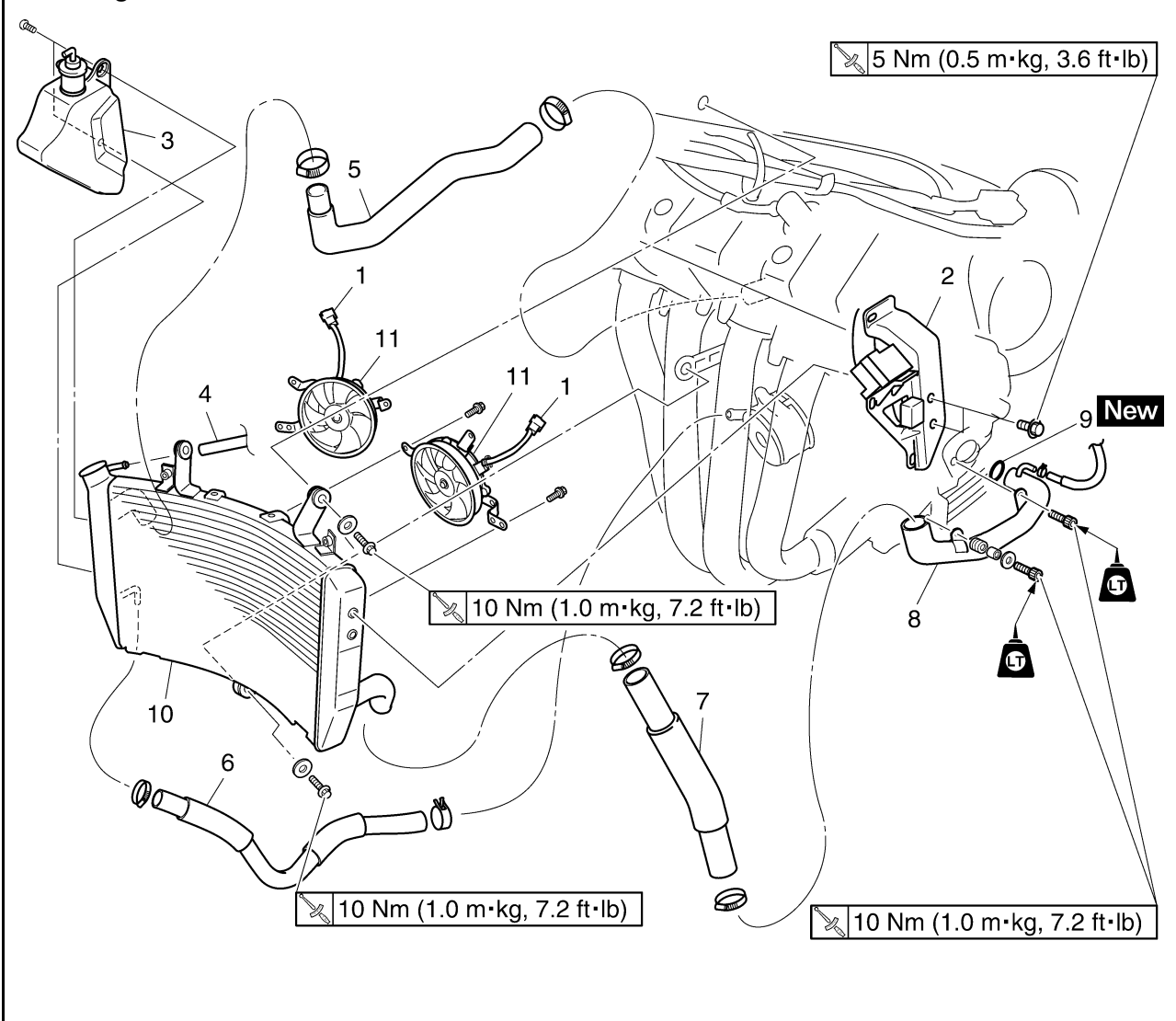

Order	Job/Parts to remove	Q'ty	Remarks
11	Radiator fan motor	2	
			For installation, reverse the removal procedure.



# OIL COOLER

EAS26410

## OIL COOLER

### Removing the oil cooler

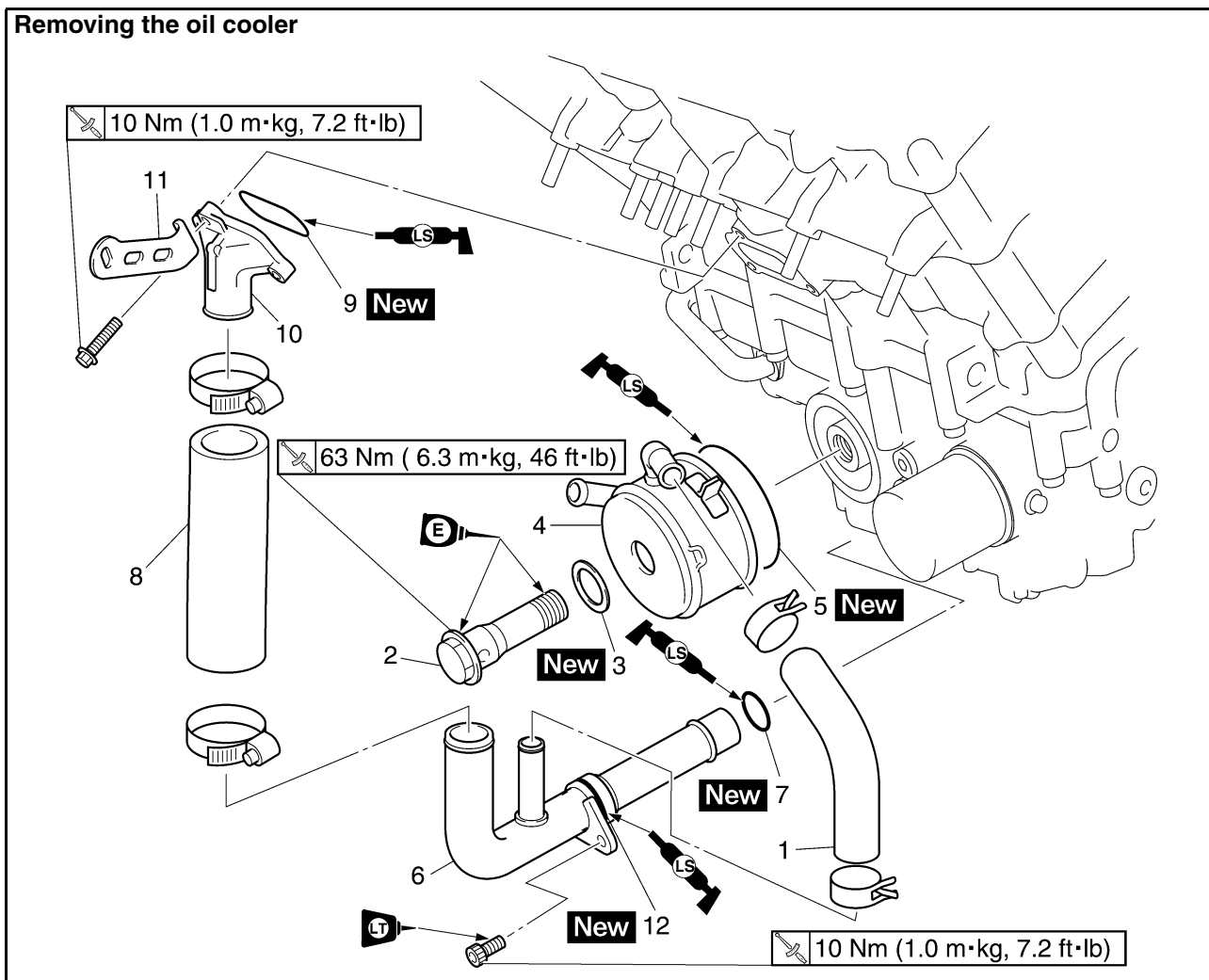

Order	Job/Parts to remove	Q'ty	Remarks
	Engine oil		Drain. Refer to "CHANGING THE ENGINE OIL" on page 3-12.
	Coolant		Drain. Refer to "CHANGING THE COOLANT" on page 3-20.
1	Oil cooler inlet hose	1	
2	Oil cooler bolt	1	Loosen.
3	Washer	1	Disconnect.
4	Oil cooler	1	Disconnect.
5	O-ring	1	
6	Water pump outlet pipe	1	
7	O-ring	1	
8	Water jacket joint inlet hose	1	
9	O-ring	1	
10	Water jacket joint	1	
11	Stay	1	
12	O-ring	1	
			For installation, reverse the removal procedure.

## OIL COOLER

EAS26420

### CHECKING THE OIL COOLER

1. Check:
  - Oil cooler  
Cracks/damage → Replace.

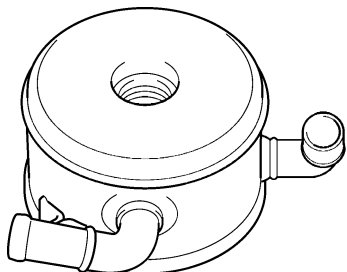

2. Check:
  - Oil cooler inlet hose
  - Oil cooler outlet hose  
Cracks/damage/wear → Replace.

EAS26430

### INSTALLING THE OIL COOLER

1. Clean:
  - Mating surfaces of the oil cooler and the crankcase  
(with a cloth dampened with lacquer thinner)
2. Install:
  - O-ring **New**
  - Oil cooler "1"
  - Washer "2" **New**
  - Oil cooler bolt "3"

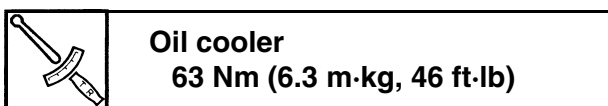

#### NOTE:

- Before installing the oil cooler, lubricate the oil cooler bolt and O-ring with a thin coat of engine oil.
- Make sure the O-ring is positioned properly.
- Align the projection "a" on the oil cooler with the slot "b" in the crankcase.

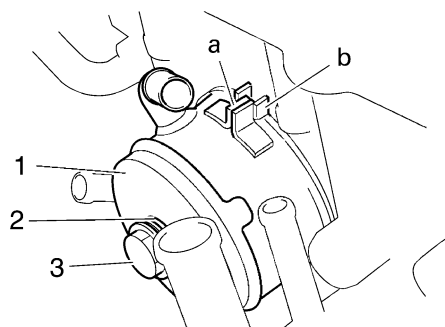

3. Fill:
  - Cooling system  
(with the specified amount of the recommended coolant)  
Refer to "CHANGING THE COOLANT" on page 3-20.
  - Crankcase  
(with the specified amount of the recommended engine oil)  
Refer to "CHANGING THE ENGINE OIL" on page 3-12.
4. Check:
  - Cooling system  
Leaks → Repair or replace any faulty part.

# THERMOSTAT

EAS26440

## THERMOSTAT

### Removing the thermostat assembly

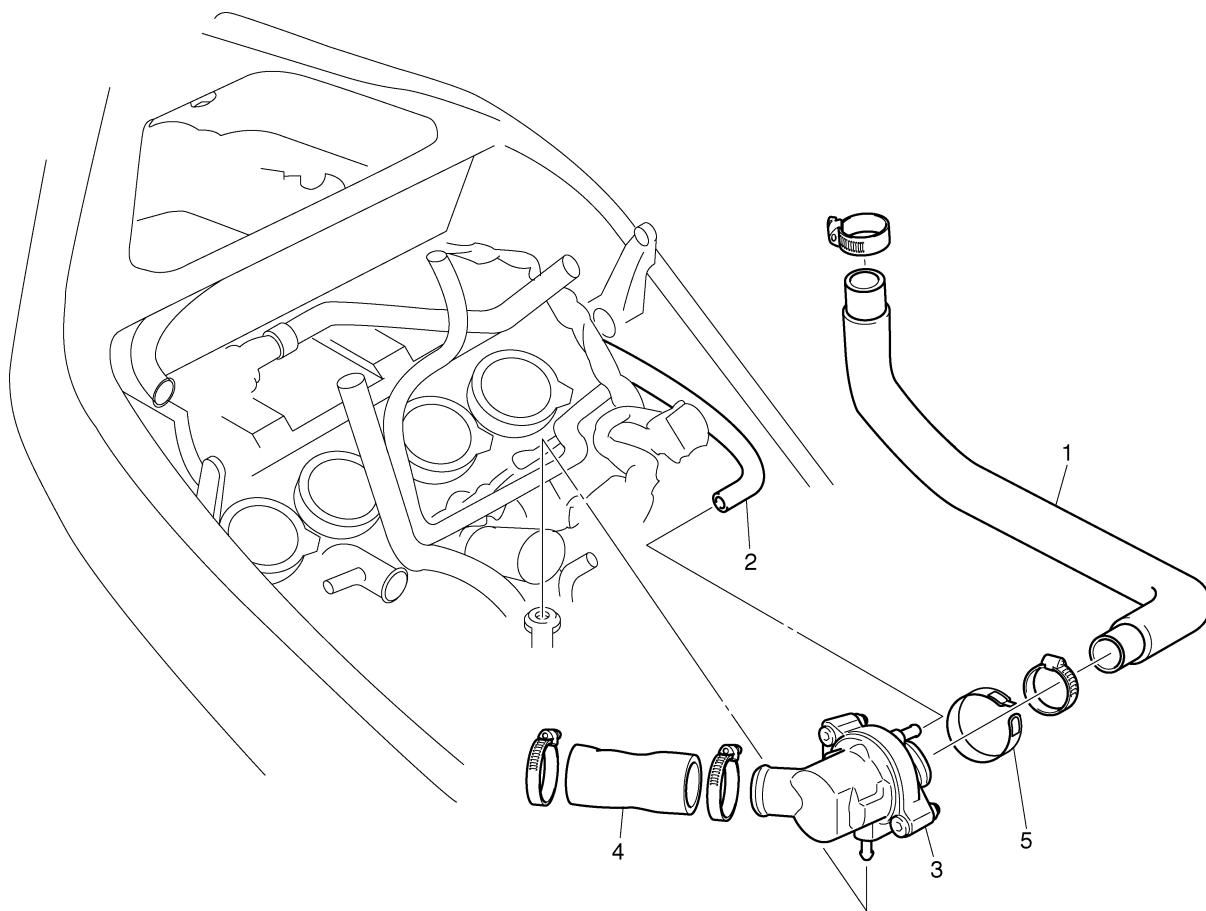

Order	Job/Parts to remove	Q'ty	Remarks
	Rider seat		Refer to "GENERAL CHASSIS" on page 4-1.
	Fuel tank		Refer to "FUEL TANK" on page 7-1.
	Air filter case		Refer to "GENERAL CHASSIS" on page 4-1.
	Coolant		Refer to "CHANGING THE COOLANT" on page 3-20.
1	Thermostat assembly outlet hose	1	
2	Thermostat assembly breather hose	1	
3	Thermostat assembly	1	
4	Thermostat assembly inlet hose	1	
5	Band	1	
			For installation, reverse the removal procedure.

# THERMOSTAT

## Disassembling the thermostat assembly

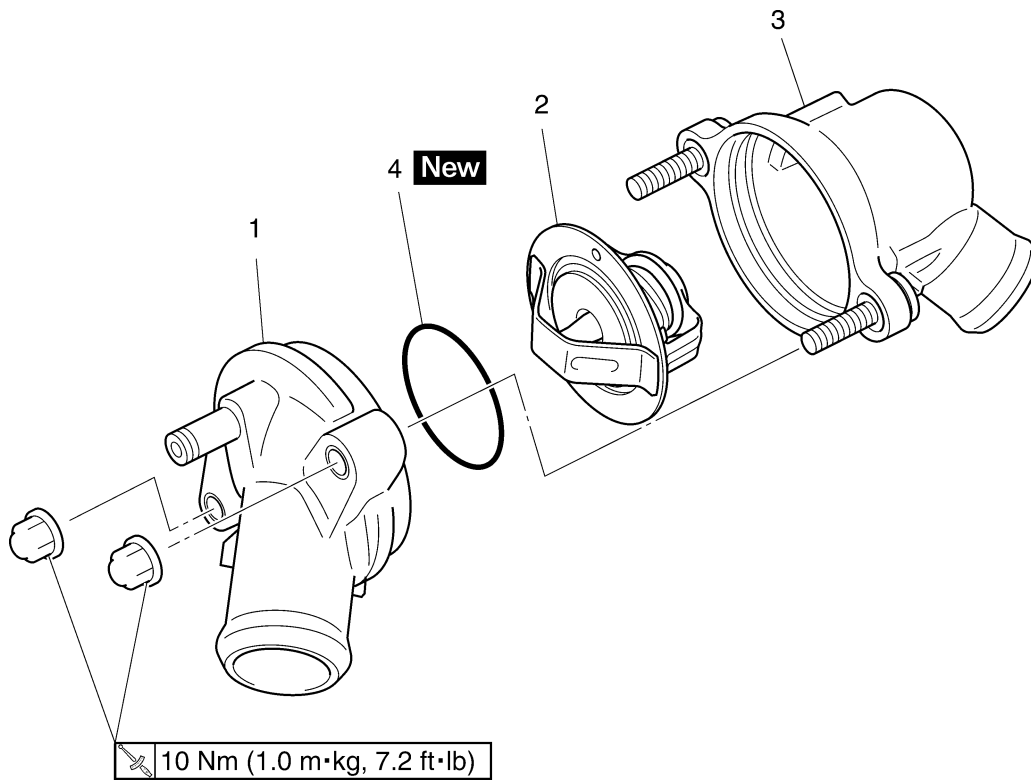

Order	Job/Parts to remove	Q'ty	Remarks
1	Thermostat housing cover	1	
2	Thermostat	1	
3	Thermostat housing	1	
4	O-ring	1	
			For assembly, reverse the disassembly procedure.

# THERMOSTAT

EAS26450

## CHECKING THE THERMOSTAT

1. Check:

- Thermostat  
Does not open at 71–85°C (160–185°F) → Replace.

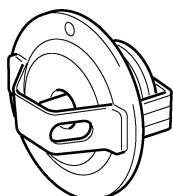

2. Check:

- Thermostat housing cover “1”
- Thermostat housing “2”  
Cracks/damage → Replace.

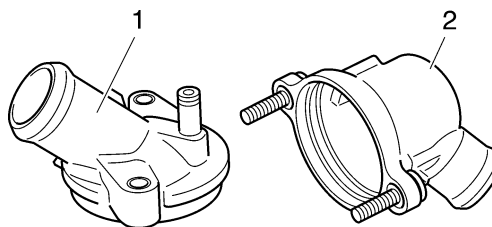

EAS26460

## ASSEMBLING THE THERMOSTAT ASSEMBLY

1. Install:

- Thermostat housing “1”
- Thermostat “2”
- O-ring “3” **New**
- Thermostat housing cover “4”

	<b>Thermostat housing cover nut 10 Nm (1.0 m·kg, 7.2 ft·lb)</b>
--	---

**NOTE:**

Install the thermostat with its breather hole “a” facing up.



- Suspend the thermostat “1” in a container “2” filled with water.
- Slowly heat the water “3”.
- Place a thermometer “4” in the water.
- While stirring the water, observe the thermostat and thermometer’s indicated temperature.

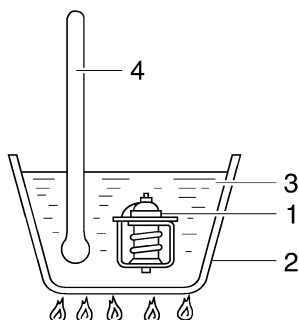

14250201

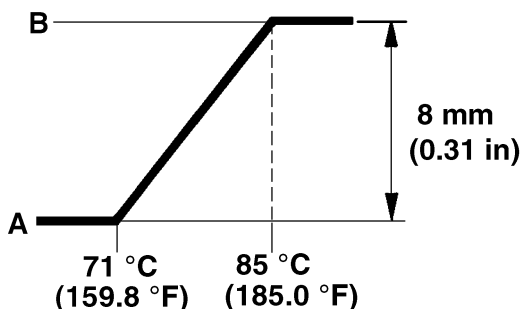

- A. Fully closed
- B. Fully open

**NOTE:**

If the accuracy of the thermostat is in doubt, replace it. A faulty thermostat could cause serious overheating or over cooling.

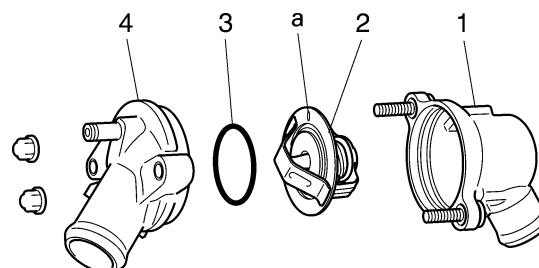

EAS26480

## INSTALLING THE THERMOSTAT ASSEMBLY

1. Fill:

- Cooling system  
(with the specified amount of the recommended coolant)  
Refer to "CHANGING THE COOLANT" on page 3-20.

2. Check:

- Cooling system  
Leaks → Repair or replace any faulty part.



# WATER PUMP

EAS26500

## WATER PUMP

### Disassembling the water pump

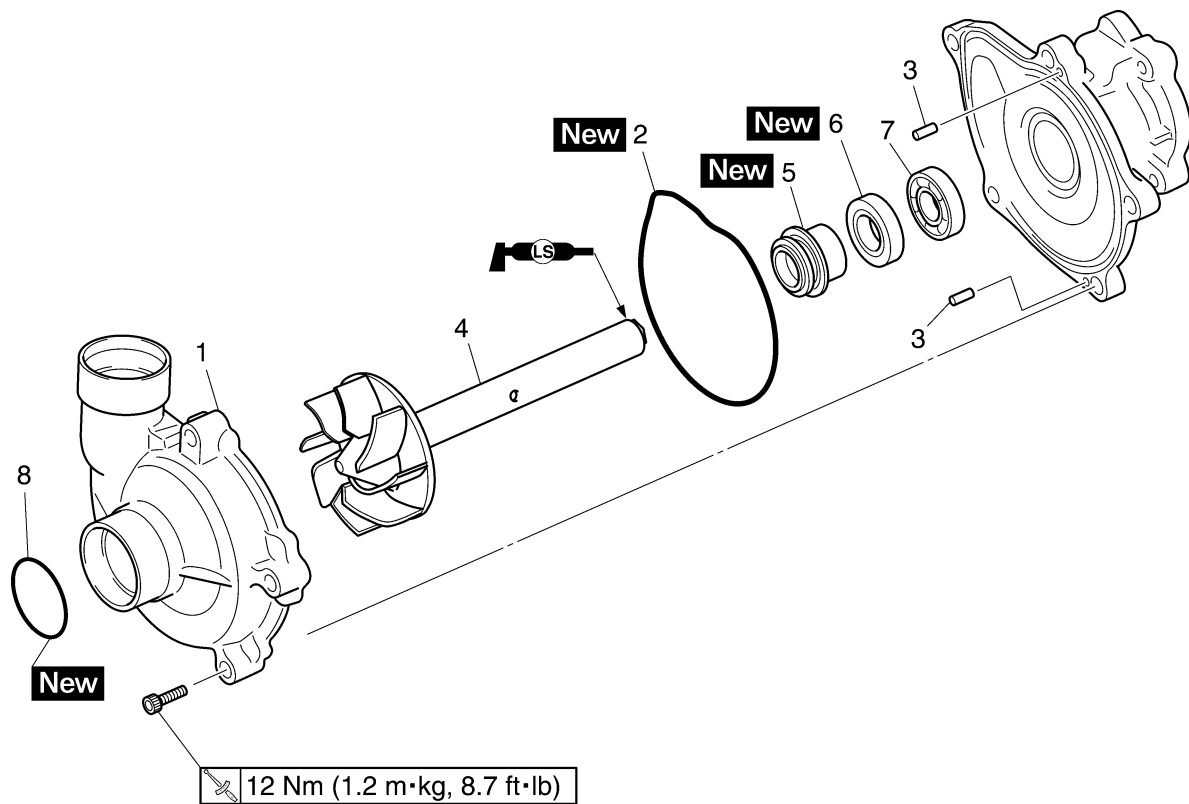

12 Nm (1.2 m·kg, 8.7 ft·lb)

Order	Job/Parts to remove	Q'ty	Remarks
	Oil/water pump assembly		Refer to "OIL PUMP" on page 5-57.
	Oil pump rotor		Refer to "OIL PUMP" on page 5-57.
1	Water pump cover	1	
2	O-ring	1	
3	Pin	2	
4	Impeller shaft (along with the impeller)	1	
5	Water pump seal	1	
6	Oil seal	1	
7	Bearing	1	
8	O-ring	1	
			For installation, reverse the removal procedure.

## WATER PUMP

EAS26520

### DISASSEMBLING THE WATER PUMP

1. Remove:
  - Water pump seal "1"
  - Water pump housing "2"

**NOTE:** \_\_\_\_\_

Tap out the bearing and oil seal from the outside of the water pump housing.

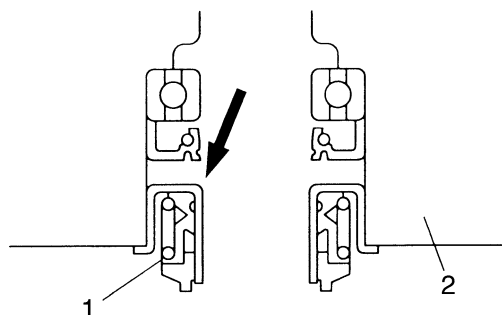

2. Remove:
  - Oil seal "1"
  - Bearing "2"
  - Water pump housing "3"

**NOTE:** \_\_\_\_\_

Tap out the bearing and oil seal from the outside of the water pump housing.

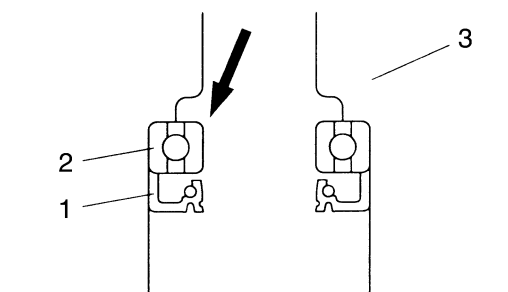

3. Remove:
  - Rubber damper holder "1"
  - Rubber damper "2"
  - (from the impeller, with a thin, flat-head screwdriver)

**NOTE:** \_\_\_\_\_

Do not scratch the impeller shaft.

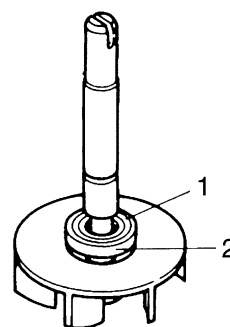

EAS26540

### CHECKING THE WATER PUMP

1. Check:
  - Water pump housing cover "1"
  - Water pump housing "2"
  - Impeller shaft "3"
  - Rubber damper "4"
  - Rubber damper holder "5"
  - Water pump seals
  - Oil seal

Cracks/damage/wear → Replace.

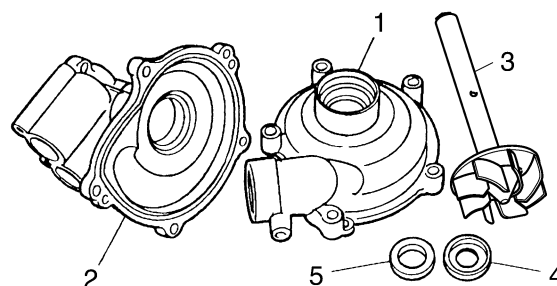

2. Check:
  - Bearing
  - Rough movement → Replace.
3. Check:
  - Water pump outlet pipe
  - Radiator outlet hose
  - Cracks/damage/wear → Replace.

EAS26560

### ASSEMBLING THE WATER PUMP

1. Install:
  - Oil seal "1" **New**
  - (into the water pump housing "2")

**NOTE:** \_\_\_\_\_

- Before installing the oil seal, apply tap water or coolant onto its out surface.
- Install the oil seal with a socket that matches its outside diameter.

# WATER PUMP

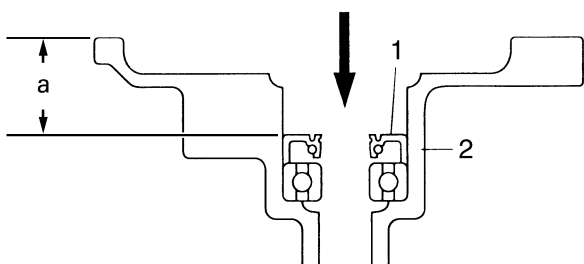

a. 17.2 mm (0.68 in)

2. Install:

- Water pump seal "1" **New**

ECA14080

**CAUTION:**

**Never lubricate the water pump seal surface with oil or grease.**

**NOTE:**

- Install the water pump seal with the special tools.
- Before installing the water pump seal, apply Yamaha bond No.1215 (Three Bond No.1215®) "2" to the water pump housing "3".



**Mechanical seal installer "4"**  
**90890-04078**  
**Water pump seal installer**  
**YM-33221-A**  
**Middle driven shaft bearing**  
**driver "5"**  
**90890-04058**  
**Bearing driver 40 mm**  
**YM-04058**  
**Yamaha bond No. 1215 (Three**  
**Bond No.1215®)**  
**90890-85505**

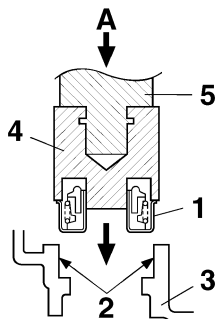

A. Push down

3. Install:

- Rubber damper holder "1" **New**
- Rubber damper "2" **New**

**NOTE:**

Before installing the rubber damper, apply tap water or coolant onto its outer surface.

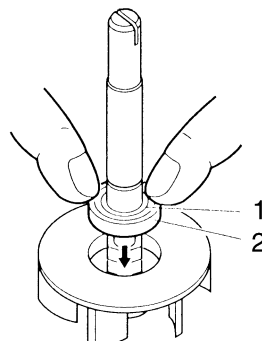

14150204

4. Measure:

- Impeller shaft tilt  
 Out of specification → Repeat steps (3) and (4).

ECA14090

**CAUTION:**

**Make sure the rubber damper and rubber damper holder are flush with the impeller.**



**Impeller shaft tilt limit**  
**0.15 mm (0.006 in)**

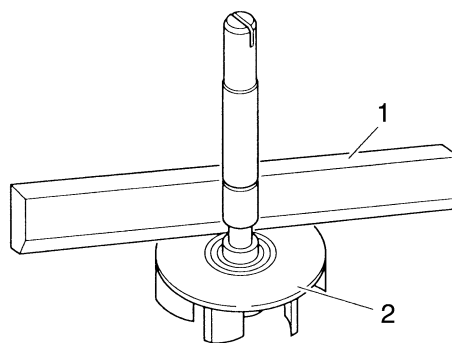

14150203

1. Straightedge
2. Impeller

## FUEL SYSTEM

<b>FUEL TANK</b> .....	7-1
REMOVING THE FUEL TANK .....	7-2
REMOVING THE FUEL PUMP .....	7-2
CHECKING THE FUEL PUMP BODY .....	7-2
CHECKING THE FUEL PUMP OPERATION .....	7-2
INSTALLING THE FUEL PUMP .....	7-2
INSTALLING THE FUEL TANK .....	7-3
<b>THROTTLE BODIES</b> .....	7-4
CHECKING THE INJECTORS .....	7-6
CHECKING THE THROTTLE BODIES .....	7-6
CHECKING THE FUEL PRESSURE .....	7-6
ADJUSTING THE THROTTLE POSITION SENSOR (FOR THROTTLE VALVES) .....	7-6
ADJUSTING THE THROTTLE POSITION SENSOR (FOR THROTTLE CABLE PULLEY) .....	7-7
<b>AIR INDUCTION SYSTEM</b> .....	7-9
CHECKING THE AIR INDUCTION SYSTEM .....	7-10

# FUEL TANK

EAS26620

## FUEL TANK

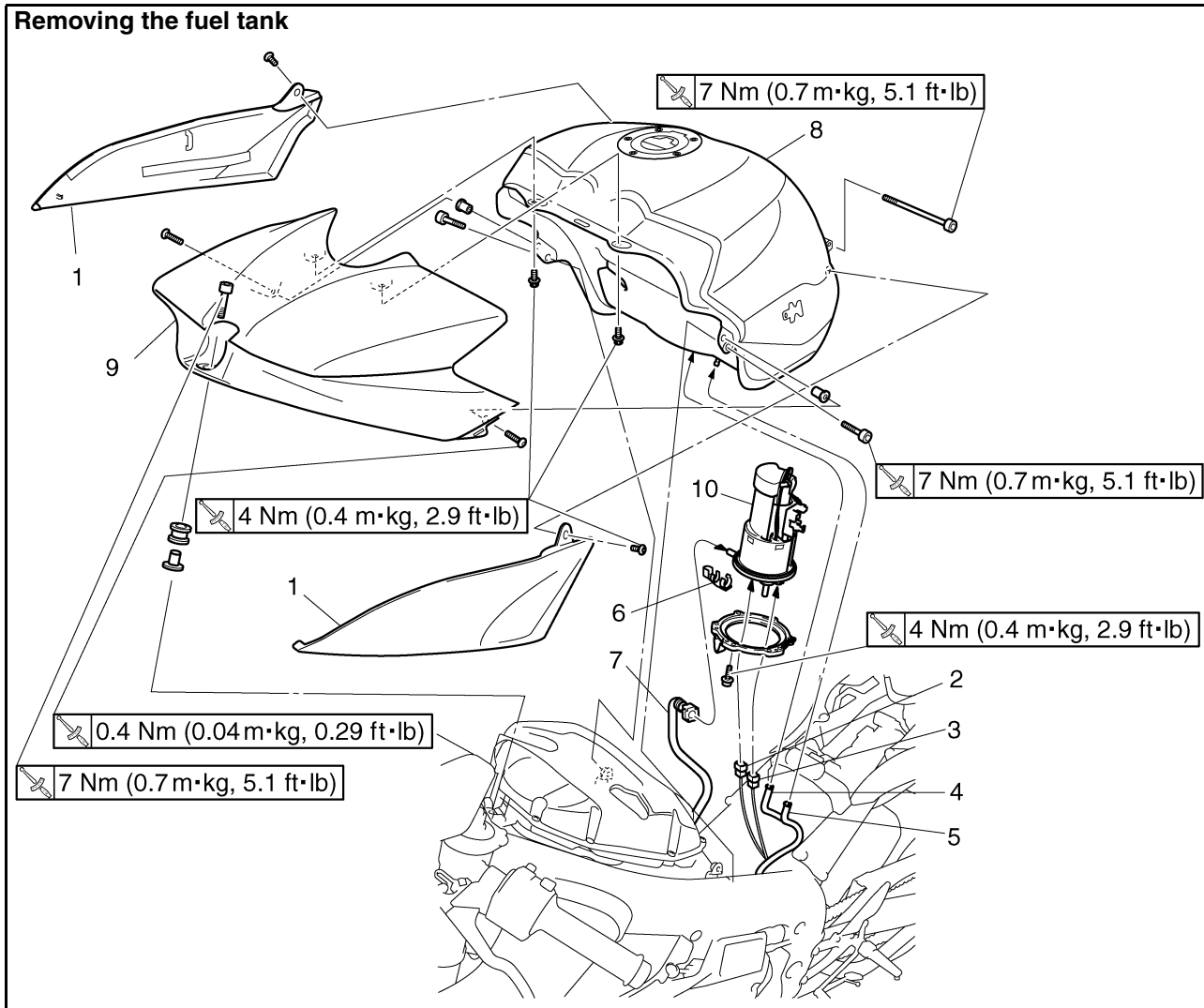

Order	Job/Parts to remove	Q'ty	Remarks
	Rider seat		Refer to "GENERAL CHASSIS" on page 4-1.
	Passenger seat		Refer to "GENERAL CHASSIS" on page 4-1.
1	Fuel tank side cover	2	
2	Fuel sender coupler	1	
3	Fuel pump coupler	1	
4	Fuel tank drain hose	1	
5	Fuel tank breather hose	1	
6	Fuel hose connector	1	
7	Fuel hose	1	
8	Fuel tank	1	
9	Fuel tank top cover	1	
10	Fuel pump	1	
			For installation, reverse the removal procedure.

# FUEL TANK

EAS26630

## REMOVING THE FUEL TANK

1. Extract the fuel in the fuel tank through the fuel tank cap with a pump.
2. Remove:
  - Fuel hose connector cover
  - Fuel hose
  - Fuel sender coupler
  - Fuel pump coupler
  - Fuel tank drain hose
  - Fuel tank breather hose
  - Fuel tank side cover

ECA4C81002

**CAUTION:** \_\_\_\_\_

- **Be sure to disconnect the fuel hose by hand. Do not forcefully disconnect the hose with tools.**
- **Although the fuel has been removed from the fuel tank be careful when removing the fuel hoses, since there may be fuel remaining in it.**

**NOTE:** \_\_\_\_\_

- To remove the fuel hose from the fuel injection pipe, slide the cover "a" on the end of the hose in the direction of the arrow shown and then remove the hose.
- Before removing the hoses, place a few rags in the area under where it will be removed.

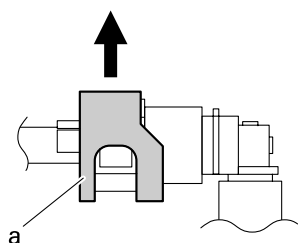

3. Remove:
  - Fuel tank

**NOTE:** \_\_\_\_\_

Do not set the fuel tank down so that the installation surface of the fuel pump is directly under the tank. Be sure to lean the fuel tank in an upright position.

EAS26640

## REMOVING THE FUEL PUMP

1. Remove:
  - Fuel pump

ECA14720

**CAUTION:** \_\_\_\_\_

- **Do not drop the fuel pump or give it a strong shock.**
- **Do not touch the base section of the fuel sender.**

EAS26670

## CHECKING THE FUEL PUMP BODY

1. Check:
  - Fuel pump body  
Obstruction → Clean.  
Cracks/damage → Replace the fuel pump assembly.
2. Check:
  - Diaphragms and gaskets  
Turn/fatigue/cracks → Replace the fuel pump assembly.

EAS26690

## CHECKING THE FUEL PUMP OPERATION

1. Check:
  - Fuel pump operation  
Refer to "CHECKING THE FUEL PRESSURE" on page 7-6.

EAS26710

## INSTALLING THE FUEL PUMP

1. Install:
  - Fuel pump

	<p><b>Fuel pump bolt</b> <b>4 Nm (0.4 m·kg, 2.9 ft·lb)</b></p>
--	--

**NOTE:** \_\_\_\_\_

- Do not damage the installation surface of the fuel tank when installing the fuel pump.
- Always use a new fuel pump gasket.
- Install the fuel pump as shown in the illustration.
- Align the projection "a" on the fuel pump with the slot in the fuel pump bracket.
- Tighten the fuel pump bolts in stages in a crisscross pattern and to the specified torque.

# FUEL TANK

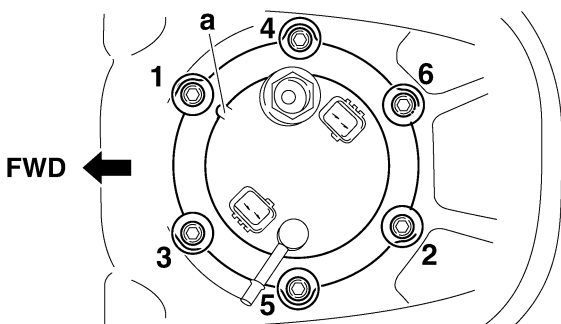

EAS4C81002

## INSTALLING THE FUEL TANK

1. Install:

- Fuel hose
- Fuel hose connector cover

ECA14740

**CAUTION:** \_\_\_\_\_

**When installing the fuel hose, make sure that it is securely connected, and that the fuel hose holders are in the correct position, otherwise the fuel hose will not be properly installed.**

**NOTE:** \_\_\_\_\_

Install the fuel hose connector securely onto the fuel tank until a distinct “click” is heard, and then make sure that it does not come loose. To install the fuel hose from the fuel injection hose, slide the cover “a” on the end of the hose in the direction of arrow shown.

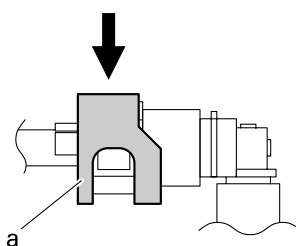

2. Install:

- Fuel sender coupler
- Fuel pump coupler
- Fuel tank breather hose
- Fuel tank drain hose
- Fuel tank side cover

**NOTE:** \_\_\_\_\_

There is white paint mark on the fuel tank breather hose.  
Refer to "CABLE ROUTING" on page 2-39.

# THROTTLE BODIES

EAS26970

## THROTTLE BODIES

### Removing the throttle bodies

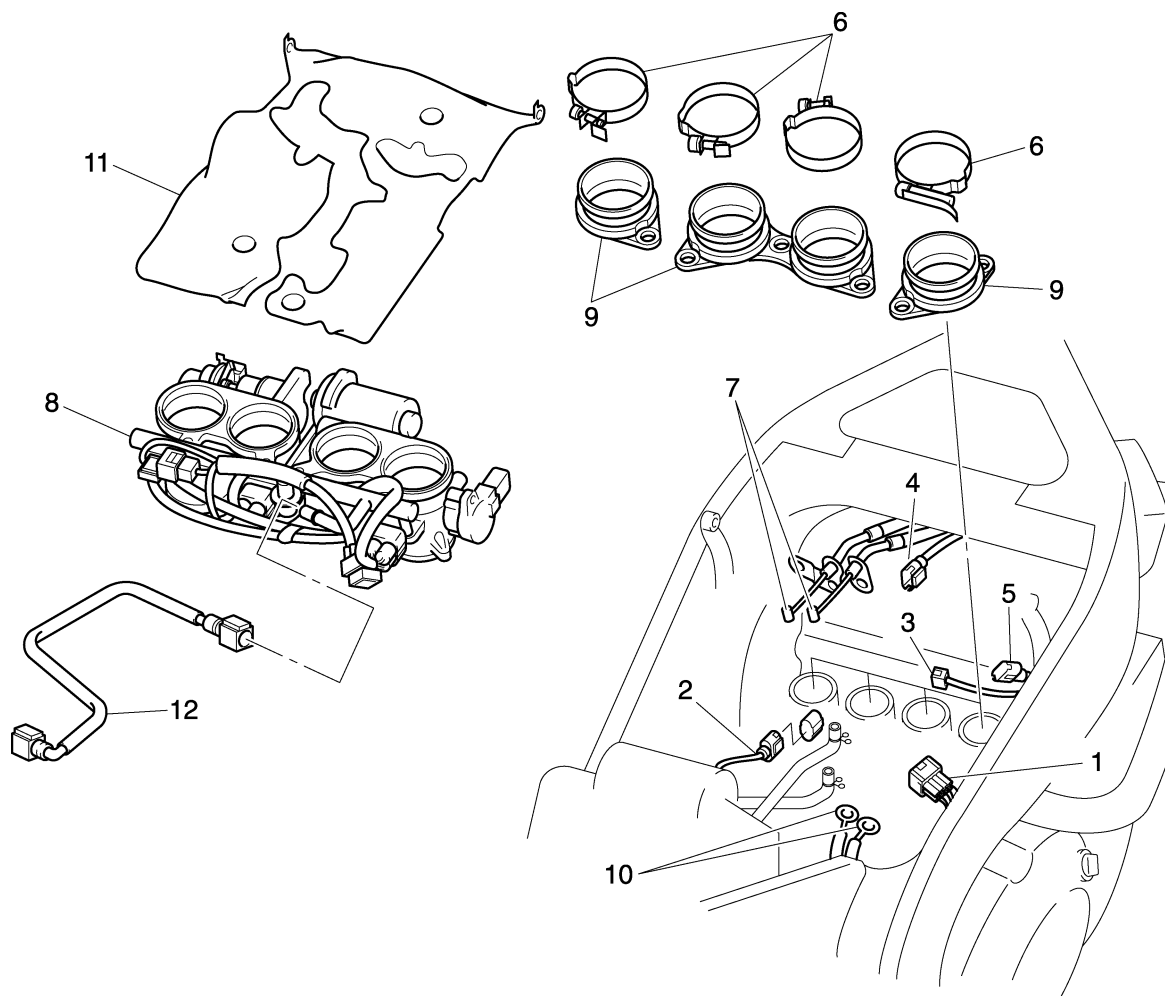

Order	Job/Parts to remove	Q'ty	Remarks
	Rider seat		Refer to "GENERAL CHASSIS" on page 4-1.
	Fuel tank		Refer to "FUEL TANK" on page 7-1.
	Air filter case		Refer to "GENERAL CHASSIS" on page 4-1.
1	Sub-wire harness coupler	1	Disconnect.
2	Coolant temperature sensor coupler	1	Disconnect.
3	Throttle servo motor coupler	1	Disconnect.
4	Throttle position sensor (for throttle valves) coupler	1	Disconnect.
5	Throttle position sensor (for throttle cable pulley) coupler	1	Disconnect.
6	Throttle body joint clamp	4	Loosen.
7	Throttle cables	2	Disconnect.
8	Throttle bodies	1	
9	Throttle body joint	3	
10	Engine ground	2	
11	Heat protector	1	
12	Fuel hose	1	
			For installation, reverse the removal procedure.

## THROTTLE BODIES

### Removing the injectors

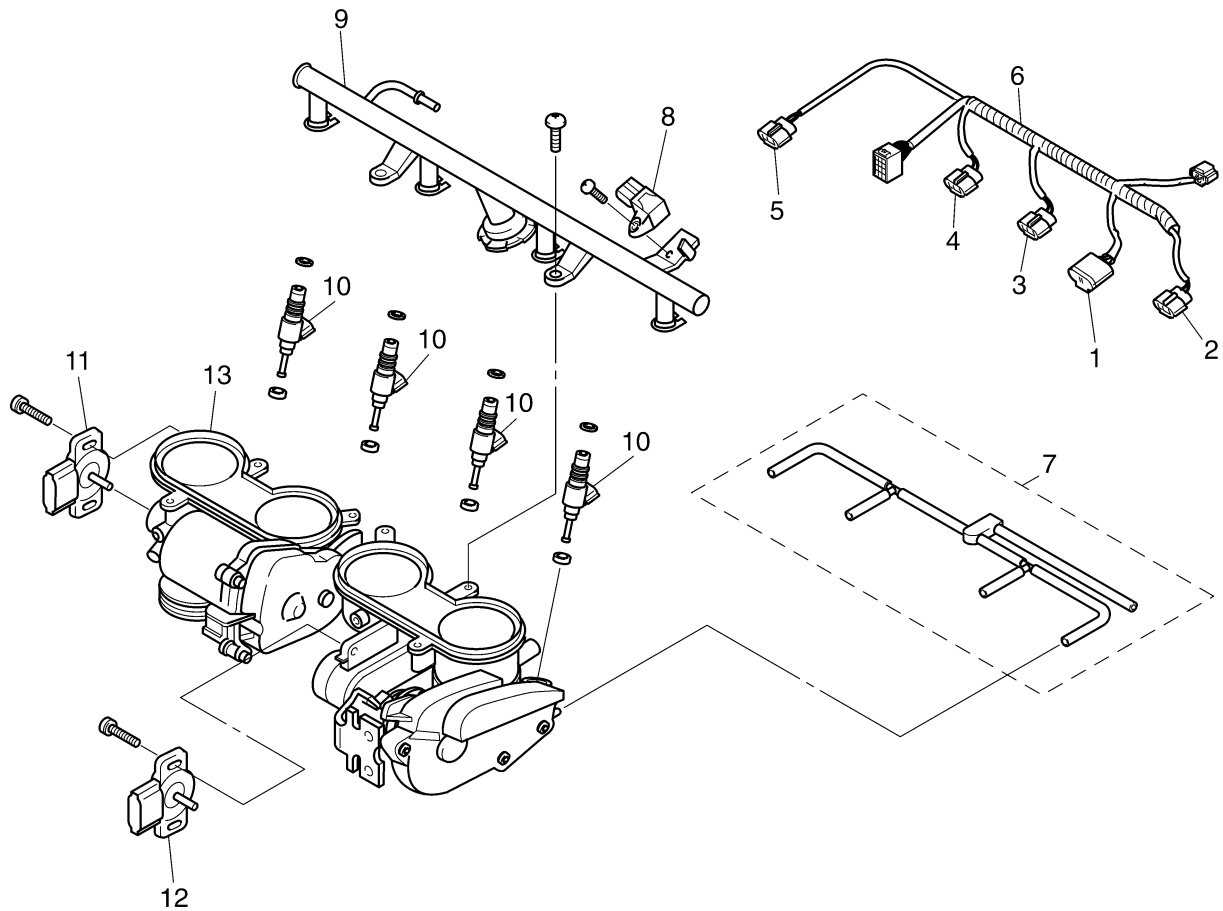

Order	Job/Parts to remove	Q'ty	Remarks
1	Intake air pressure sensor coupler	1	Disconnect.
2	Cylinder #1-injector coupler	1	Disconnect.
3	Cylinder #2-injector coupler	1	Disconnect.
4	Cylinder #3-injector coupler	1	Disconnect.
5	Cylinder #4-injector coupler	1	Disconnect.
6	Sub-wire harness	1	
7	Negative pressure hose	1	Disconnect.
8	Intake air pressure sensor	1	
9	Fuel distributor	1	
10	Injector	4	
11	Throttle position sensor (for throttle valves)	1	
12	Throttle position sensor (for throttle cable pulley)	1	
13	Throttle body assembly	1	
			For installation, reverse the removal procedure.

## THROTTLE BODIES

EAS26980

### CHECKING THE INJECTORS

1. Check:
  - Injectors  
Damage → Replace.

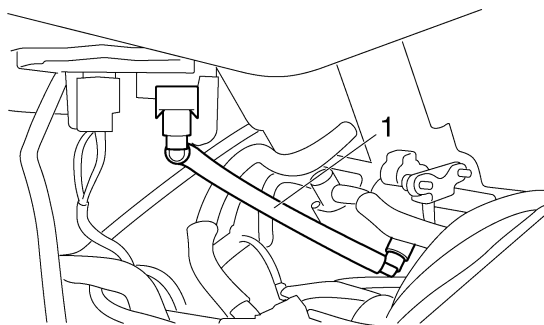
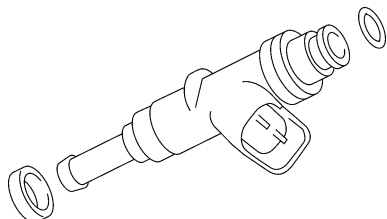

- c. Connect the pressure gauge "2" and adapter "3" to the fuel hose (fuel tank to primary injector fuel rail).

**Pressure gauge**  
**90890-03153**  
**YU-03153**  
**Fuel pressure adapter**  
**90890-03176**  
**YM-03176**

EAS26990

### CHECKING THE THROTTLE BODIES

1. Check:
  - Throttle bodies  
Cracks/damage → Replace the throttle bodies as a set.
2. Check:
  - Fuel passages  
Obstructions → Clean.



- a. Wash the throttle bodies in a petroleum-based solvent.  
Do not use any caustic carburetor cleaning solution.
- b. Blow out all of the passages with compressed air.

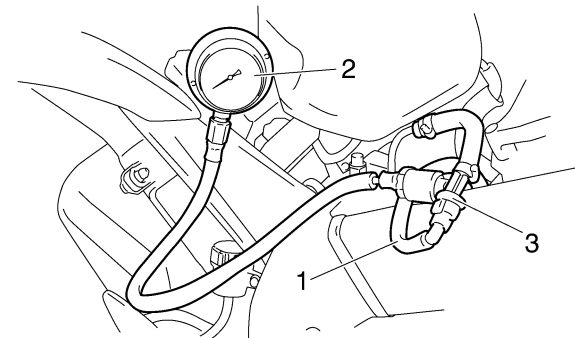

EAS4S81001

### CHECKING THE FUEL PRESSURE

1. Check:
  - Fuel pressure



- a. Remove the rider and passenger seat.  
Refer to "GENERAL CHASSIS" on page 4-1.
- b. Disconnect the fuel hose (fuel tank to primary injector fuel rail) "1" from the primary injector fuel rail.

EWA4C81001



**Cover fuel hose connections with a cloth when disconnecting them. Residual pressure in the fuel lines could cause fuel to spurt out when removing the hoses.**

- d. Start the engine.
- e. Measure the fuel pressure.

**Fuel pressure**  
**324 kPa (46.1 psi) (3.24 kg/cm<sup>2</sup>)**

Faulty → Replace fuel pump.



EAS27030

### ADJUSTING THE THROTTLE POSITION SENSOR (FOR THROTTLE VALVES)

1. Check:
  - Throttle position sensor (for throttle valves)  
Refer to "CHECKING THE THROTTLE POSITION SENSOR (FOR THROTTLE VALVES)" on page 8-101.
2. Adjust:
  - Throttle position sensor angle



## THROTTLE BODIES

---

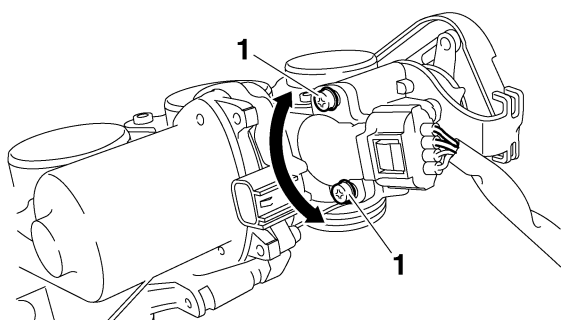

# AIR INDUCTION SYSTEM

EAS27040

## AIR INDUCTION SYSTEM

### Removing the air cut-off valve assembly and hoses

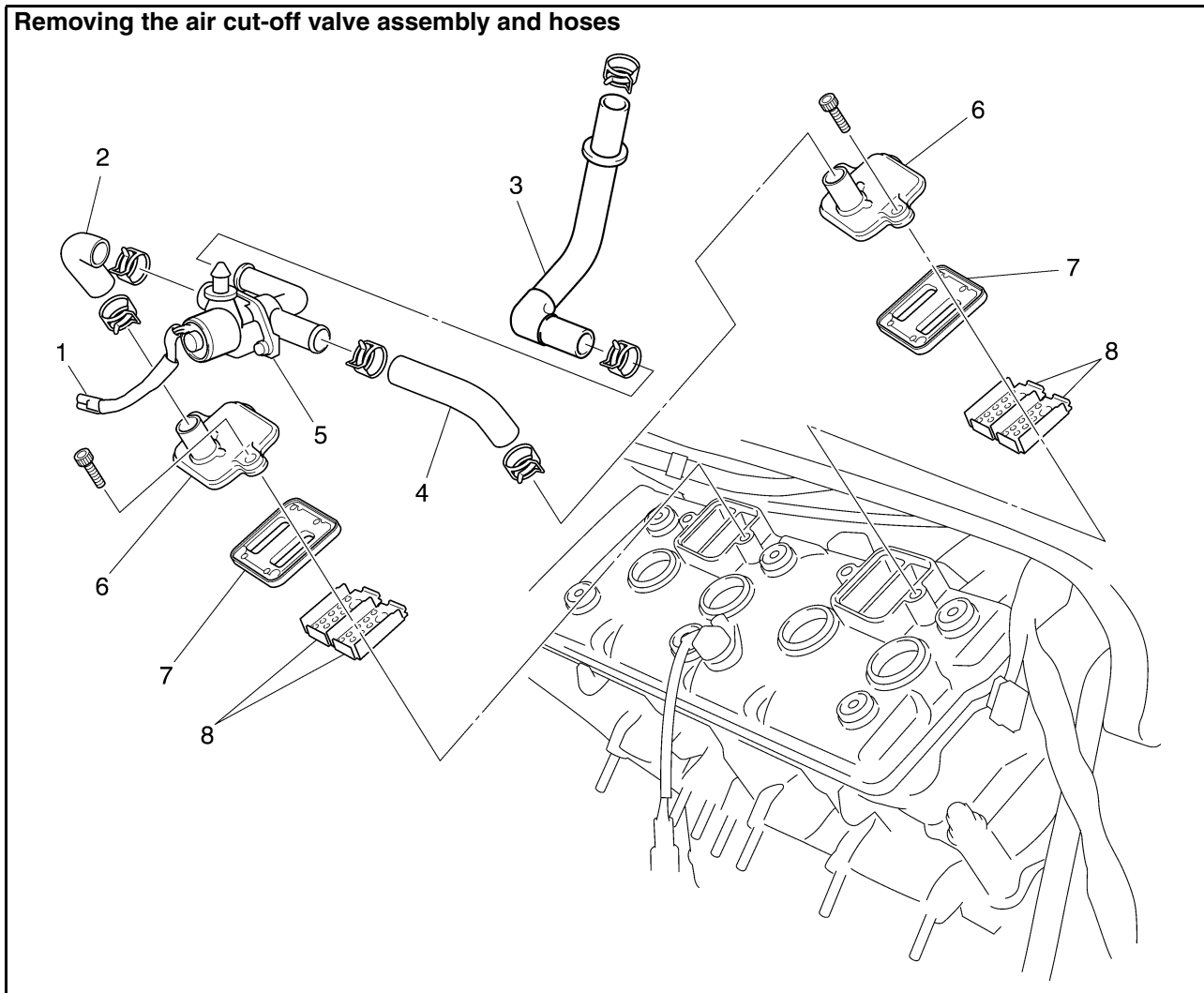

Order	Job/Parts to remove	Q'ty	Remarks
1	Air cut-off valve coupler	1	Disconnect.
2	Air cut-off valve hose 1	1	Disconnect.
3	Air cut-off valve hose 2	1	Disconnect.
4	Air cut-off valve hose 3	1	Disconnect.
5	Air cut-off valve	1	
6	Reed valve cap	2	
7	Reed valve assembly	2	
8	Plate	4	
			For installation, reverse the removal procedure.

## AIR INDUCTION SYSTEM

EAS27060

### CHECKING THE AIR INDUCTION SYSTEM

#### Air injection

The air induction system burns unburned exhaust gases by injecting fresh air (secondary air) into the exhaust port, reducing the emission of hydrocarbons. When there is negative pressure at the exhaust port, the reed valve opens, allowing secondary air to flow into the exhaust port. The required temperature for burning the unburned exhaust gases is approximately 600 to 700°C.

#### Air cut-off valve

The air cut-off valve is controlled by the signals from the ECU in accordance with the combustion conditions. Ordinarily, the air cut-off valve opens to allow the air to flow during idle and closes to cut-off the flow when the vehicle is being driven. However, if the coolant temperature is below the specified value, the air cut-off valve remains open and allows the air to flow into the exhaust pipe until the temperature becomes higher than the specified value.

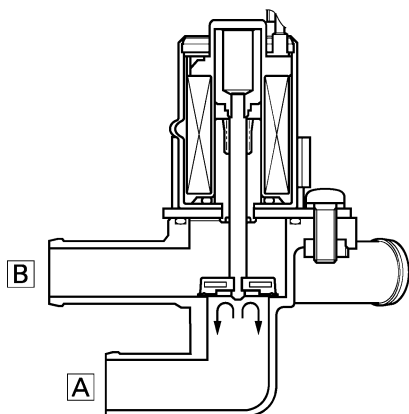
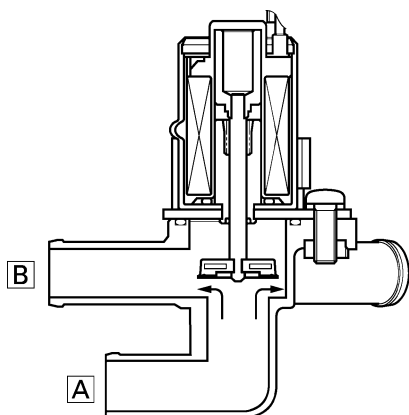

- A. From the air cleaner
  - B. To the cylinder head
1. Check:
    - Hoses  
Loose connections → Connect properly.  
Cracks/damage → Replace.
    - Pipes  
Cracks/damage → Replace.
  2. Check:
    - Reed valve "1"
    - Reed valve stopper
    - Reed valve seat  
Cracks/damage → Replace the reed valve.

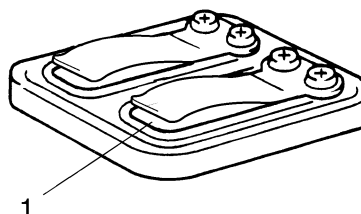

3. Measure:
  - Reed valve bending limit "a"  
Out of specification → Replace the reed valve.

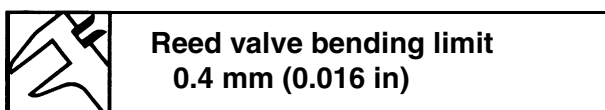

**Reed valve bending limit**  
**0.4 mm (0.016 in)**

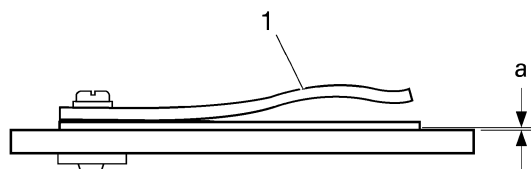

14710301

4. Check:
  - Air cut-off valve  
Cracks/damage → Replace.
5. Check
  - Air induction system solenoid  
Refer to "CHECKING THE AIR INDUCTION SYSTEM SOLENOID" on page 8-102.

## **AIR INDUCTION SYSTEM**

---

---

## ELECTRICAL SYSTEM

<b>IGNITION SYSTEM</b> .....	8-1
CIRCUIT DIAGRAM.....	8-1
TROUBLESHOOTING.....	8-3
<b>ELECTRIC STARTING SYSTEM</b> .....	8-5
CIRCUIT DIAGRAM.....	8-5
STARTING CIRCUIT CUT-OFF SYSTEM OPERATION.....	8-7
TROUBLESHOOTING.....	8-9
<b>CHARGING SYSTEM</b> .....	8-11
CIRCUIT DIAGRAM.....	8-11
TROUBLESHOOTING.....	8-13
<b>LIGHTING SYSTEM</b> .....	8-15
CIRCUIT DIAGRAM.....	8-15
TROUBLESHOOTING.....	8-17
<b>SIGNALING SYSTEM</b> .....	8-19
CIRCUIT DIAGRAM.....	8-19
TROUBLESHOOTING.....	8-21
<b>COOLING SYSTEM</b> .....	8-25
CIRCUIT DIAGRAM.....	8-25
TROUBLESHOOTING.....	8-27
<b>FUEL INJECTION SYSTEM</b> .....	8-29
CIRCUIT DIAGRAM.....	8-29
ECU SELF-DIAGNOSTIC FUNCTION.....	8-31
FAIL-SAFE ACTIONS (SUBSTITUTE CHARACTERISTICS OPERATION CONTROL).....	8-33
TROUBLESHOOTING METHOD.....	8-36
DIAGNOSTIC MODE.....	8-37
TROUBLESHOOTING DETAILS.....	8-45
<b>FUEL PUMP SYSTEM</b> .....	8-67
CIRCUIT DIAGRAM.....	8-67
TROUBLESHOOTING.....	8-69
<b>IMMOBILIZER SYSTEM</b> .....	8-71
CIRCUIT DIAGRAM.....	8-71
GENERAL INFORMATION.....	8-73
PART REPLACEMENT AND KEY CODE REGISTRATION REQUIREMENTS.....	8-74
TROUBLESHOOTING.....	8-77
SELF-DIAGNOSIS FAULT CODE INDICATION.....	8-78

<b>ELECTRICAL COMPONENTS</b> .....	8-81
CHECKING THE SWITCHES.....	8-85
CHECKING THE BULBS AND BULB SOCKETS.....	8-88
CHECKING THE FUSES.....	8-89
CHECKING AND CHARGING THE BATTERY.....	8-89
CHECKING THE RELAYS.....	8-92
CHECKING THE TURN SIGNAL/HAZARD RELAY .....	8-93
CHECKING THE RELAY UNIT (DIODE) .....	8-94
CHECKING THE IGNITION COILS.....	8-95
CHECKING THE CRANKSHAFT POSITION SENSOR.....	8-96
CHECKING THE LEAN ANGLE SENSOR.....	8-96
CHECKING THE STARTER MOTOR OPERATION.....	8-97
CHECKING THE STATOR COIL.....	8-97
CHECKING THE RECTIFIER/REGULATOR.....	8-97
CHECKING THE HORN .....	8-98
CHECKING THE OIL LEVEL SWITCH .....	8-98
CHECKING THE FUEL SENDER .....	8-99
CHECKING THE SPEED SENSOR .....	8-99
CHECKING THE RADIATOR FAN MOTORS .....	8-100
CHECKING THE COOLANT TEMPERATURE SENSOR .....	8-100
CHECKING THE THROTTLE POSITION SENSOR (FOR THROTTLE CABLE PULLEY).....	8-101
CHECKING THE THROTTLE POSITION SENSOR (FOR THROTTLE VALVES).....	8-101
CHECKING THE AIR INDUCTION SYSTEM SOLENOID .....	8-102
CHECKING THE ATMOSPHERIC PRESSURE SENSOR.....	8-102
CHECKING THE CYLINDER IDENTIFICATION SENSOR .....	8-102
CHECKING THE INTAKE AIR PRESSURE SENSOR .....	8-103
CHECKING THE INTAKE AIR TEMPERATURE SENSOR .....	8-103



# IGNITION SYSTEM

EAS27090

## IGNITION SYSTEM

EAS27110

## CIRCUIT DIAGRAM

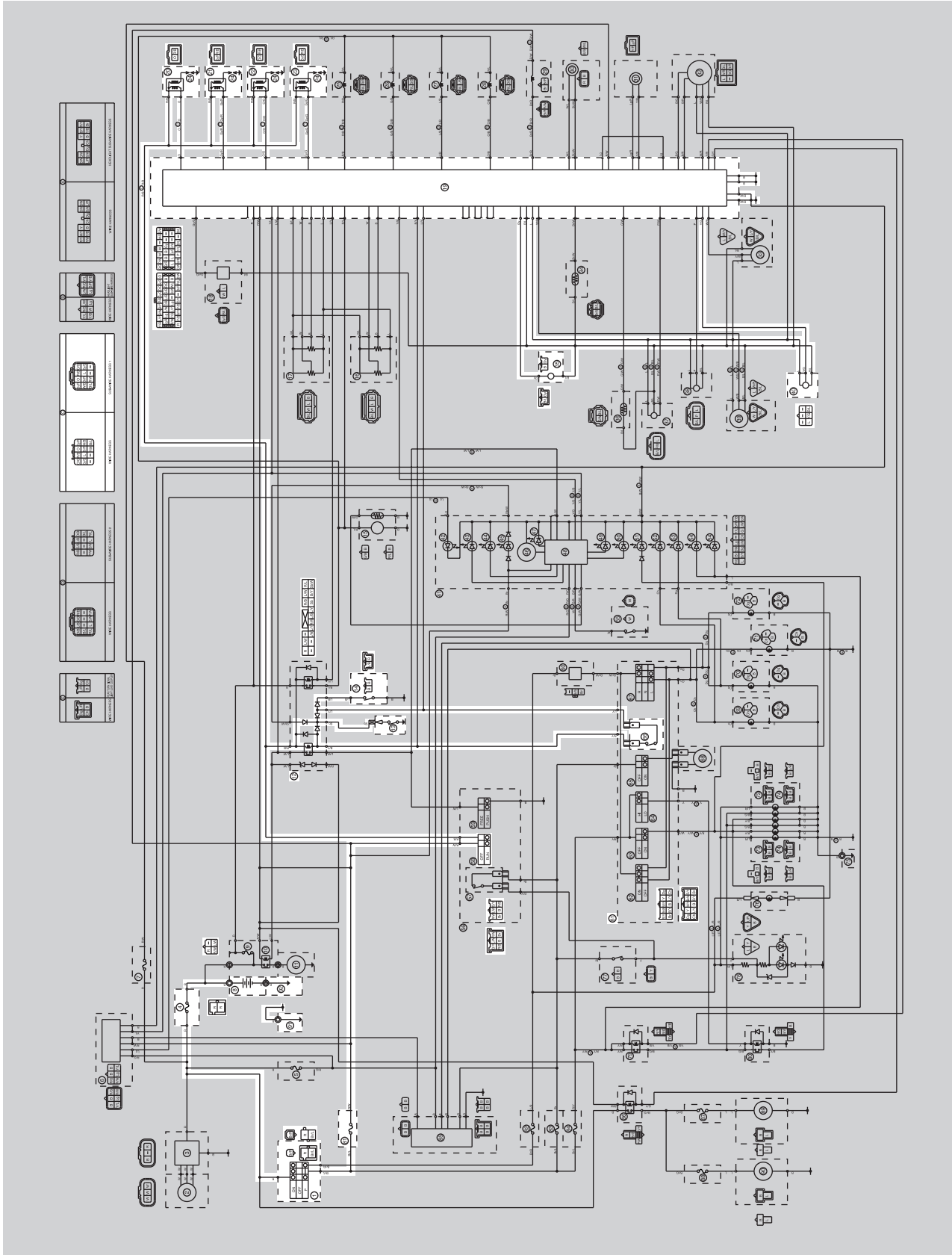

## IGNITION SYSTEM

---

- 1. Main switch
- 4. Main fuse
- 8. Battery
- 12. Starting circuit cut-off relay
- 13. Neutral switch
- 14. Sidestand switch
- 19. ECU (engine control unit)
- 20. Ignition coil #1
- 21. Ignition coil #2
- 22. Ignition coil #3
- 23. Ignition coil #4
- 24. Spark plug
- 35. Crankshaft position sensor
- 40. Lean angle sensor
- 58. Engine stop switch
- 66. Clutch switch
- 81. Ignition fuse
- 91. Ground
- 92. Battery negative lead

## IGNITION SYSTEM

EAS27150

### TROUBLESHOOTING

The ignition system fails to operate (no spark or intermittent spark).

**NOTE:**

- Before troubleshooting, remove the following part(s):

- 1 Rider seat
- 2 Passenger seat
- 3 Fuel tank
- 4 Side cowlings

1 Check the fuses. (Main and ignition) Refer to "CHECKING THE FUSES" on page 8-89.	NG→	Replace the fuse(s).
OK↓		
2 Check the battery. Refer to "CHECKING AND CHARGING THE BATTERY" on page 8-89.	NG→	<ul style="list-style-type: none"> <li>• Clean the battery terminals.</li> <li>• Recharge or replace the battery.</li> </ul>
OK↓		
3 Check the spark plugs. Refer to "CHECKING THE SPARK PLUGS" on page 3-10.	NG→	Re-gap or replace the spark plugs.
OK↓		
4 Check the ignition spark gap. Refer to "CHECKING THE IGNI- TION COILS" on page 8-95.	NG→	Ignition system is OK.
OK↓		
5 Check the ignition coils. Refer to "CHECKING THE IGNI- TION COILS" on page 8-95.	NG→	Replace the ignition coils.
OK↓		
6 Check the crankshaft position sen- sor. Refer to "CHECKING THE CRANKSHAFT POSITION SEN- SOR" on page 8-96.	NG→	Replace the crankshaft position sen- sor.
OK↓		
7 Check the main switch. Refer to "CHECKING THE SWITCHES" on page 8-85.	NG→	Replace the main switch/immobilizer unit assembly.
OK↓		

## IGNITION SYSTEM

8 Check the engine stop switch. Refer to "CHECKING THE SWITCHES" on page 8-85.	NG→	Replace the right handlebar switch.
OK↓		
9 Check the neutral switch. Refer to "CHECKING THE SWITCHES" on page 8-85.	NG→	Replace the neutral switch.
OK↓		
10 Check the sidestand switch. Refer to "CHECKING THE SWITCHES" on page 8-85.	NG→	Replace the sidestand switch.
OK↓		
11 Check the clutch switch. Refer to "CHECKING THE SWITCHES" on page 8-85.	NG→	Replace the clutch switch.
OK↓		
12 Check the starting circuit cut-off relay. Refer to "CHECKING THE RELAYS" on page 8-92.	NG→	Replace the starting circuit cut-off relay.
OK↓		
13 Check the lean angle sensor. Refer to "CHECKING THE LEAN ANGLE SENSOR" on page 8-96.	NG→	Replace the lean angle sensor.
OK↓		
14 Check the entire ignition system's wiring. Refer to "CIRCUIT DIAGRAM" on page 8-1.	NG→	Properly connect or repair the ignition system's wiring
OK↓		
Replace the ECU.		

# ELECTRIC STARTING SYSTEM

## EAS27160 ELECTRIC STARTING SYSTEM

## EAS27170 CIRCUIT DIAGRAM

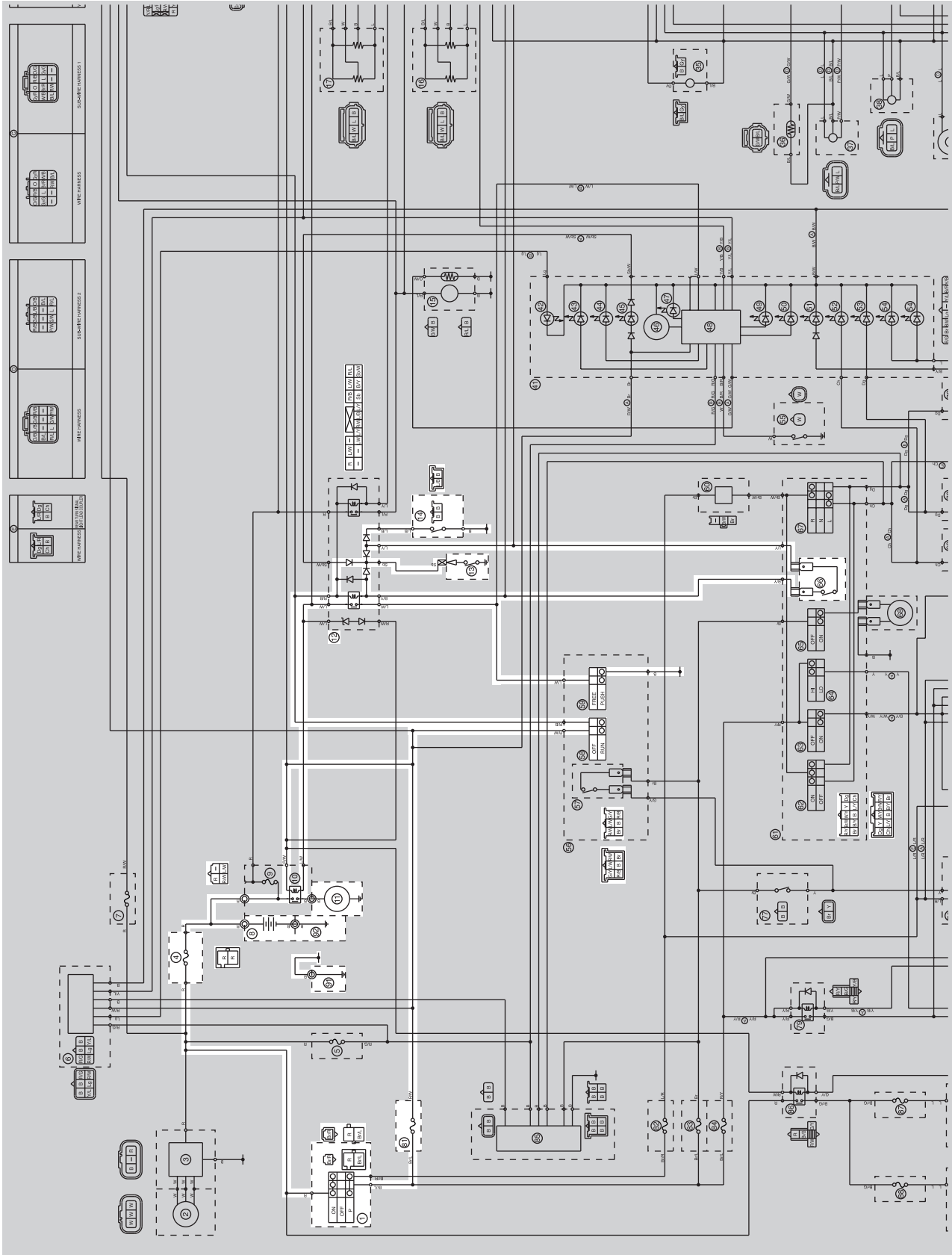

## **ELECTRIC STARTING SYSTEM**

---

- 1. Main switch
- 4. Main fuse
- 8. Battery
- 10. Starter relay
- 11. Starter motor
- 12. Starting circuit cut-off relay
- 13. Neutral switch
- 14. Sidestand switch
- 58. Engine stop switch
- 59. Start switch
- 66. Clutch switch
- 81. Ignition fuse
- 91. Ground
- 92. Battery negative lead

## ELECTRIC STARTING SYSTEM

EAS27180

### STARTING CIRCUIT CUT-OFF SYSTEM OPERATION

If the engine stop switch is set to “○” and the main switch is set to “ON” (both switches are closed), the starter motor can only operate if at least one of the following conditions is met:

- The transmission is in neutral (the neutral switch is closed).
- The clutch lever is pulled to the handlebar (the clutch switch is closed) and the sidestand is up (the sidestand switch is closed).

The starting circuit cut-off relay prevents the starter motor from operating when neither of these conditions has been met. In this instance, the starting circuit cut-off relay is open so current cannot reach the starter motor. When at least one of the above conditions has been met the starting circuit cut-off relay is closed and the engine can be started by pressing the starter switch.

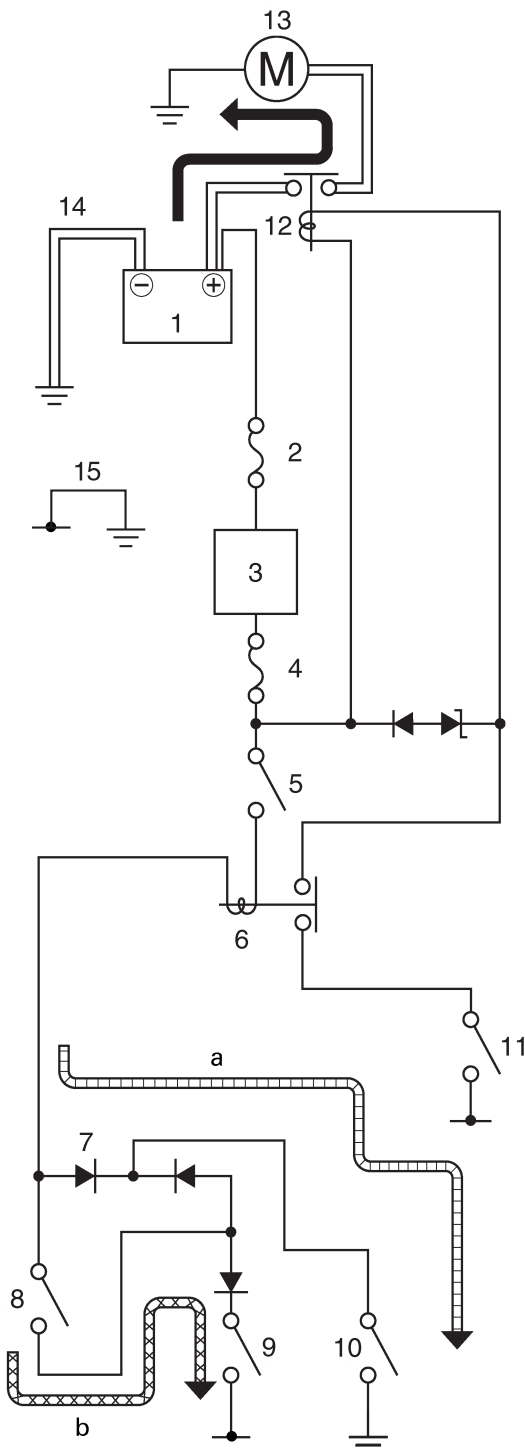

## ELECTRIC STARTING SYSTEM

---

- a. WHEN THE TRANSMISSION IS IN NEUTRAL
- b. WHEN THE SIDESTAND IS UP AND THE CLUTCH LEVER IS PULLED TO THE HANDLEBAR
  1. Battery
  2. Main fuse
  3. Main switch
  4. Ignition fuse
  5. Engine stop switch
  6. Starting circuit cut-off relay
  7. Diode
  8. Clutch switch
  9. Sidestand switch
  10. Neutral switch
  11. Start switch
  12. Starter relay
  13. Starter motor
  14. Battery negative lead
  15. Ground

## ELECTRIC STARTING SYSTEM

EAS27190

### TROUBLESHOOTING

The starter motor fails to turn.

**NOTE:**

- Before troubleshooting, remove the following part(s):

- 1 Rider seat
- 2 Passenger seat
- 3 Fuel tank
- 4 Air filter case

<p>1 Check the fuses. (Main and ignition) Refer to "CHECKING THE FUSES" on page 8-89.</p>	NG→	<p>Replace the fuse(s).</p>
OK↓		
<p>2 Check the battery. Refer to "CHECKING AND CHARGING THE BATTERY" on page 8-89.</p>	NG→	<ul style="list-style-type: none"> <li>• Clean the battery terminals.</li> <li>• Recharge or replace the battery.</li> </ul>
OK↓		
<p>3 Check the starter motor operation. Refer to "CHECKING THE STARTER MOTOR OPERATION" on page 8-97.</p>	NG→	<p>Repair or replace the starter motor.</p>
OK↓		
<p>4 Check the starter motor. Refer to "CHECKING THE STARTER MOTOR" on page 5-41.</p>	NG→	<p>Repair or replace the starter motor.</p>
OK↓		
<p>5 Check the starting circuit cut-off relay. Refer to "CHECKING THE RELAYS" on page 8-92.</p>	NG→	<p>Replace the starting circuit cut-off relay.</p>
OK↓		
<p>6 Check the starter relay. Refer to "CHECKING THE RELAYS" on page 8-92.</p>	NG→	<p>Replace the starter relay.</p>
OK↓		
<p>7 Check the main switch. Refer to "CHECKING THE SWITCHES" on page 8-85.</p>	NG→	<p>Replace the main switch/immobilizer assembly.</p>
OK↓		

## ELECTRIC STARTING SYSTEM

---

8 Check the engine stop switch. Refer to "CHECKING THE SWITCHES" on page 8-85.	NG→	Replace the right handlebar switch.
OK↓		
9 Check the neutral switch. Refer to "CHECKING THE SWITCHES" on page 8-85.	NG→	Replace the neutral switch.
OK↓		
10 Check the sidestand switch. Refer to "CHECKING THE SWITCHES" on page 8-85.	NG→	Replace the sidestand switch.
OK↓		
11 Check the clutch switch. Refer to "CHECKING THE SWITCHES" on page 8-85.	NG→	Replace the clutch switch.
OK↓		
12 Check the start switch. Refer to "CHECKING THE SWITCHES" on page 8-85.	NG→	Replace the right handlebar switch.
OK↓		
13 Check the entire starting system's wiring. Refer to "ELECTRIC STARTING SYSTEM" on page 8-5.	NG→	Properly connect or repair the starting system's wiring
OK↓		
The starting system circuit is OK.		

# CHARGING SYSTEM

EAS27200

## CHARGING SYSTEM

EAS27210

## CIRCUIT DIAGRAM

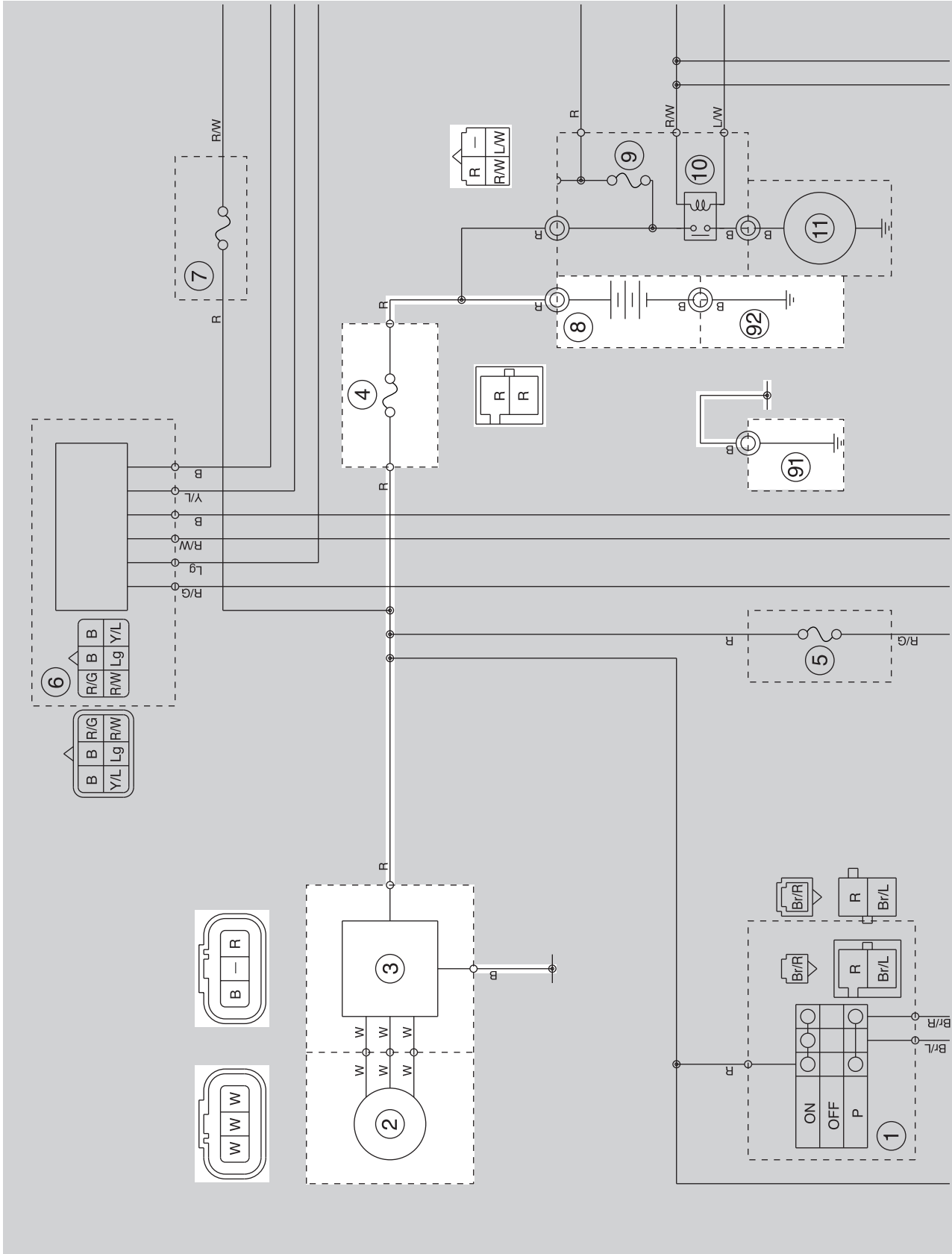

## CHARGING SYSTEM

---

- 2. AC magneto
- 3. Rectifier/regulator
- 4. Main fuse
- 8. Battery
- 91. Ground
- 92. Battery negative lead

## CHARGING SYSTEM

EAS27230

### TROUBLESHOOTING

The battery is not being charged.

**NOTE:**

- Before troubleshooting, remove the following part(s):

- 1 Rider seat
- 2 Fuel tank
- 3 Air filter case

1 Check the fuse. (Main) Refer to "CHECKING THE FUSES" on page 8-89.	NG→	Replace the fuse.
OK↓		
2 Check the battery. Refer to "CHECKING AND CHARGING THE BATTERY" on page 8-89.	NG→	<ul style="list-style-type: none"> <li>• Clean the battery terminals.</li> <li>• Recharge or replace the battery.</li> </ul>
OK↓		
3 Check the stator coil Refer to "CHECKING THE STATOR COIL" on page 8-97.	NG→	<ul style="list-style-type: none"> <li>• Replace the stator coil assembly.</li> </ul>
OK↓		
4 Check the rectifier/regulator. Refer to "CHECKING THE RECTI- FIER/REGULATOR" on page 8-97.	NG→	Replace the rectifier/regulator.
OK↓		
5 Check the entire charging system's wiring. Refer to "CHARGING SYSTEM" on page 8-11.	NG→	Properly connect or repair the charg- ing system's wiring.
OK↓		
This circuit is OK.		

## **CHARGING SYSTEM**

---

# LIGHTING SYSTEM

EAS27240

## LIGHTING SYSTEM

EAS27250

## CIRCUIT DIAGRAM

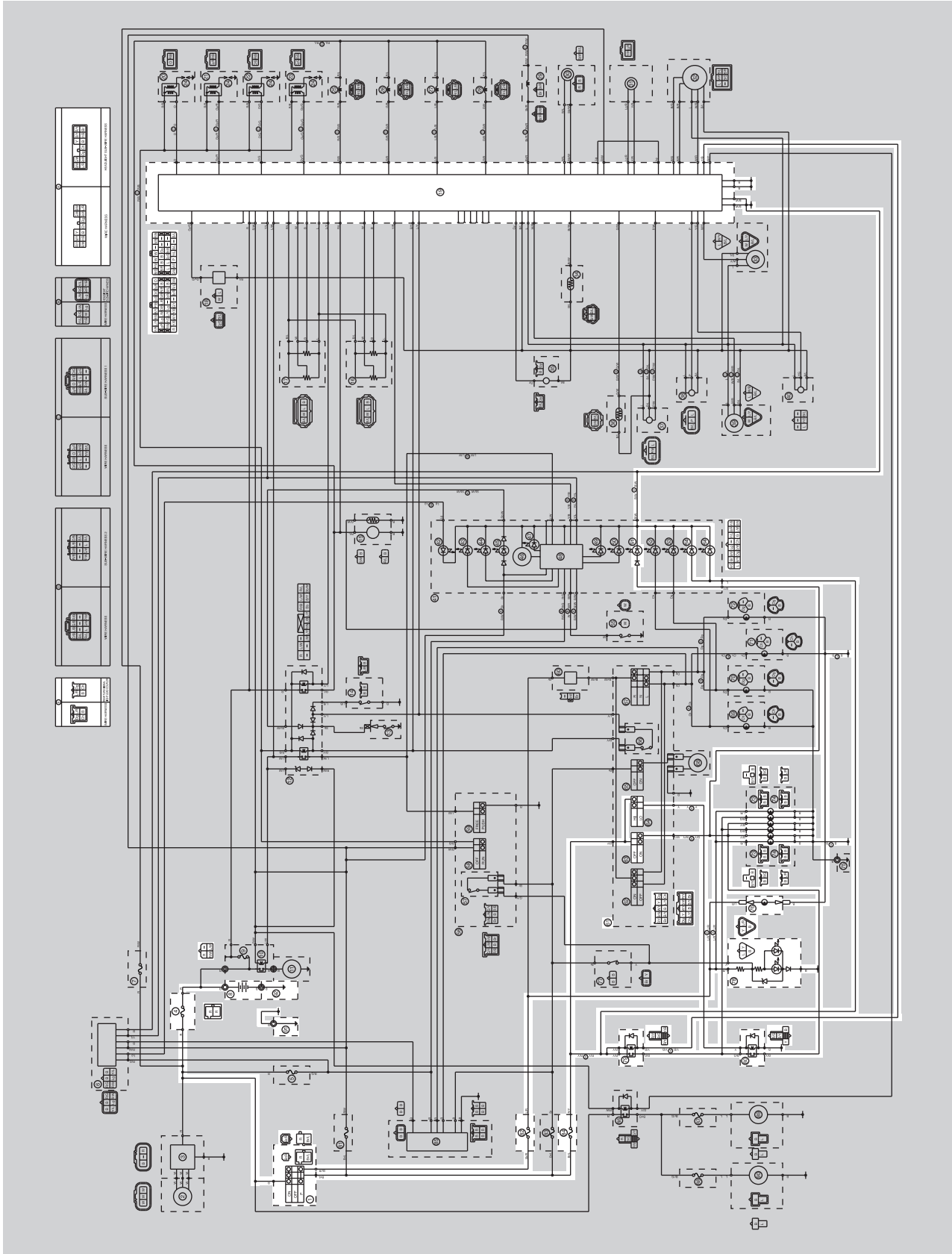

## LIGHTING SYSTEM

---

- 1. Main switch
- 4. Main fuse
- 8. Battery
- 19. ECU (engine control unit)
- 51. High beam indicator light
- 54. Meter light
- 63. Pass switch
- 64. Dimmer switch
- 73. Headlight
- 74. Auxiliary light
- 76. License plate light
- 78. Tail/brake light
- 79. Headlight relay (on/off)
- 80. Headlight relay (dimmer)
- 82. Turn signal light fuse
- 84. Headlight fuse
- 91. Ground
- 92. Battery negative lead

## LIGHTING SYSTEM

EAS27260

### TROUBLESHOOTING

Any of the following fail to light: headlight, high beam indicator light, taillight, license light or meter light.

**NOTE:**

- Before troubleshooting, remove the following part(s):

- 1 Rider seat
- 2 Fuel tank
- 3 Side cowlings

<p>1 Check the each bulbs and bulb sockets condition. Refer to "CHECKING THE BULBS AND BULB SOCKETS" on page 8-88.</p>	NG→	<p>Replace the bulb(s) and bulb socket(s).</p>
OK↓		
<p>2 Check the fuses. (Main, headlight and park) Refer to "CHECKING THE FUSES" on page 8-89.</p>	NG→	<p>Replace the fuse(s).</p>
OK↓		
<p>3 Check the battery. Refer to "CHECKING AND CHARGING THE BATTERY" on page 8-89.</p>	NG→	<ul style="list-style-type: none"> <li>• Clean the battery terminals.</li> <li>• Recharge or replace the battery.</li> </ul>
OK↓		
<p>4 Check the main switch. Refer to "CHECKING THE SWITCHES" on page 8-85.</p>	NG→	<p>Replace the immobilizer unit.</p>
OK↓		
<p>5 Check the dimmer switch. Refer to "CHECKING THE SWITCHES" on page 8-85.</p>	NG→	<p>The dimmer switch is faulty. Replace the left handlebar switch.</p>
OK↓		
<p>6 Check the pass switch. Refer to "CHECKING THE SWITCHES" on page 8-85.</p>	NG→	<p>The pass switch is faulty. Replace the left handlebar switch.</p>
OK↓		
<p>7 Check the rear brake light switch. Refer to "CHECKING THE SWITCHES" on page 8-85.</p>	NG→	<p>Replace the rear brake light switch.</p>
OK↓		

## LIGHTING SYSTEM

8 Check the headlight relay (on/off).  
Refer to "CHECKING THE RELAYS" on page 8-92.

NG→

Replace the headlight relay.

OK↓

9 Check the headlight relay (dimmer).  
Refer to "CHECKING THE RELAYS" on page 8-92.

NG→

Replace the headlight relay.

OK↓

10 Check the entire lighting system's wiring.  
Refer to "LIGHTING SYSTEM" on page 8-15.

NG→

Properly connect or repair the lighting system's wiring.

OK↓

This circuit is OK.

# SIGNALING SYSTEM

EAS27270

## SIGNALING SYSTEM

EAS27280

## CIRCUIT DIAGRAM

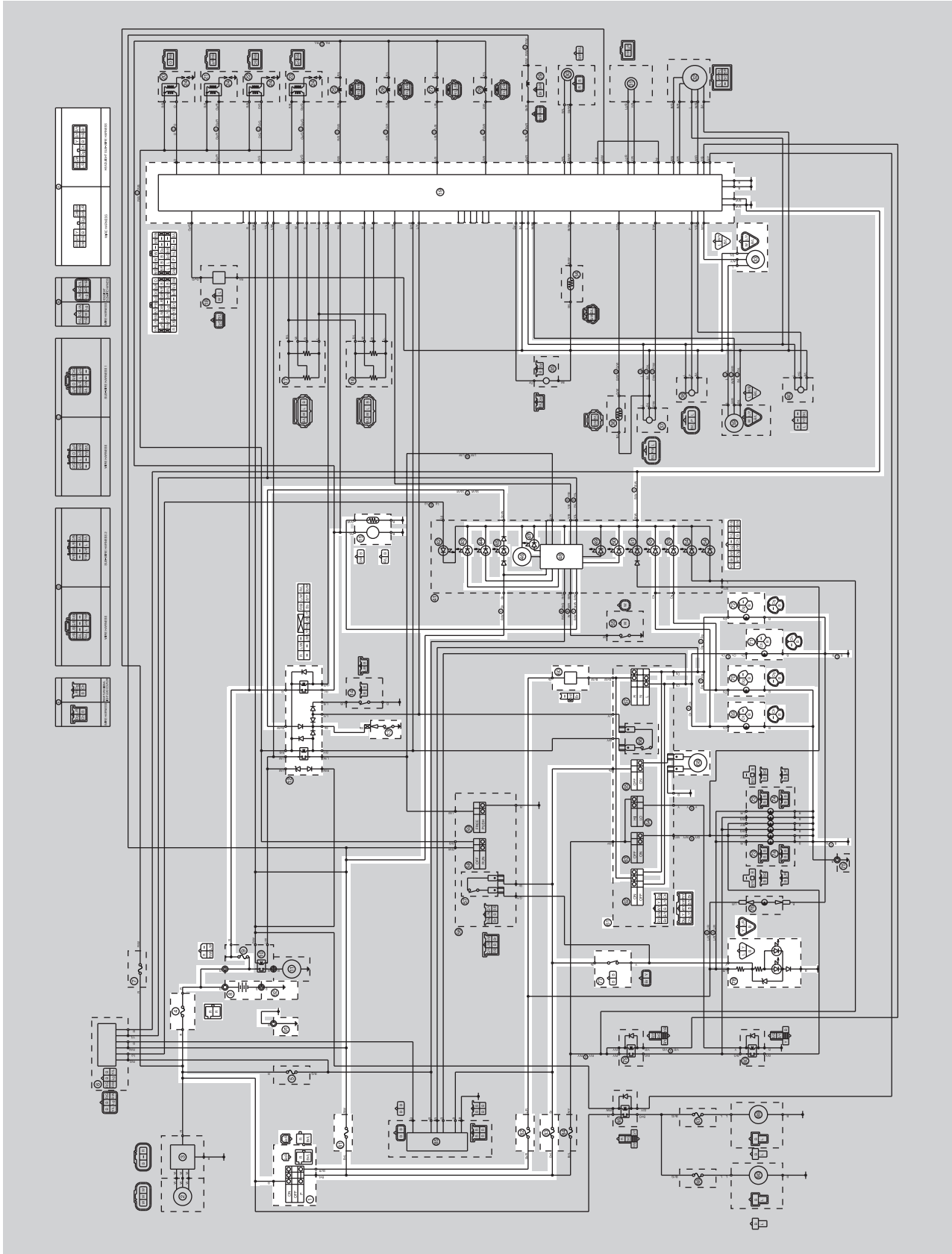

## SIGNALING SYSTEM

---

1. Main switch
4. Main fuse
8. Battery
9. Fuel injection system fuse
12. Starting circuit cut-off relay
13. Neutral switch
15. Fuel pump
19. ECU (engine control unit)
33. Speed sensor
43. Fuel level warning light
44. Oil level warning light
45. Neutral indicator light
46. Tachometer
47. Shift timing indicator light
48. Multi-function meter
50. Coolant temperature indicator light
52. Left turn signal indicator light
53. Right turn signal indicator light
57. Front brake light switch
60. Turn signal/hazard relay
62. Hazard switch
65. Horn switch
67. Turn signal switch
68. Horn
69. Front left turn signal light
70. Front right turn signal light
71. Rear left turn signal light
72. Rear right turn signal light
77. Rear brake light switch
78. Tail/brake light
81. Headlight fuse
82. Turn signal light fuse
83. Signal fuse
91. Ground
92. Battery negative lead

## SIGNALING SYSTEM

EAS27290

### TROUBLESHOOTING

- Any of the following fail to light: turn signal light, brake light or an indicator light.
- The horn fails to sound.

**NOTE:**

- Before troubleshooting, remove the following part(s):

- 1 Rider seat
- 2 Passenger seat
- 3 Fuel tank
- 4 Side cowling

1 Check the fuses. (Main, fuel injection system, head-light, Turn signal light, signal) Refer to "CHECKING THE FUSES" on page 8-89.	NG→	Replace the fuse(s).
OK↓		
2 Check the battery. Refer to "CHECKING AND CHARGING THE BATTERY" on page 8-89.	NG→	<ul style="list-style-type: none"> <li>• Clean the battery terminals.</li> <li>• Recharge or replace the battery.</li> </ul>
OK↓		
3 Check the main switch. Refer to "CHECKING THE SWITCHES" on page 8-85.	NG→	Replace the main switch/immobilizer assembly.
OK↓		
4 Check the entire signaling system's wiring. Refer to "SIGNALING SYSTEM" on page 8-19.	NG→	Properly connect or repair the signaling system's wiring.
OK↓		
This circuit is OK.		

**Check the signaling system**

The horn fails to sound.

1 Check the horn switch. Refer to "CHECKING THE SWITCHES" on page 8-85.	NG→	Replace the left handlebar switch.
OK↓		
2 Check the horn. Refer to "CHECKING THE HORN" on page 8-98.	NG→	Replace the horn.
OK↓		

## SIGNALING SYSTEM

<p>3 Check the entire signaling system's wiring. Refer to "SIGNALING SYSTEM" on page 8-19.</p>	<p>NG→</p>	<p>Properly connect or repair the signaling system's wiring.</p>
<p>OK↓</p>		
<p>This circuit is OK.</p>		
<p><u>The tail/brake light fails to come on.</u></p>		
<p>1 Check the tail/brake light bulb and socket. Refer to "CHECKING THE BULBS AND BULB SOCKETS" on page 8-88.</p>	<p>NG→</p>	<p>Replace the tail/brake light bulb, socket or both.</p>
<p>OK↓</p>		
<p>2 Check the front brake light switch. Refer to "CHECKING THE SWITCHES" on page 8-85.</p>	<p>NG→</p>	<p>Replace the front brake light switch.</p>
<p>OK↓</p>		
<p>3 Check the rear brake light switch. Refer to "CHECKING THE SWITCHES" on page 8-85.</p>	<p>NG→</p>	<p>Replace the rear brake light switch.</p>
<p>OK↓</p>		
<p>4 Check the entire signaling system's wiring. Refer to "SIGNALING SYSTEM" on page 8-19.</p>	<p>NG→</p>	<p>Properly connect or repair the signaling system's wiring.</p>
<p>OK↓</p>		
<p>This circuit is OK.</p>		
<p><u>The turn signal light, turn signal indicator light or both fail to blink.</u></p>		
<p>1 Check the turn signal light bulb and socket. Refer to "CHECKING THE BULBS AND BULB SOCKETS" on page 8-88.</p>	<p>NG→</p>	<p>Replace the turn signal indicator light bulb, socket or both.</p>
<p>OK↓</p>		
<p>2 Check the turn signal switch. Refer to "CHECKING THE SWITCHES" on page 8-85.</p>	<p>NG→</p>	<p>Replace the left handlebar switch.</p>
<p>OK↓</p>		

## SIGNALING SYSTEM

3 Check the hazard switch.  
Refer to "CHECKING THE SWITCHES" on page 8-85.

NG→

Replace the left handlebar switch.

OK↓

4 Check the turn signal relay.  
Refer to "CHECKING THE RELAYS" on page 8-92.

NG→

The turn signal relay is faulty and must be replaced.

OK↓

5 Check the entire signaling system's wiring.  
Refer to "SIGNALING SYSTEM" on page 8-19.

NG→

Properly connect or repair the signaling system's wiring.

OK↓

This circuit is OK.

The neutral indicator light fails to come on.

1 Check the neutral switch.  
Refer to "CHECKING THE SWITCHES" on page 8-85.

NG→

Replace the neutral switch.

OK↓

2 Check the entire signaling system's wiring.  
Refer to "SIGNALING SYSTEM" on page 8-19.

NG→

Properly connect or repair the signaling system's wiring.

OK↓

This circuit is OK.

The oil level warning light fails to come on.

1 Check the oil level switch.  
Refer to "CHECKING THE SWITCHES" on page 8-85.

NG→

Replace the oil level switch.

OK↓

## SIGNALING SYSTEM

2 Check the entire signaling system's wiring.  
Refer to "SIGNALING SYSTEM" on page 8-19.

NG→

Properly connect or repair the signaling system's wiring.

OK↓

This circuit is OK.

The fuel level warning light fails to come on.

1 Check the fuel sender.  
Refer to "CHECKING THE FUEL SENDER" on page 8-99.

NG→

Replace the fuel pump assembly.

OK↓

2 Check the entire signaling system's wiring.  
Refer to "SIGNALING SYSTEM" on page 8-19.

NG→

Properly connect or repair the signaling system's wiring.

OK↓

This circuit is OK.

The speedometer fails to operate.

1 Check the speed sensor.  
Refer to "CHECKING THE SPEED SENSOR" on page 8-99.

NG→

Replace the speed sensor.

OK↓

2 Check the entire signaling system's wiring.  
Refer to "SIGNALING SYSTEM" on page 8-19.

NG→

Properly connect or repair the signaling system's wiring.

OK↓

Replace the meter assembly.

# COOLING SYSTEM

EAS27300

## COOLING SYSTEM

EAS27310

## CIRCUIT DIAGRAM

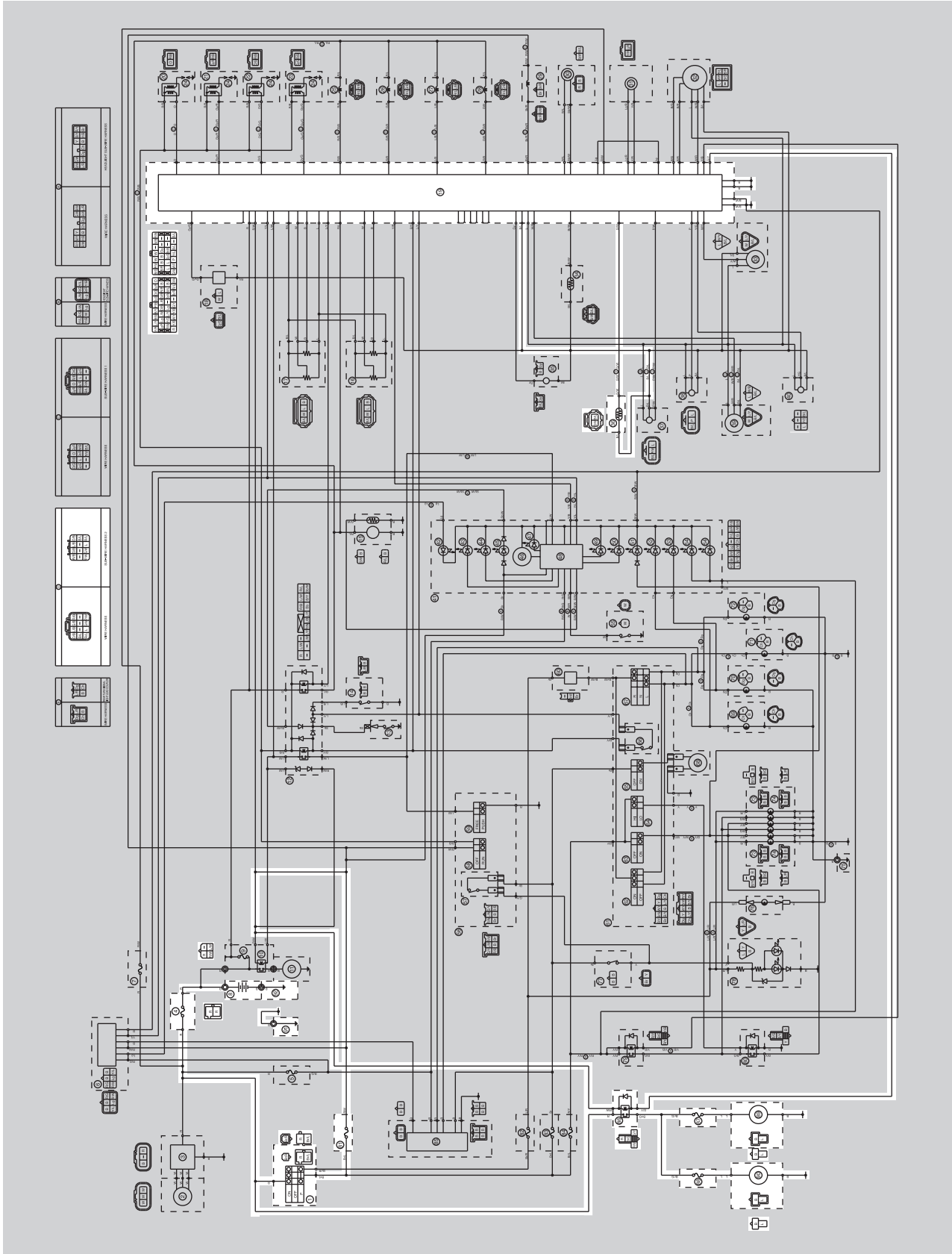

## COOLING SYSTEM

---

- 1. Main switch
- 4. Main fuse
- 8. Battery
- 19.ECU (engine control unit)
- 36.Coolant temperature sensor
- 81.Ignition fuse
- 86.Radiator fan motor relay
- 87.Right radiator fan motor fuse
- 88.Left radiator fan motor fuse
- 89.Right radiator fan motor
- 90.Left radiator fan motor
- 91.Ground
- 92.Battery negative lead

## COOLING SYSTEM

EAS27320

### TROUBLESHOOTING

**NOTE:**

- Before troubleshooting, remove the following part(s):

- 1 Rider seat
- 2 Passenger seat
- 3 Fuel tank
- 4 Side cowling

<p>1 Check the fuses. (Main, ignition and radiator fan motor) Refer to "CHECKING THE FUSES" on page 8-89.</p>	NG→	<p>Replace the fuse(s).</p>
OK↓		
<p>2 Check the battery. Refer to "CHECKING AND CHARGING THE BATTERY" on page 8-89.</p>	NG→	<ul style="list-style-type: none"> <li>• Clean the battery terminals.</li> <li>• Recharge or replace the battery.</li> </ul>
OK↓		
<p>3 Check the main switch. Refer to "CHECKING THE SWITCHES" on page 8-85.</p>	NG→	<p>Replace the immobilizer unit.</p>
OK↓		
<p>4 Check the radiator fan motor. Refer to "CHECKING THE RADIATOR FAN MOTORS" on page 8-100.</p>	NG→	<p>The radiator fan motor is faulty and must be replaced.</p>
OK↓		
<p>5 Check the radiator fan motor relay. Refer to "CHECKING THE RELAYS" on page 8-92.</p>	NG→	<p>Replace the radiator fan motor relay.</p>
OK↓		
<p>6 Check the coolant temperature. Refer to "CHECKING THE COOLANT TEMPERATURE SENSOR" on page 8-100.</p>	NG→	<p>Replace the coolant temperature sensor.</p>
OK↓		

## COOLING SYSTEM

---

7 Check the entire cooling system's wiring.  
Refer to "COOLING SYSTEM" on page 8-25.

OK↓

This circuit is OK.

NG→

Properly connect or repair the cooling system's wiring.

# FUEL INJECTION SYSTEM

EAS27330

## FUEL INJECTION SYSTEM

EAS27340

## CIRCUIT DIAGRAM

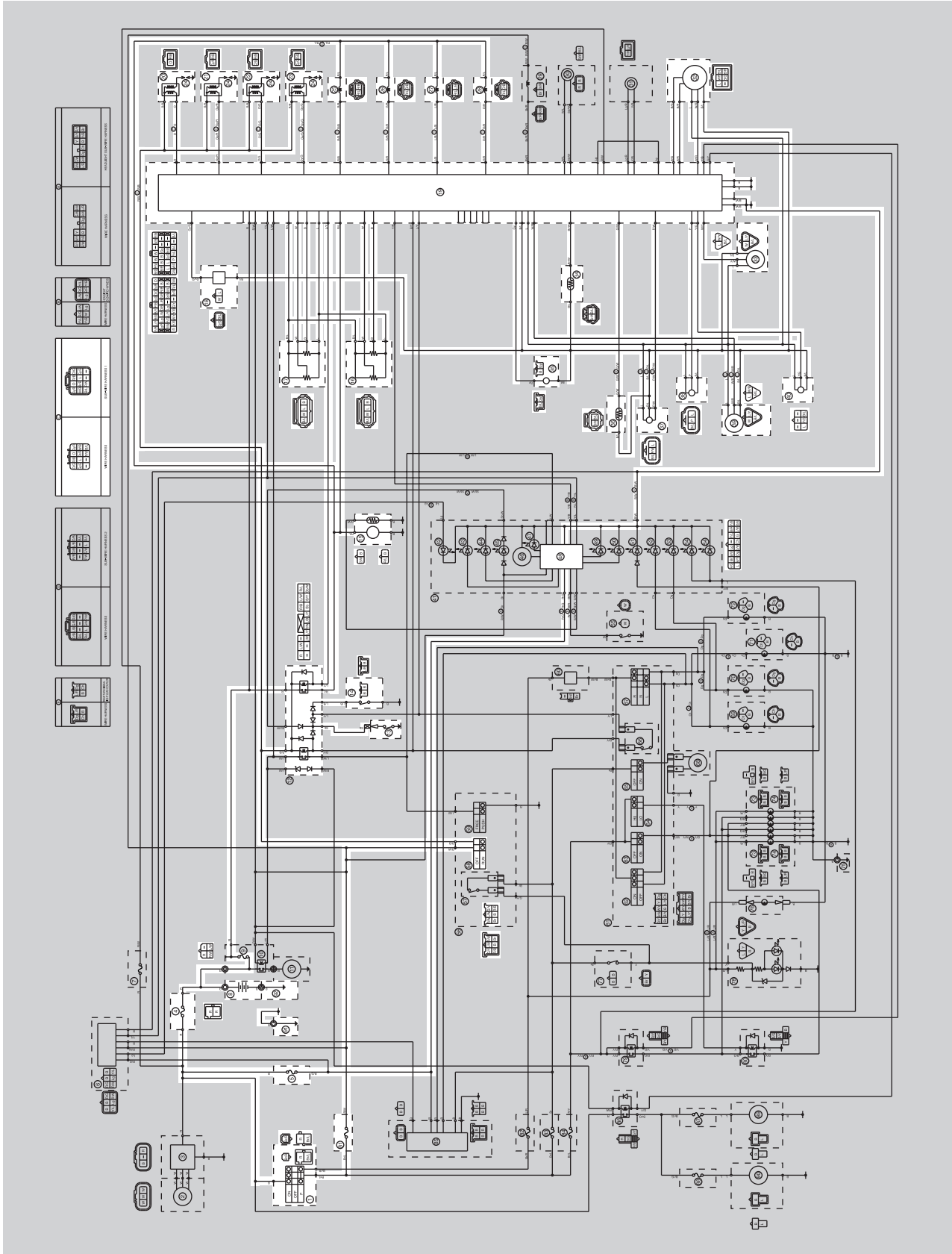

## FUEL INJECTION SYSTEM

---

1. Main switch
4. Main fuse
5. Backup fuse
8. Battery
9. Fuel injection system fuse
12. Starting circuit cut-off relay
13. Neutral switch
14. Sidestand switch
15. Fuel pump
16. Throttle position sensor (for throttle valves)
17. Throttle position sensor (for throttle cable pulley)
18. O<sub>2</sub> sensor
19. ECU (engine control unit)
20. Ignition coil #1
21. Ignition coil #2
22. Ignition coil #3
23. Ignition coil #4
24. Spark plug
25. Injector #1
26. Injector #2
27. Injector #3
28. Injector #4
32. EXUP servo motor
33. Speed sensor
34. Intake air temperature sensor
35. Crankshaft position sensor
36. Coolant temperature sensor
37. Intake air pressure sensor
38. Atmospheric pressure sensor
39. Cylinder identification sensor
40. Lean angle sensor
48. Multi-function meter
58. Engine stop switch
81. Ignition fuse
91. Ground
92. Battery negative lead

## FUEL INJECTION SYSTEM

EAS27350

### ECU SELF-DIAGNOSTIC FUNCTION

The ECU is equipped with a self-diagnostic function in order to ensure that the fuel injection system is operating normally. If this function detects a malfunction in the system, it immediately operates the engine under substitute characteristics and illuminates the engine trouble warning light to alert the rider that a malfunction has occurred in the system. Once a malfunction has been detected, a fault code is stored in the memory of the ECU.

- To inform the rider that the fuel injection system is not functioning, the engine trouble warning light flashes when the start switch is being pushed to start the engine.
- If a malfunction is detected in the system by the self-diagnostic function, the ECU provides an appropriate substitute characteristic operation, and alerts the rider of the detected malfunction by illuminating the engine trouble warning light.
- After the engine has been stopped, the lowest fault code number appears on the odometer/trip meter/fuel reservoir trip meter/stop watch LCD. Once a fault code has been displayed, it remains stored in the memory of the ECU until it is deleted.

### Engine trouble warning light indication and FI system operation

Warning light indication	ECU operation	FI operation	Vehicle operation
Flashing*	Warning provided when unable to start engine	Operation stopped	Cannot be operated
Remains on	Malfunction detected	Operated with substitute characteristics in accordance with the description of the malfunction	Can or cannot be operated depending on the fault code

\* The warning light flashes when any one of the conditions listed below is present and the start switch is pushed:

- |  |  |
|--|--|
| 11: Cylinder identification sensor                         | 30: Lean angle sensor (latch up detected)        |
| 12: Crankshaft position sensor                             | 41: Lean angle sensor (open or short-circuit)    |
| 19: Sidestand switch (open circuit in the wire to the ECU) | 50: ECU internal malfunction (faulty ECU memory) |

### Checking engine trouble warning light

The engine trouble warning light comes on for 1.4 seconds after the main switch has been turned to "ON" and it comes on while the start switch is being pushed. If the warning light does not come on under these conditions, the warning light (LED) may be defective.

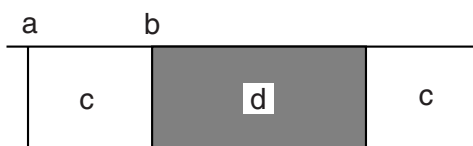

## FUEL INJECTION SYSTEM

---

- a. Main switch "OFF"
- b. Main switch "ON"
- c. Engine trouble warning light off
- d. Engine trouble warning light on for 1.4 seconds

**FUEL INJECTION SYSTEM**

EAS27362

**FAIL-SAFE ACTIONS (SUBSTITUTE CHARACTERISTICS OPERATION CONTROL)**

If the ECU detects an abnormal signal from a sensor while the vehicle is being driven, the ECU illuminates the engine trouble warning light and provides the engine with alternate operating instructions that are appropriate for the type of malfunction.

When an abnormal signal is received from a sensor, the ECU processes the specified values that are programmed for each sensor in order to provide the engine with alternate operating instructions that enable the engine to continue to operate or stop operating, depending on the conditions.

**Self-Diagnostic Function table**

<b>Fault code No.</b>	<b>Item</b>	<b>Symptom</b>	<b>Able / unable to start</b>	<b>Able / unable to drive</b>
11	Cylinder identification sensor	<ul style="list-style-type: none"> <li>No normal signals are received from the cylinder identification sensor.</li> <li>Malfunction of electric starting system.</li> </ul>	Unable	Able
12	Crankshaft position sensor	No normal signals are received from the crankshaft position sensor.	Unable	Unable
13	Intake air pressure sensor (open or short circuit)	Intake air pressure sensor-open or short circuit detected.	Able	Able
14	Intake air pressure sensor (pipe system)	Intake air pressure sensor-pipe system malfunction (clogged or detached hose).	Able	Able
15	Throttle position sensor (for throttle valves) (open or short circuit/ loose connection)	Throttle position sensor (for throttle valves): open or short circuit detected. Throttle position sensor (for throttle valves) coupler connection is loose.	Able/Unable	Able/Unable
17	EXUP servo motor circuit (open or short circuit)	EXUP servo motor circuit: open or short circuit detected.	Able	Able
18	EXUP servo motor (stuck)	EXUP servo motor is stuck.	Able	Able
19	Sidestand switch (open circuit wire harness to ECU)	Open circuit is detected in the input line from the sidestand switch to the ECU.	Unable	Unable
20	Intake air pressure sensor Atmospheric pressure sensor	Intake air pressure sensor-open or short circuit detected. Defective values are detected due to the internal malfunction of the intake air pressure sensor or the Atmospheric pressure sensor.	Able	Able
21	Coolant temperature sensor	Coolant temperature sensor-open or short circuit detected.	Able	Able
22	Intake air temperature sensor	Intake air temperature sensor-open or short circuit detected.	Able	Able

**FUEL INJECTION SYSTEM**

<b>Fault code No.</b>	<b>Item</b>	<b>Symptom</b>	<b>Able / unable to start</b>	<b>Able / unable to drive</b>
23	Atmospheric pressure sensor	Atmospheric pressure sensor-open or short circuit detected.	Able	Able
24	O <sub>2</sub> sensor	No normal signal is received from the O <sub>2</sub> sensor.	Able	Able
30	Lean angle sensor	Latch up detected. No normal signal is received from the lean angle sensor.	Unable	Unable
33	Ignition coil (#1) (faulty ignition)	Malfunction detected in the primary wire of the ignition coil (#1).	Able (depending on the number of faulty cylinders)	Able (depending on the number of faulty cylinders)
34	Ignition coil (#2) (faulty ignition)	Malfunction detected in the primary wire of the ignition coil (#2).	Able (depending on the number of faulty cylinders)	Able (depending on the number of faulty cylinders)
35	Ignition coil (#3) (faulty ignition)	Malfunction detected in the primary wire of the ignition coil (#3).	Able (depending on the number of faulty cylinders)	Able (depending on the number of faulty cylinders)
36	Ignition coil (#4) (faulty ignition)	Malfunction detected in the primary wire of the ignition coil (#4).	Able (depending on the number of faulty cylinders)	Able (depending on the number of faulty cylinders)
39	Injector (open circuit)	Injector: open circuit detected.	Able (depending on the number of faulty cylinders)	Able (depending on the number of faulty cylinders)
41	Lean angle sensor (open or short circuit)	Lean angle sensor-open or short circuit detected.	Unable	Unable
42	Speed sensor Neutral switch	No normal signals are received from the speed sensor. Open or short circuit is detected in the neutral switch.	Able	Able
43	Fuel system voltage (monitor voltage)	The ECU is unable to monitor the battery voltage (an open circuit in the line to the ECU).	Able	Able
44	Error in writing the amount of CO adjustment on EEPROM	Error is detected while reading or writing on EEPROM (CO adjustment value).	Able	Able
46	Vehicle system power supply (Monitoring voltage)	Power supply to the fuel injection system is not normal.	Able	Able

## FUEL INJECTION SYSTEM

Fault code No.	Item	Symptom	Able / unable to start	Able / unable to drive
50	ECU internal malfunction	ECU memory is faulty. (When this malfunction is detected in the ECU, the fault code number might not appear on the meter.)	Able/Unable	Able/Unable
59	Throttle position sensor (for throttle cable pulley) (open or short circuit/ loose connection)	Throttle position sensor (for throttle cable pulley): open or short circuit detected. Throttle position sensor (for throttle cable pulley) coupler connection is loose.	Able/Unable	Able/Unable
60	Throttle servo motor	Throttle servo motor: open or short circuit detected. Motor is defective or ECU internal malfunction.	Able/Unable	Able/Unable

### Communication error with the meter

Fault code No.	Item	Symptom	Able / unable to start	Able / unable to drive
Er-1	ECU internal malfunction (output signal error)	No signals are received from the ECU.	Unable	Unable
Er-2	ECU internal malfunction (output signal error)	No signals are received from the ECU within the specified duration.	Unable	Unable
Er-3	ECU internal malfunction (output signal error)	Data from the ECU cannot be received correctly.	Unable	Unable
Er-4	ECU internal malfunction (input signal error)	Non-registered data has been received from the meter.	Unable	Unable

## FUEL INJECTION SYSTEM

EAS27400

### TROUBLESHOOTING METHOD

**The engine operation is not normal and the engine trouble warning light comes on.**

1. Check:
  - Fault code number



- a. Check the fault code number displayed on the meter.
- b. Identify the faulty system with the fault code. Refer to "Self-Diagnostic Function table".
- c. Identify the probable cause of malfunction. Refer to "Fault code table".



2. Checking and repair the probable cause of malfunction.

Fault code No.	No fault code No.
Check and repair. Refer to "TROUBLE-SHOOTING DETAILS" on page 8-45. Monitor the operation of the sensors and actuators in the diagnostic mode. Refer to "Sensor operation table" and "Actuator operation table".	Check and repair. Refer to "TROUBLE-SHOOTING DETAILS" on page 8-45.

3. Perform fuel injection table reinstatement action. Refer to "Reinstatement method" of table in "TROUBLESHOOTING DETAILS".
4. Turn the main switch to "OFF" and back to "ON", then check the fault code number is displayed.

**NOTE:**

If fault code are displayed, repeat steps (1) to (4) until no fault code number is displayed.

5. The Malfunction history is stored even if the main switch is turned OFF. The malfunction history must be erased in the diagnostic mode. Refer to "Sensor operation table (Diagnostic code No.62)".

**The engine operation is not normal but the engine trouble warning light does not come on.**

1. Check the operation of following sensors and actuators in the Diagnostic mode. Refer to "Sensor operation table" and "Actuator operation table".

01: Throttle position sensor (for throttle valves) signal 1 (throttle angle)
13: Throttle position sensor (for throttle valves) signal 2 (throttle angle)
14: Throttle position sensor (for throttle cable pulley) signal 1 (throttle angle)
15: Throttle position sensor (for throttle cable pulley) signal 2 (throttle angle)
30: Ignition coil #1
31: Ignition coil #2
32: Ignition coil #3
33: Ignition coil #4
36: Injector #1
37: Injector #2
38: Injector #3
39: Injector #4
48: AI system solenoid

If a malfunction is detected in the sensors or actuators, repair or replace all faulty parts.

If no malfunction is detected in the sensors and actuators, check and repair inner parts of the engine.

## FUEL INJECTION SYSTEM

EAS27421

### DIAGNOSTIC MODE

Setting the diagnostic mode

1. Turn the main switch to “OFF” and set the engine stop switch to “ON”.
2. Disconnect the wire harness coupler from the fuel pump.
3. Simultaneously press and hold the “SELECT” and “RESET” buttons, turn the main switch to “ON”, and continue to press the buttons for 8 seconds or more.

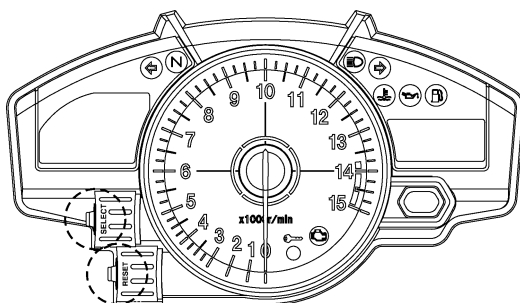

#### NOTE:

- All displays on the meter disappear except the odometer/trip meter/fuel reservoir trip meter/stop watch displays.
- “DIAG” appears on the odometer/trip meter/fuel reservoir trip meter/stop watch LCD.

4. Press the “SELECT” button to select the diagnostic mode “DIAG”.
5. After selecting “DIAG”, simultaneously press the “SELECT” and “RESET” buttons for 2 seconds or more to activate the diagnostic mode. The diagnostic code number “d01” appears on the odometer/trip meter/fuel reservoir trip meter/stop watch LCD.
6. Set the engine stop switch to “OFF”.
7. Select the diagnostic code number corresponding to the fault code number by pressing the “SELECT” and “RESET” buttons.

#### NOTE:

The diagnostic code number appears on the odometer/trip meter/fuel reservoir trip meter/stop watch LCD (01–70).

- To decrease the selected diagnostic code number, press the “RESET” button. Press the “RESET” button for 1 second or longer to automatically decrease the diagnostic code numbers.
- To increase the selected diagnostic code number, press the “SELECT” button. Press the “SELECT” button for 1 second or longer to automatically increase the diagnostic code numbers.

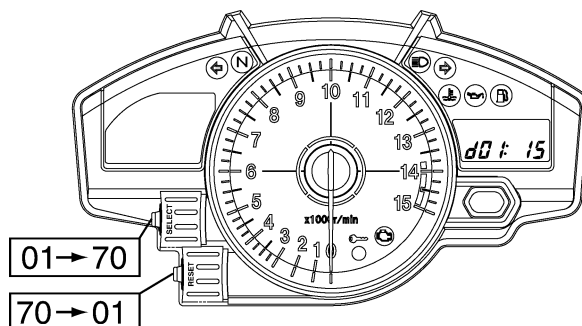

8. Verify the operation of the sensor or actuator.
  - Sensor operation  
The data representing the operating conditions of the sensor appears on the odometer/trip meter/fuel reservoir trip meter/stop watch LCD.
  - Actuator operation  
Set the engine stop switch to “○” to operate the actuator.

**FUEL INJECTION SYSTEM****NOTE:**

If the engine stop switch is set to “○”, set it to “⊗”, and then set it to “○” again.

9. Turn the main switch to “OFF” to cancel the diagnostic mode.

**Fault code table**

<b>Fault code No.</b>	<b>Symptom</b>	<b>Probable cause of malfunction</b>	<b>Diagnostic code No.</b>
11	No normal signals are received from the cylinder identification sensor when the engine is started or while the vehicle is being driven.	<ul style="list-style-type: none"> <li>• Open or short circuit in sub-wire-harness 1.</li> <li>• Open or short circuit in wire harness.</li> <li>• Defective cylinder identification sensor.</li> <li>• Malfunction in ECU.</li> <li>• Improperly installed sensor.</li> </ul>	—
12	No normal signals are received from the crankshaft position sensor.	<ul style="list-style-type: none"> <li>• Open or short circuit in wire harness.</li> <li>• Defective crankshaft position sensor.</li> <li>• Malfunction in pickup rotor.</li> <li>• Malfunction in ECU.</li> <li>• Improperly installed sensor.</li> </ul>	—
13	Intake air pressure sensor: open or short circuit detected.	<ul style="list-style-type: none"> <li>• Open or short circuit in wire harness.</li> <li>• Defective intake air pressure sensor.</li> <li>• Malfunction in ECU.</li> </ul>	03
14	Intake air pressure sensor: hose system malfunction (clogged or detached hose).	<ul style="list-style-type: none"> <li>• Intake air pressure sensor hose is detached, clogged, kinked, or pinched.</li> <li>• Malfunction in ECU.</li> </ul>	03
15	Throttle position sensor (for throttle valves): open or short circuit detected. Throttle position sensor (for throttle valves) coupler connection is loose.	<ul style="list-style-type: none"> <li>• Open or short circuit in wire harness.</li> <li>• Defective throttle position sensor (for throttle valves).</li> <li>• Malfunction in ECU.</li> <li>• Improperly installed throttle position sensor (for throttle valves).</li> </ul>	01 13
17	EXUP servo motor circuit: open or short circuit detected or loose connection.	<ul style="list-style-type: none"> <li>• Open or short circuit in wire harness.</li> <li>• Defective EXUP servo motor (potentiometer circuit).</li> </ul>	53
18	EXUP servo motor is stuck.	<ul style="list-style-type: none"> <li>• Open or short circuit in wire harness.</li> <li>• Stuck EXUP servo motor (mechanism).</li> <li>• Stuck EXUP servo motor (motor).</li> </ul>	53
19	Open circuit is detected in the input lead from the side-stand switch to the ECU.	<ul style="list-style-type: none"> <li>• Open circuit in wire harness (ECU Coupler).</li> <li>• Malfunction in ECU.</li> <li>• Relay unit (diode)</li> </ul>	20

## FUEL INJECTION SYSTEM

Fault code No.	Symptom	Probable cause of malfunction	Diagnostic code No.
20	When the main switch is turned to "ON", the atmospheric pressure sensor voltage and intake air pressure sensor voltage differ greatly.	<ul style="list-style-type: none"> <li>• Atmospheric pressure sensor hose is clogged.</li> <li>• Intake air pressure sensor hose is clogged, kinked, or pinched.</li> <li>• Malfunction of the atmospheric pressure sensor in the intermediate electrical potential.</li> <li>• Malfunction of the intake air pressure sensor in the intermediate electrical potential.</li> <li>• Malfunction in ECU.</li> </ul>	03 02
21	Coolant temperature sensor: open or short circuit detected.	<ul style="list-style-type: none"> <li>• Open or short circuit in wire harness.</li> <li>• Defective coolant temperature sensor.</li> <li>• Malfunction in ECU.</li> <li>• Improperly installed coolant temperature sensor.</li> </ul>	06
22	Air temperature sensor: open or short circuit detected.	<ul style="list-style-type: none"> <li>• Open or short circuit in wire harness.</li> <li>• Defective air temperature sensor.</li> <li>• Malfunction in ECU.</li> <li>• Improperly installed air temperature sensor.</li> </ul>	05
23	Atmospheric pressure sensor: open or short circuit detected.	<ul style="list-style-type: none"> <li>• Open or short circuit in wire harness.</li> <li>• Defective atmospheric pressure sensor.</li> <li>• Improperly installed atmospheric pressure sensor.</li> <li>• Malfunction in ECU.</li> </ul>	02
24	No normal signal is received from the O <sub>2</sub> sensor.	<ul style="list-style-type: none"> <li>• Open or short circuit in wire harness.</li> <li>• Defective O<sub>2</sub> sensor.</li> <li>• Malfunction in ECU.</li> <li>• Improperly installed O<sub>2</sub> sensor.</li> </ul>	—
30	Latch up detected. No normal signal is received from the lean angle sensor.	<ul style="list-style-type: none"> <li>• The vehicle has overturned.</li> <li>• Defective lean angle sensor.</li> <li>• Malfunction in ECU.</li> <li>• Improperly installed lean angle sensor.</li> </ul>	08
33	Open circuit detected in the primary lead of the cylinder-#1 ignition coil.	<ul style="list-style-type: none"> <li>• Open circuit in wire harness.</li> <li>• Malfunction in ignition coil.</li> <li>• Malfunction in ECU.</li> </ul>	30
34	Open circuit detected in the primary lead of the cylinder-#2 ignition coil.	<ul style="list-style-type: none"> <li>• Open circuit in wire harness.</li> <li>• Malfunction in ignition coil.</li> <li>• Malfunction in ECU.</li> </ul>	31
35	Open circuit detected in the primary lead of the cylinder-#3 ignition coil.	<ul style="list-style-type: none"> <li>• Open circuit in wire harness.</li> <li>• Malfunction in ignition coil.</li> <li>• Malfunction in ECU.</li> </ul>	32
36	Open circuit detected in the primary lead of the cylinder-#4 ignition coil.	<ul style="list-style-type: none"> <li>• Open circuit in wire harness.</li> <li>• Malfunction in ignition coil.</li> <li>• Malfunction in ECU.</li> </ul>	33
39	Open circuit detected in a injector.	<ul style="list-style-type: none"> <li>• Open or short circuit in wire harness.</li> <li>• Defective primary injector.</li> <li>• Malfunction in ECU.</li> <li>• Improperly installed primary injector.</li> </ul>	36 37 38 39

**FUEL INJECTION SYSTEM**

<b>Fault code No.</b>	<b>Symptom</b>	<b>Probable cause of malfunction</b>	<b>Diagnostic code No.</b>
41	Lean angle sensor: open or short circuit detected.	<ul style="list-style-type: none"> <li>• Open or short circuit in wire harness.</li> <li>• Defective lean angle sensor.</li> <li>• Malfunction in ECU.</li> </ul>	08
42	No normal signals are received from the speed sensor.	<ul style="list-style-type: none"> <li>• Open circuit in wire harness.</li> <li>• Malfunction in speed sensor.</li> <li>• Malfunction in ECU.</li> </ul>	07
	Neutral switch: open or short circuit detected.	<ul style="list-style-type: none"> <li>• Open circuit in wire harness.</li> <li>• Malfunction in neutral switch.</li> <li>• Malfunction in ECU.</li> </ul>	21
43	Power supply to the injectors and the fuel pump is not normal.	<ul style="list-style-type: none"> <li>• Open or short circuit in wire harness.</li> <li>• Malfunction in ECU.</li> </ul>	09
44	An error is detected while reading or writing on EEPROM (CO adjustment value).	<ul style="list-style-type: none"> <li>• Malfunction in ECU. (The CO adjustment value is not properly written on or read from the internal memory).</li> </ul>	60
46	Power supply is not normal.	Malfunction in the charging system. Refer to "CHARGING SYSTEM" on page 8-11.	—
50	Faulty ECU memory. (When this malfunction is detected in the ECU, the fault code number might not appear on the meter.)	<ul style="list-style-type: none"> <li>• Malfunction in ECU. (The program and data are not properly written on or read from the internal memory.)</li> </ul>	—
59	Throttle position sensor (for throttle cable pulley): open or short circuit detected. Throttle position sensor (for throttle cable pulley) coupler connection is loose.	<ul style="list-style-type: none"> <li>• Open or short circuit in wire harness.</li> <li>• Defective throttle position sensor.</li> <li>• Improperly installed throttle position sensor.</li> <li>• Malfunction in ECU.</li> </ul>	14
			15
60	Throttle servo motor: open or short circuit detected. Defective throttle servo motor. Malfunction in ECU (servo motor driving system).	<ul style="list-style-type: none"> <li>• Open or short circuit in wire harness.</li> <li>• Defective throttle servo motor (potentiometer circuit).</li> <li>• Stuck throttle servo motor (mechanism).</li> <li>• Stuck throttle servo motor (motor).</li> <li>• Malfunction in ECU.</li> </ul>	01
Er-1	No signals are received from the ECU.	<ul style="list-style-type: none"> <li>• Open or short circuit in wire harness.</li> <li>• Malfunction in meter.</li> <li>• Malfunction in ECU.</li> <li>• Defective wire connection of the ECU coupler.</li> </ul>	—
Er-2	No signals are received from the ECU within the specified duration.	<ul style="list-style-type: none"> <li>• Improper connection in wire harness.</li> <li>• Malfunction in meter.</li> <li>• Malfunction in ECU.</li> </ul>	—
Er-3	Data from the ECU cannot be received correctly.	<ul style="list-style-type: none"> <li>• Improper connection in wire harness.</li> <li>• Malfunction in meter.</li> <li>• Malfunction in ECU.</li> </ul>	—

## FUEL INJECTION SYSTEM

Fault code No.	Symptom	Probable cause of malfunction	Diagnostic code No.
Er-4	Non-registered data has been received from the meter.	<ul style="list-style-type: none"> <li>• Improper connection in wire harness.</li> <li>• Malfunction in meter.</li> <li>• Malfunction in ECU.</li> </ul>	—

### Sensor operation table

Diagnostic code No.	Item	Meter display	Checking method
01	Throttle position sensor (for throttle valves) signal 1 <ul style="list-style-type: none"> <li>• Fully closed position</li> <li>• Fully opened position</li> </ul>	12–21  97–106	Check with throttle valves fully closed.  Check with throttle valves fully opened.
02	Atmospheric pressure	Displays the atmospheric pressure.	Compare the actually measured atmospheric pressure with the meter display value.
03	Intake air pressure	Displays intake air pressure.	Compare the actually measured atmospheric pressure with the meter display value without cranking the engine.
05	Intake air temperature	Displays the intake air temperature.	Compare the actually measured air temperature with the meter display value.
06	Coolant temperature	Displays the coolant temperature.	Compare the actually measured coolant temperature with the meter display value.
07	Vehicle speed pulse	0–999	Check that the number increases when the rear wheel is rotated. The number is cumulative and does not reset each time the wheel is stopped.
08	Lean angle sensor <ul style="list-style-type: none"> <li>• Upright</li> <li>• Overturned</li> </ul>	0.4–1.4 3.7–4.4	Remove the lean angle sensor and incline it more than 65 degrees.
09	Fuel system voltage (battery voltage)	Approximately 12.0	Set the engine stop switch to “○”, and then compare with the actually measured battery voltage. (If the battery voltage is lower, recharge the battery.)

## FUEL INJECTION SYSTEM

Diagnostic code No.	Item	Meter display	Checking method
13	Throttle position sensor (for throttle valves) signal 2 <ul style="list-style-type: none"> <li>• Fully closed position</li> <li>• Fully opened position</li> </ul>	9-23  94-108	Check with throttle valve fully closed. Check with throttle valve fully opened.
14	Throttle position sensor (for throttle cable pulley) signal 1 <ul style="list-style-type: none"> <li>• Fully closed position</li> <li>• Fully opened position</li> </ul>	12-22  97-107	Check with throttle grip fully closed. Check with throttle grip fully opened.
15	Throttle position sensor (for throttle cable pulley) signal 2 <ul style="list-style-type: none"> <li>• Fully closed position</li> <li>• Fully opened position</li> </ul>	10-24  95-109	Check with throttle grip fully closed. Check with throttle grip fully opened.
20	Sidestand switch <ul style="list-style-type: none"> <li>• Stand retracted</li> <li>• Stand extended</li> </ul>	ON OFF	Set ON/OFF the sidestand switch (with the transmission in gear).
21	Neutral switch <ul style="list-style-type: none"> <li>• Neutral</li> <li>• In gear</li> </ul>	ON OFF	Shift the transmission.
60	EEPROM fault cylinder No. <ul style="list-style-type: none"> <li>• No history</li> <li>• History exists</li> </ul>	00 01-04 (fault cylinder No.) <ul style="list-style-type: none"> <li>• (If more than one cylinder is defective, the display changes every two seconds to show all the detected cylinder numbers. When all cylinder numbers are shown, the display repeats.)</li> </ul>	—
61	Malfunction history code <ul style="list-style-type: none"> <li>• No history</li> <li>• History exists</li> </ul>	00 11-60 (Fault detection code) <ul style="list-style-type: none"> <li>• (If more than one code number is detected, the display changes every two seconds to show all the detected code numbers. When all code numbers are shown, the display repeats.)</li> </ul>	—

## FUEL INJECTION SYSTEM

Diagnostic code No.	Item	Meter display	Checking method
62	Malfunction history code erasure • No history • History exists	00 • Displays the total number of malfunctions, including the current malfunction, that have occurred since the history was last erased. (For example, if there have been three malfunctions, "03" is displayed.)	—  To erase the history, set the engine stop switch from "⊗" to "○".
63	Malfunction code reinstate (for fault code No. 24 only) • No malfunction code • Malfunction code exists	00 Fault codes 24 • (If more than one code number is detected, the display changes every two seconds to show all the detected code numbers. When all code numbers are shown, the display repeats.)	—  To erase the history, set the engine stop switch from "⊗" to "○".
70	Control number	00	—

### Actuator operation table

Diagnostic code No.	Item	Actuation	Checking method
30	Cylinder-#1 ignition coil	Actuates the cylinder-#1 ignition coil five times at one-second intervals. Illuminates the engine trouble warning light.	Check the spark five times. • Connect an ignition checker.
31	Cylinder-#2 ignition coil	Actuates the cylinder-#2 ignition coil five times at one-second intervals. Illuminates the engine trouble warning light.	Check the spark five times. • Connect an ignition checker.
32	Cylinder-#3 ignition coil	Actuates the cylinder-#3 ignition coil five times at one-second intervals. Illuminates the engine trouble warning light.	Check the spark five times. • Connect an ignition checker.

**FUEL INJECTION SYSTEM**

<b>Diagnostic code No.</b>	<b>Item</b>	<b>Actuation</b>	<b>Checking method</b>
33	Cylinder-#4 ignition coil	Actuates the cylinder-#4 ignition coil five times at one-second intervals. Illuminates the engine trouble warning light.	Check the spark five times. • Connect an ignition checker.
34	Intake funnel	Actuates the intake funnel (up position down position for each 3 seconds). Illuminates the engine trouble warning light.	Check the operating sound of the intake funnel.
36	Injector #1	Actuates the injector #1 five times at one-second intervals. Illuminates the engine trouble warning light.	Check the operating sound of the primary injector #1 five times.
37	Injector #2	Actuates the injector #2 five times at one-second intervals. Illuminates the engine trouble warning light.	Check the operating sound of the primary injector #2 five times.
38	Injector #3	Actuates the injector #3 five times at one-second intervals. Illuminates the engine trouble warning light.	Check the operating sound of the primary injector #3 five times.
39	Injector #4	Actuates the injector #4 five times at one-second intervals. Illuminates the engine trouble warning light.	Check the operating sound of the primary injector #4 five times.
48	Air induction system solenoid	Actuates the air induction system solenoid five times at one-second intervals. Illuminates the engine trouble warning light.	Check the operating sound of the air induction system solenoid five times.
50	Fuel injection system relay	Actuates the fuel injection system relay five times at one-second intervals. Illuminates the engine trouble warning light. (The engine trouble warning light is OFF when the relay is ON, and the engine trouble warning light is ON when the relay is OFF).	Check the operating sound of the fuel injection system relay five times.

## FUEL INJECTION SYSTEM

Diagnostic code No.	Item	Actuation	Checking method
51	Radiator fan motor relay	Actuates the radiator fan motor relay five times at one second intervals. (ON 2 seconds, OFF 3 seconds) Illuminates the engine trouble warning light.	Check the operating sound of the radiator fan motor relay five times.
52	Headlight relay	Actuates the headlight relay five times at one-second intervals. (ON 2 seconds, OFF 3 seconds) Illuminates the engine trouble warning light.	Check the operating sound of the headlight relay five times.
53	EXUP servo motor	Actuates the servo motor (turns to open side and to closed side). Illuminates the engine trouble warning light.	Check the operating sound.

EAS27461

### TROUBLESHOOTING DETAILS

This section describes the measures per fault code number displayed on the meter. Check and service the items or components that are the probable cause of the malfunction following the order given.

After the check and service of the malfunctioning part has been completed, reset the meter display according to the reinstatement method.

Fault code No.:

Code number displayed on the meter when the engine failed to work normally. Refer to "Self-Diagnostic Function table".

Diagnostic code No.:

Diagnostic code number to be used when the diagnostic mode is operated. Refer to "DIAGNOSTIC MODE" on page 8-37.

## FUEL INJECTION SYSTEM

<b>Fault code No.</b>	11	<b>Symptom</b>	No normal signals are received from the cylinder identification sensor when the engine is started or while the vehicle is being driven.	
<b>Diagnostic code No.</b>		—	—	
Order	Item/components and probable cause	Check or maintenance job	Reinstatement method	
1	Installed condition of cylinder identification sensor.	Check for looseness or pinching.	Cranking the engine.	
2	Connections <ul style="list-style-type: none"> <li>• Cylinder identification sensor coupler</li> <li>• Main wire harness ECU coupler</li> </ul>	<ul style="list-style-type: none"> <li>• Check the couplers for any pins that may be pulled out.</li> <li>• Check the locking condition of the couplers.</li> <li>• If there is a malfunction, repair it and connect the coupler securely.</li> </ul>		
3	Open or short circuit in wire harness.	<ul style="list-style-type: none"> <li>• Repair or replace if there is an open or short circuit.</li> <li>• Between the cylinder identification sensor coupler and ECU coupler. (Blue–Blue) (White/Black–White/Black) (Black/Blue–Black/Blue)</li> </ul>		
4	Defective cylinder identification sensor.	<ul style="list-style-type: none"> <li>• Replace if defective. Refer to "CHECKING THE CYLINDER IDENTIFICATION SENSOR" on page 8-102.</li> </ul>		

## FUEL INJECTION SYSTEM

<b>Fault code No.</b>	<b>12</b>	<b>Symptom</b>	<b>No normal signals are received from the crankshaft position sensor.</b>	
<b>Diagnostic code No.</b>	—		—	
Order	Item/components and probable cause	Check or maintenance job	Reinstatement method	
1	Installed condition of crankshaft position sensor	Check for looseness or pinching.	Cranking the engine.	
2	Connections <ul style="list-style-type: none"> <li>• Crankshaft position sensor coupler</li> <li>• Main wire harness ECU coupler</li> </ul>	<ul style="list-style-type: none"> <li>• Check the coupler for any pins that may have pulled out.</li> <li>• Check the locking condition of the coupler.</li> <li>• If there is a malfunction, repair it and connect the coupler securely.</li> </ul>		
3	Open or short circuit in wire harness.	<ul style="list-style-type: none"> <li>• Repair or replace if there is an open or short circuit.</li> <li>• Between the crankshaft position sensor coupler and ECU coupler. (Gray–Gray) (Black/Blue–Black/Blue)</li> </ul>		
4	Defective crankshaft position sensor.	<ul style="list-style-type: none"> <li>• Replace if defective. Refer to "CHECKING THE CRANKSHAFT POSITION SENSOR" on page 8-96.</li> </ul>		

<b>Fault code No.</b>	<b>13</b>	<b>Symptom</b>	<b>Intake air pressure sensor: open or short circuit detected.</b>	
<b>Diagnostic code No.</b>	03		<b>Intake air pressure sensor</b>	
Order	Item/components and probable cause	Check or maintenance job	Reinstatement method	
1	Connections <ul style="list-style-type: none"> <li>• Intake air pressure sensor coupler</li> <li>• Main wire harness ECU coupler</li> </ul>	<ul style="list-style-type: none"> <li>• Check the coupler for any pins that may be pulled out.</li> <li>• Check the locking condition of the coupler.</li> <li>• If there is a malfunction, repair it and connect the coupler securely.</li> </ul>	Reinstated automatically if a normal signal is received.	
2	Open or short circuit in wire harness and/or sub-wire-harness 2.	<ul style="list-style-type: none"> <li>• Repair or replace if there is an open or short circuit.</li> <li>• Between intake air pressure sensor coupler and ECU coupler (Black/Blue–Black/Blue) (Pink/White–Pink/White) (Blue–Blue)</li> </ul>		
3	Defective intake air pressure sensor.	<ul style="list-style-type: none"> <li>• Execute the diagnostic mode. (Code No.03)</li> <li>• Replace if defective. Refer to "CHECKING THE INTAKE AIR PRESSURE SENSOR" on page 8-103.</li> </ul>		

## FUEL INJECTION SYSTEM

<b>Fault code No.</b>	<b>14</b>	<b>Symptom</b>	<b>Intake air pressure sensor: hose system malfunction (clogged or detached hose).</b>	
<b>Diagnostic code No.</b>		<b>03</b>	<b>Intake air pressure sensor</b>	
<b>Order</b>	<b>Item/components and probable cause</b>		<b>Check or maintenance job</b>	<b>Reinstatement method</b>
1	Intake air pressure sensor hose		<ul style="list-style-type: none"> <li>• Check the intake air pressure sensor hose condition.</li> <li>• Repair or replace the sensor hose.</li> </ul>	Cranking the engine.
2	Defective intake air pressure sensor.		<ul style="list-style-type: none"> <li>• Execute the diagnostic mode. (Code No. 03)</li> <li>• Replace if defective. Refer to "CHECKING THE INTAKE AIR PRESSURE SENSOR" on page 8-103.</li> </ul>	

<b>Fault code No.</b>	<b>15</b>	<b>Symptom</b>	<b>Throttle position sensor (for throttle valves): open or short circuit detected.</b>	
<b>Diagnostic code No.</b>		<b>01 13</b>	<b>Throttle position sensor (for throttle valves) signal 1 Throttle position sensor (for throttle valves) signal 2</b>	
<b>Order</b>	<b>Item/components and probable cause</b>		<b>Check or maintenance job</b>	<b>Reinstatement method</b>
1	Installed condition of throttle position sensor (for throttle valves).		<ul style="list-style-type: none"> <li>• Check for looseness or pinching.</li> <li>• Check that the sensor is installed in the specified position.</li> </ul>	Turning the main switch to "ON".
2	Connections <ul style="list-style-type: none"> <li>• Throttle position sensor (for throttle valves) coupler</li> <li>• Main wire harness ECU coupler</li> </ul>		<ul style="list-style-type: none"> <li>• Check the coupler for any pins that may be pulled out.</li> <li>• Check the locking condition of the coupler.</li> <li>• If there is a malfunction, repair it and connect the coupler securely.</li> </ul>	
3	Open or short circuit in wire harness.		<ul style="list-style-type: none"> <li>• Repair or replace if there is an open or short circuit.</li> <li>• Between throttle position sensor (for throttle valves) coupler and ECU coupler. (Black/Blue–Black/Blue) (White–White) (Black–Black) (Blue–Blue)</li> </ul>	
4	Defective throttle position sensor (for throttle valves).		<ul style="list-style-type: none"> <li>• Execute the diagnostic mode. (Code Nos. 01, 13)</li> <li>• Replace if defective. Refer to "CHECKING THE THROTTLE POSITION SENSOR (FOR THROTTLE VALVES)" on page 8-101.</li> </ul>	

## FUEL INJECTION SYSTEM

<b>Fault code No.</b>	<b>17</b>	<b>Symptom</b>	<b>EXUP servo motor circuit: open or short circuit detected.</b>	
<b>Diagnostic code No.</b>	<b>53</b>	<b>EXUP servo motor</b>		
<b>Order</b>	<b>Item/components and probable cause</b>	<b>Check or maintenance job</b>	<b>Reinstatement method</b>	
1	Connections <ul style="list-style-type: none"> <li>• EXUP servo motor coupler</li> <li>• Main wire harness ECU coupler</li> </ul>	<ul style="list-style-type: none"> <li>• Check the coupler for any pins that may have pulled out.</li> <li>• Check the locking condition of the coupler.</li> <li>• If there is a malfunction, repair it and connect the coupler securely.</li> </ul>	Reinstated automatically if a normal signal is received.	
2	Open or short circuit in wire harness.	<ul style="list-style-type: none"> <li>• Repair or replace if there is an open or short circuit.</li> <li>• Between EXUP servo motor coupler and ECU coupler. (Blue-Blue) (White/Red-White/Red) (Black/Blue-Black/Blue)</li> </ul>		
3	Defective EXUP servo motor (potentiometer circuit).	<ul style="list-style-type: none"> <li>• Execute the diagnostic mode. (Code No.53)</li> <li>• Replace if defective.</li> </ul>		

<b>Fault code No.</b>	<b>18</b>	<b>Symptom</b>	<b>EXUP servo motor is stuck.</b>	
<b>Diagnostic code No.</b>	<b>53</b>	<b>EXUP servo motor</b>		
<b>Order</b>	<b>Item/components and probable cause</b>	<b>Check or maintenance job</b>	<b>Reinstatement method</b>	
1	Connections <ul style="list-style-type: none"> <li>• EXUP servo motor coupler</li> <li>• Main wire harness ECU coupler</li> </ul>	<ul style="list-style-type: none"> <li>• Check the coupler for any pins that may be pulled out.</li> <li>• Check the locking condition of the couplers.</li> <li>• If there is a malfunction, repair it and connect the coupler securely.</li> </ul>	Turning the main switch to "ON". It takes 3 seconds at the maximum before the original state returns.	
2	Open or short circuit in wire harness.	<ul style="list-style-type: none"> <li>• Repair or replace if there is an open or short circuit.</li> <li>• Between EXUP servo motor coupler and ECU coupler. (Black/Green-Black/Green) (Black/Red-Black/Red)</li> </ul>		
3	Defective EXUP servo motor	<ul style="list-style-type: none"> <li>• Execute the diagnostic mode. (Code No.53)</li> <li>• Replace if defective.</li> </ul>		
4	Defective EXUP valve, pulley, and cables	Replace if defective.		

## FUEL INJECTION SYSTEM

<b>Fault code No.</b>	<b>19</b>	<b>Symptom</b>	<b>Open circuit is detected in the input line from the side-stand switch to the ECU.</b>	
<b>Diagnostic code No.</b>	<b>20</b>	<b>Sidestand switch</b>		
<b>Order</b>	<b>Item/components and probable cause</b>		<b>Check or maintenance job</b>	<b>Reinstatement method</b>
1	Connections • Main wire harness ECU coupler		<ul style="list-style-type: none"> <li>• Execute the diagnostic mode. (Code No.20)</li> <li>• Check the coupler for any pins that may be pulled out.</li> <li>• Check the locking condition of the coupler.</li> <li>• If there is a malfunction, repair it and connect the coupler securely.</li> </ul>	If the transmission is in gear, retracting the sidestand. If the transmission is in neutral, reconnecting the wiring.
2	Open or short circuit in wire harness.		<ul style="list-style-type: none"> <li>• Repair or replace if there is an open or short circuit.</li> <li>• Between ECU coupler and relay unit coupler. (Blue/Yellow–Blue/Yellow)</li> <li>• Between relay unit coupler and sidestand switch coupler. (Blue/Black–Blue/Black)</li> <li>• Between sidestand switch coupler and engine ground. (Black–Black)</li> </ul>	
3	Defective sidestand switch.		<ul style="list-style-type: none"> <li>• Replace if defective. Refer to "CHECKING THE SWITCHES" on page 8-85.</li> </ul>	

<b>Fault code No.</b>	<b>20</b>	<b>Symptom</b>	<b>When the main switch is turned to "ON", the atmospheric pressure sensor voltage and intake air pressure sensor voltage differ greatly.</b>	
<b>Diagnostic code No.</b>	<b>03 02</b>	<b>Intake air pressure sensor Atmospheric pressure sensor</b>		
<b>Order</b>	<b>Item/components and probable cause</b>		<b>Check or maintenance job</b>	<b>Reinstatement method</b>
1	Defective intake air pressure sensor or atmospheric pressure sensor.		<ul style="list-style-type: none"> <li>• Execute the diagnostic mode. (Code Nos. 03, 02) Replace if defective.</li> <li>• Refer to "CHECKING THE INTAKE AIR PRESSURE SENSOR" on page 8-103 or "CHECKING THE ATMOSPHERIC PRESSURE SENSOR" on page 8-102.</li> </ul>	Turning the main switch to "ON".

## FUEL INJECTION SYSTEM

<b>Fault code No.</b>	<b>21</b>	<b>Symptom</b>	<b>Coolant temperature sensor: open or short circuit detected.</b>	
<b>Diagnostic code No.</b>	<b>06</b>	<b>Coolant temperature sensor</b>		
Order	Item/components and probable cause	Check or maintenance job	Reinstatement method	
1	Connections <ul style="list-style-type: none"> <li>• Coolant temperature sensor coupler</li> <li>• Main wire harness ECU coupler</li> </ul>	<ul style="list-style-type: none"> <li>• Check the coupler for any pins that may have pulled out.</li> <li>• Check the locking condition of the couplers.</li> <li>• If there is a malfunction, repair it and connect the coupler securely.</li> </ul>	Reinstated automatically if a normal signal is received.	
2	Open or short circuit in wire harness.	<ul style="list-style-type: none"> <li>• Repair or replace if there is an open or short circuit.</li> <li>• Between coolant temperature sensor coupler and ECU coupler. (Green/White–Green/White) (Black/Blue–Black/Blue)</li> </ul>		
3	Defective coolant temperature sensor.	<ul style="list-style-type: none"> <li>• Execute the diagnostic mode. (Code No.06)</li> <li>• Replace if defective. Refer to "CHECKING THE COOLANT TEMPERATURE SENSOR" on page 8-100.</li> </ul>		

<b>Fault code No.</b>	<b>22</b>	<b>Symptom</b>	<b>Air temperature sensor: open or short circuit detected.</b>	
<b>Diagnostic code No.</b>	<b>05</b>	<b>Air temperature sensor</b>		
Order	Item/components and probable cause	Check or maintenance job	Reinstatement method	
1	Connections <ul style="list-style-type: none"> <li>• Air temperature sensor coupler</li> <li>• Main wire harness ECU coupler</li> </ul>	<ul style="list-style-type: none"> <li>• Check the coupler for any pins that may have pulled out.</li> <li>• Check the locking condition of the coupler.</li> <li>• If there is a malfunction, repair it and connect the coupler securely.</li> </ul>	Reinstated automatically if a normal signal is received.	
2	Open or short circuit in wire harness.	<ul style="list-style-type: none"> <li>• Repair or replace if there is an open or short circuit.</li> <li>• Between air temperature sensor coupler and ECU coupler. (Brown/White–Brown/White) (Black/Blue–Black/Blue)</li> </ul>		
3	Defective air temperature sensor.	<ul style="list-style-type: none"> <li>• Execute the diagnostic mode. (Code No.05)</li> <li>• Replace if defective. Refer to "CHECKING THE INTAKE AIR TEMPERATURE SENSOR" on page 8-103.</li> </ul>		

## FUEL INJECTION SYSTEM

<b>Fault code No.</b>	<b>23</b>	<b>Symptom</b>	<b>Atmospheric pressure sensor: open or short circuit detected.</b>	
<b>Diagnostic code No.</b>	<b>02</b>	<b>Atmospheric pressure sensor</b>		
Order	Item/components and probable cause	Check or maintenance job	Reinstatement method	
1	Connections <ul style="list-style-type: none"> <li>• Atmospheric pressure sensor coupler</li> <li>• Main wire harness ECU coupler</li> </ul>	<ul style="list-style-type: none"> <li>• Check the coupler for any pins that may have pulled out.</li> <li>• Check the locking condition of the coupler.</li> <li>• If there is a malfunction, repair it and connect the coupler securely.</li> </ul>	Reinstated automatically if a normal signal is received.	
2	Open or short circuit in wire harness and/or sub wire harness 2.	<ul style="list-style-type: none"> <li>• Repair or replace if there is an open or short circuit.</li> <li>• Between atmospheric pressure sensor coupler and ECU coupler. (Black/Blue–Black/Blue) (Pink–Pink) (Blue–Blue)</li> </ul>		
3	Defective atmospheric pressure sensor.	<ul style="list-style-type: none"> <li>• Execute the diagnostic mode. (Code No.02)</li> <li>• Replace if defective. Refer to "CHECKING THE ATMOSPHERIC PRESSURE SENSOR" on page 8-102.</li> </ul>		

<b>Fault code No.</b>	<b>24</b>	<b>Symptom</b>	<b>No normal signal is received from the O<sub>2</sub> sensor.</b>	
<b>Diagnostic code No.</b>	<b>—</b>	<b>—</b>		
Order	Item/components and probable cause	Check or maintenance job	Reinstatement method	
1	Installed state of O <sub>2</sub> sensor.	Check for looseness or pinching.	Execute the diagnostic mode (Code No. 63). (Set the engine stop switch to “○”.)	
2	Connections <ul style="list-style-type: none"> <li>• O<sub>2</sub> sensor coupler</li> <li>• Main wire harness ECU coupler</li> </ul>	<ul style="list-style-type: none"> <li>• Check the couplers for any pins that may be pulled out.</li> <li>• Check the locking condition of the couplers.</li> <li>• If there is a malfunction, repair it and connect the coupler securely.</li> </ul>		
3	Open or short circuit in wire harness.	<ul style="list-style-type: none"> <li>• Repair or replace if there is an open or short circuit.</li> <li>• Between O<sub>2</sub> sensor coupler and ECU coupler. (Gray/Green–Gray/Green) (Black/Blue–Black/Blue)</li> </ul>		
4	Check fuel pressure.	• Refer to "THROTTLE BODIES" on page 7-4.		
5	Defective O <sub>2</sub> sensor.	• Replace if defective.		

## FUEL INJECTION SYSTEM

<b>Fault code No.</b>	<b>30</b>	<b>Symptom</b>	<b>Latch up detected. No normal signal is received from the lean angle sensor.</b>	
<b>Diagnostic code No.</b>	<b>08</b>	<b>Lean angle sensor</b>		
<b>Order</b>	<b>Item/components and probable cause</b>	<b>Check or maintenance job</b>	<b>Reinstatement method</b>	
1	The vehicle has overturned.	Raise the vehicle upright.	Turning the main switch to "ON" (however, the engine cannot be restarted unless the main switch is first turned to "OFF").	
2	Installed state of the lean angle sensor.	Check the installed direction and condition of the sensor.		
3	Defective lean angle sensor.	<ul style="list-style-type: none"> <li>• Execute the diagnostic mode. (Code No.08)</li> <li>• Replace if defective. Refer to "CHECKING THE LEAN ANGLE SENSOR" on page 8-96.</li> </ul>		

<b>Fault code No.</b>	<b>33</b>	<b>Symptom</b>	<b>Open circuit detected in the primary lead of the cylinder-#1 ignition coil.</b>	
<b>Diagnostic code No.</b>	<b>30</b>	<b>Cylinder-#1 ignition coil</b>		
<b>Order</b>	<b>Item/components and probable cause</b>	<b>Check or maintenance job</b>	<b>Reinstatement method</b>	
1	Connections <ul style="list-style-type: none"> <li>• Cylinder-#1 ignition coil coupler</li> <li>• Main wire harness ECU coupler</li> <li>• Sub-wire harness 1 coupler</li> </ul>	<ul style="list-style-type: none"> <li>• Check the coupler for any pins that may be pulled out.</li> <li>• Check the locking condition of the coupler.</li> <li>• If there is a malfunction, repair it and connect coupler securely.</li> </ul>	Cranking the engine. (Connect the cylinder-#1 ignition coil coupler.)	
2	Open or short circuit in wire harness and/or sub-wire harness 1.	<ul style="list-style-type: none"> <li>• Repair or replace if there is an open or short circuit.</li> <li>• Between cylinder-#1 ignition coil coupler and ECU coupler. (Red/Black–Red/Black) (Orange–Orange)</li> </ul>		
3	Defective cylinder-#1 ignition coil.	<ul style="list-style-type: none"> <li>• Execute the diagnostic mode. (Code No.30)</li> <li>• Test the primary and secondary coils for continuity.</li> <li>• Replace if defective. Refer to "CHECKING THE IGNITION COILS" on page 8-95.</li> </ul>		

## FUEL INJECTION SYSTEM

<b>Fault code No.</b>	<b>34</b>	<b>Symptom</b>	<b>Open circuit detected in the primary lead of the cylinder-#2 ignition coil.</b>	
<b>Diagnostic code No.</b>	<b>31</b>	<b>Cylinder-#2 ignition coil</b>		
<b>Order</b>	<b>Item/components and probable cause</b>	<b>Check or maintenance job</b>	<b>Reinstatement method</b>	
1	Connections <ul style="list-style-type: none"> <li>• Cylinder-#2 ignition coil coupler</li> <li>• Main wire harness ECU coupler</li> <li>• Sub-wire harness 1 coupler</li> </ul>	<ul style="list-style-type: none"> <li>• Check the couplers for any pins that may be pulled out.</li> <li>• Check the locking condition of the couplers.</li> <li>• If there is a malfunction, repair it and connect the coupler securely.</li> </ul>	Cranking the engine. (Connect the cylinder-#2 ignition coil coupler.)	
2	Open or short circuit in wire harness and/or sub-wire harness 1.	<ul style="list-style-type: none"> <li>• Repair or replace if there is an open or short circuit.</li> <li>• Between cylinder-#2 ignition coil coupler and ECU coupler.                          (Red/Black–Red/Black)                          (Gray/Red–Gray/Red)</li> </ul>		
3	Defective cylinder-#2 ignition coil.	<ul style="list-style-type: none"> <li>• Execute the diagnostic mode. (Code No.31)</li> <li>• Test the primary and secondary coils for continuity.</li> <li>• Replace if defective.                          Refer to "CHECKING THE IGNITION COILS" on page 8-95.</li> </ul>		

## FUEL INJECTION SYSTEM

<b>Fault code No.</b>	<b>35</b>	<b>Symptom</b>	<b>Open circuit detected in the primary lead of the cylinder-#3 ignition coil.</b>	
<b>Diagnostic code No.</b>	<b>32</b>	<b>Cylinder-#3 ignition coil</b>		
<b>Order</b>	<b>Item/components and probable cause</b>	<b>Check or maintenance job</b>	<b>Reinstatement method</b>	
1	Connections <ul style="list-style-type: none"> <li>• Cylinder-#3 ignition coil coupler</li> <li>• Main wire harness ECU coupler</li> <li>• Sub-wire harness 1 coupler</li> </ul>	<ul style="list-style-type: none"> <li>• Check the couplers for any pins that may have pulled out.</li> <li>• Check the locking condition of the couplers.</li> <li>• If there is a malfunction, repair it and connect the coupler securely.</li> </ul>	Cranking the engine. (Connect the cylinder-#3 ignition coil coupler.)	
2	Open or short circuit in wire harness and/or sub-wire harness 1.	<ul style="list-style-type: none"> <li>• Repair or replace if there is an open or short circuit.</li> <li>• Between cylinder-#3 ignition coil coupler and ECU coupler.                          (Red/Black–Red/Black)                          (Orange/Green–Orange/Green)</li> </ul>		
3	Defective cylinder-#3 ignition coil.	<ul style="list-style-type: none"> <li>• Execute the diagnostic mode. (Code No.32)</li> <li>• Test the primary and secondary coils for continuity.</li> <li>• Replace if defective.                          Refer to "CHECKING THE IGNITION COILS" on page 8-95.</li> </ul>		

## FUEL INJECTION SYSTEM

<b>Fault code No.</b>	<b>36</b>	<b>Symptom</b>	<b>Open circuit detected in the primary lead of the cylinder-#4 ignition coil.</b>	
<b>Diagnostic code No.</b>	<b>33</b>	<b>Cylinder-#4 ignition coil</b>		
<b>Order</b>	<b>Item/components and probable cause</b>	<b>Check or maintenance job</b>	<b>Reinstatement method</b>	
1	Connections <ul style="list-style-type: none"> <li>• Cylinder-#4 ignition coil coupler</li> <li>• Main wire harness ECU coupler</li> <li>• Sub-wire harness 1 coupler</li> </ul>	<ul style="list-style-type: none"> <li>• Check the couplers for any pins that may have pulled out.</li> <li>• Check the locking condition of the couplers.</li> <li>• If there is a malfunction, repair it and connect the coupler securely.</li> </ul>	Cranking the engine. (Connect the cylinder-#4 ignition coil coupler.)	
2	Open or short circuit in wire harness and/or sub-wire harness 1.	<ul style="list-style-type: none"> <li>• Repair or replace if there is an open or short circuit.</li> <li>• Between cylinder-#4 ignition coil coupler and ECU coupler/main wire harness.                          (Red/Black–Red/Black)                          (Gray/Green–Gray/Green)</li> </ul>		
3	Defective cylinder-#4 ignition coil.	<ul style="list-style-type: none"> <li>• Execute the diagnostic mode. (Code No.33)</li> <li>• Test the primary and secondary coils for continuity.</li> <li>• Replace if defective.                          Refer to "CHECKING THE IGNITION COILS" on page 8-95.</li> </ul>		

## FUEL INJECTION SYSTEM

Fault code No.	39	Symptom	Open circuit detected in injector.
Diagnostic code No.		36 37 38 39	Injector #1 Injector #2 Injector #3 Injector #4
Order		Item/components and probable cause	Check or maintenance job
1		Connections <ul style="list-style-type: none"> <li>• Injector coupler</li> <li>• Main wire harness ECU coupler</li> <li>• Sub-wire harness 2 coupler</li> </ul>	<ul style="list-style-type: none"> <li>• Check the couplers for any pins that may have pulled out.</li> <li>• Check the locking condition of the couplers.</li> <li>• If there is a malfunction, repair it and connect the coupler securely.</li> </ul>
2		Open or short circuit in wire harness and/or sub-wire harness 2.	<ul style="list-style-type: none"> <li>• Repair or replace if there is an open or short circuit.</li> <li>• Between injector coupler and ECU coupler.                      (Red/Blue–Red/Blue)                      #1: (Red/Black–Red/Black)                      #2: (Green/Black–Green/Black)                      #3: (Blue/Black–Blue/Black)                      #4: (Orange/Black–Orange/Black)</li> </ul>
3		Defective injector.	<ul style="list-style-type: none"> <li>• Execute the diagnostic mode. (Code Nos.36, 37, 38, 39)</li> <li>• Replace if defective. Refer to "CHECKING THE INJECTORS" on page 7-6.</li> </ul>

## FUEL INJECTION SYSTEM

<b>Fault code No.</b>	<b>41</b>	<b>Symptom</b>	<b>Lean angle sensor: open or short circuit detected.</b>	
<b>Diagnostic code No.</b>	<b>08</b>	<b>Lean angle sensor</b>		
Order	Item/components and probable cause	Check or maintenance job	Reinstatement method	
1	Connections <ul style="list-style-type: none"> <li>• Lean angle sensor coupler</li> <li>• Main wire harness ECU coupler</li> </ul>	<ul style="list-style-type: none"> <li>• Check the coupler for any pins that may be pulled out.</li> <li>• Check the locking condition of the coupler.</li> <li>• If there is a malfunction, repair it and connect the coupler securely.</li> </ul>	Reinstated automatically if a normal signal is received.	
2	Open or short circuit in lead wire.	<ul style="list-style-type: none"> <li>• Repair or replace if there is an open or short circuit.</li> <li>• Between lean angle sensor coupler and ECU coupler. (Blue-Blue) (Yellow/Green-Yellow/Green) (Black/Blue-Black/Blue)</li> </ul>		
3	Defective lean angle sensor.	<ul style="list-style-type: none"> <li>• Execute the diagnostic mode. (Code No.08)</li> <li>• Replace if defective. Refer to "CHECKING THE LEAN ANGLE SENSOR" on page 8-96.</li> </ul>		

## FUEL INJECTION SYSTEM

<b>Fault code No.</b>	42	<b>Symptom</b>	<b>A</b> No normal signals are received from the speed sensor. <b>B</b> Open circuit is detected in the neutral switch.	
<b>Diagnostic code No.</b>	<b>A</b>	07	<b>Speed sensor</b>	
	<b>B</b>	21	<b>Neutral switch</b>	
<b>Order</b>	<b>Item/components and probable cause</b>		<b>Check or maintenance job</b>	<b>Reinstatement method</b>
A-1	Installed state of speed sensor.		Check for looseness or pinching.	Starting the engine, and activating the speed sensor by operating the vehicle.
A-2	Connections <ul style="list-style-type: none"> <li>• Speed sensor coupler</li> <li>• Main wire harness ECU coupler</li> </ul>		<ul style="list-style-type: none"> <li>• Check the couplers for any pins that may be pulled out.</li> <li>• Check the locking condition of the couplers.</li> <li>• If there is a malfunction, repair it and connect the coupler securely.</li> </ul>	
A-3	Open or short circuit in lead.		<ul style="list-style-type: none"> <li>• Repair or replace if there is an open or short circuit.</li> <li>• Between speed sensor coupler and ECU coupler. (Blue–Blue) (White/Yellow–White/Yellow) (Black/Blue–Black/Blue)</li> </ul>	
A-4	Defective speed sensor.		<ul style="list-style-type: none"> <li>• Execute the diagnostic mode. (Code No. 07)</li> <li>• Replace if defective. Refer to "CHECKING THE SPEED SENSOR" on page 8-99.</li> </ul>	
B-1	Installed state of neutral switch.		Check for looseness or pinching.	
B-2	Connections <ul style="list-style-type: none"> <li>• Neutral switch coupler</li> <li>• Main wire harness ECU coupler</li> </ul>		<ul style="list-style-type: none"> <li>• Check the couplers for any pins that may be pulled out.</li> <li>• Check the locking condition of the couplers.</li> <li>• If there is a malfunction, repair it and connect the coupler securely.</li> </ul>	
B-3	Open circuit in neutral switch lead.		<ul style="list-style-type: none"> <li>• Repair or replace if there is an open circuit.</li> <li>• Between neutral switch coupler and relay unit coupler. (Sky blue–Sky blue)</li> <li>• Between relay unit coupler and ECU coupler. (Blue/Yellow–Blue/Yellow)</li> </ul>	
B-4	Defective neutral switch.		<ul style="list-style-type: none"> <li>• Execute the diagnostic mode. (Code No.21)</li> <li>• Replace if defective. Refer to "CHECKING THE SWITCHES" on page 8-85.</li> </ul>	
B-5	Faulty shift drum (neutral detection area).		<ul style="list-style-type: none"> <li>• Replace if defective. Refer to "TRANSMISSION" on page 5-84.</li> </ul>	

## FUEL INJECTION SYSTEM

<b>Fault code No.</b>	<b>43</b>	<b>Symptom</b>	<b>Power supply to the injectors and fuel pump is not normal.</b>	
<b>Diagnostic code No.</b>	<b>09</b>	<b>Fuel system voltage (battery voltage)</b>		
<b>Order</b>	<b>Item/components and probable cause</b>	<b>Check or maintenance job</b>	<b>Reinstatement method</b>	
1	Connections <ul style="list-style-type: none"> <li>• Relay unit coupler (fuel pump relay)</li> <li>• Main wire harness ECU coupler</li> </ul>	<ul style="list-style-type: none"> <li>• Check the coupler for any pins that may have pulled out.</li> <li>• Check the locking condition of the coupler.</li> <li>• If there is a malfunction, repair it and connect the coupler securely.</li> </ul>	Turning the main switch to "ON" when the engine stop switch is set to "○".	
2	Open or short circuit in the wire harness.	<ul style="list-style-type: none"> <li>• Repair or replace if there is an open or short circuit.</li> <li>• Between relay unit coupler and ECU coupler. (Blue/Yellow–Blue/Yellow) (Red/Blue–Red/Blue)</li> <li>• Between relay unit coupler and starter relay coupler. (Red–Red)</li> <li>• Between relay unit coupler and right handlebar switch coupler. (Red/Black–Red/Black)</li> </ul>		
3	Malfunction or open circuit in fuel pump relay.	<ul style="list-style-type: none"> <li>• Execute the diagnostic mode. (Code No. 09)</li> <li>• Replace if defective.</li> <li>• If there is no malfunction with the fuel pump relay, replace the ECU.</li> </ul>		

## FUEL INJECTION SYSTEM

<b>Fault code No.</b>	<b>44</b>	<b>Symptom</b>	<b>An error is detected while reading or writing on EEPROM (CO adjustment value).</b>	
<b>Diagnostic code No.</b>	<b>60</b>	<b>EEPROM fault cylinder No.</b>		
Order	Item/components and probable cause	Check or maintenance job	Reinstatement method	
1	Malfunction in ECU.	<ul style="list-style-type: none"> <li>• Set the faulty cylinder's exhaust gas volume.</li> <li>1 Execute the diagnostic mode (Code No. 60) to check the faulty cylinder number. (If multiple cylinders are defective, the numbers of the faulty cylinders are displayed alternately at 2-second intervals.)</li> <li>2 Execute the CO adjustment mode and set the exhaust gas volume of the faulty cylinder to "0".</li> <li>Refer to "ADJUSTING THE EXHAUST GAS VOLUME" on page 3-8.</li> <li>• Replace ECU if it does not recover from the malfunction.</li> </ul>	Turning the main switch to "ON". (Readjust the exhaust gas volume after it is reinstated.)	

<b>Fault code No.</b>	<b>46</b>	<b>Symptom</b>	<b>Power supply is not normal.</b>	
<b>Diagnostic code No.</b>	—	—		
Order	Item/components and probable cause	Check or maintenance job	Reinstatement method	
1	Malfunction in rectifier/regulator	<ul style="list-style-type: none"> <li>• Replace if defective.</li> <li>Refer to "CHARGING SYSTEM" on page 8-11.</li> </ul>	Starting the engine and operating it at idle.	
2	Open or short circuit in wire harness.	<ul style="list-style-type: none"> <li>• Repair or replace if there is an open or short circuit in the charging system's wiring.</li> <li>Refer to "CHARGING SYSTEM" on page 8-11.</li> </ul>		

<b>Fault code No.</b>	<b>50</b>	<b>Symptom</b>	<b>Faulty ECU memory. (When this malfunction is detected in the ECU, the fault code number might not appear on the meter.)</b>	
<b>Diagnostic code No.</b>	—	—		
Order	Item/components and probable cause	Check or maintenance job	Reinstatement method	
1	Malfunction in ECU.	Replace the ECU.  <b>NOTE:</b> _____ Be sure to turn the main switch to "OFF" before replacing the ECU.	Turning the main switch to "ON".	

## FUEL INJECTION SYSTEM

<b>Fault code No.</b>	59	<b>Symptom</b>	<b>Throttle position sensor (for throttle cable pulley): open or short circuit detected.</b> <b>Throttle position sensor (for throttle cable pulley): coupler connection is loose.</b>	
<b>Diagnostic code No.</b>	14 15	<b>Throttle position sensor (for throttle cable pulley) signal 1</b> <b>Throttle position sensor (for throttle cable pulley) signal 2</b>		
<b>Order</b>	<b>Item/components and probable cause</b>		<b>Check or maintenance job</b>	<b>Reinstatement method</b>
1	Installed state of throttle position sensor (for throttle cable pulley).		<ul style="list-style-type: none"> <li>• Check for looseness or pinching.</li> <li>• Check that the sensor is installed in the specified position.</li> </ul>	Turning the main switch to "ON".
2	<b>Connections</b> <ul style="list-style-type: none"> <li>• Throttle position sensor (for throttle cable pulley) coupler</li> <li>• Main wire harness ECU coupler</li> </ul>		<ul style="list-style-type: none"> <li>• Check the couplers for any pins that may be pulled out.</li> <li>• Check the locking condition of the couplers.</li> <li>• If there is a malfunction, repair it and connect the coupler securely.</li> </ul>	
3	Open or short circuit in wire harness.		<ul style="list-style-type: none"> <li>• Repair or replace if there is an open or short circuit.</li> <li>• Between throttle position sensor (for throttle cable pulley) coupler and ECU coupler. (Black/Blue–Black/Blue) (White–White) (Blue–Blue) (Black–Black)</li> </ul>	
4	Defective throttle position sensor (for throttle cable pulley).		<ul style="list-style-type: none"> <li>• Execute the diagnostic mode. (Code Nos. 14, 15)</li> <li>• Replace if defective. Refer to "CHECKING THE THROTTLE POSITION SENSOR (FOR THROTTLE CABLE PULLEY)" on page 8-101.</li> </ul>	

## FUEL INJECTION SYSTEM

<b>Fault code No.</b>	<b>60</b>	<b>Symptom</b>	<b>Throttle servo motor: open or short circuit detected. Defective throttle servo motor. Malfunction in ECU (servo motor driving system).</b>	
<b>Diagnostic code No.</b>	<b>01 13</b>	<b>Throttle position sensor (for throttle valves) signal 1 Throttle position sensor (for throttle valves) signal 2</b>		
Order	Item/components and probable cause	Check or maintenance job	Reinstatement method	
1	Installed state of throttle position sensor (for throttle valves).	<ul style="list-style-type: none"> <li>• Check for looseness or pinching.</li> <li>• Check that the sensor is installed in the specified position.</li> </ul>	Turning the main switch to "ON".	
2	Connections <ul style="list-style-type: none"> <li>• Throttle servo motor coupler</li> <li>• Main wire harness ECU coupler</li> </ul>	<ul style="list-style-type: none"> <li>• Check the couplers for any pins that may be pulled out.</li> <li>• Check the locking condition of the couplers.</li> <li>• If there is a malfunction, repair it and connect the coupler securely.</li> </ul>		
3	Open or short circuit in wire harness.	<ul style="list-style-type: none"> <li>• Repair or replace if there is an open or short circuit.</li> <li>• Between throttle servo motor coupler and ECU coupler. (Yellow/Red–Yellow/Red) (Light green/Red–Light green/Red)</li> </ul>		
4	Defective throttle servo motor.	<ul style="list-style-type: none"> <li>• Execute the diagnostic mode. (Code Nos. 01, 13)</li> <li>• Replace the throttle body assembly if defective.</li> </ul>		
5	Malfunction in ECU.	Replace the ECU.		

<b>Fault code No.</b>	<b>Er-1</b>	<b>Symptom</b>	<b>No signals are received from the ECU.</b>	
<b>Diagnostic code No.</b>	—	—		
Order	Item/components and probable cause	Check or maintenance job	Reinstatement method	
1	Connections <ul style="list-style-type: none"> <li>• Main wire harness ECU coupler</li> <li>• Main wire harness meter assembly coupler</li> </ul>	<ul style="list-style-type: none"> <li>• Check the couplers for any pins that may be pulled out.</li> <li>• Check the locking condition of the coupler.</li> <li>• If there is a malfunction, repair it and connect the coupler securely.</li> </ul>	Turning the main switch to "ON".	
2	Open or short circuit in wire harness.	<ul style="list-style-type: none"> <li>• Repair or replace if there is an open or short circuit.</li> <li>• Between meter assembly coupler and ECU coupler. (Yellow/Blue–Yellow/Blue)</li> </ul>		
3	Malfunction in meter assembly.	Replace the meter assembly.		
4	Malfunction in ECU.	Replace the ECU.		

## FUEL INJECTION SYSTEM

Fault code No.	Er-2	Symptom	No signals are received from the ECU within the specified duration.	
Diagnostic code No.		—	—	
Order	Item/components and probable cause		Check or maintenance job	Reinstatement method
1	Connections <ul style="list-style-type: none"> <li>• Main wire harness ECU coupler</li> <li>• Main wire harness meter assembly coupler</li> </ul>		<ul style="list-style-type: none"> <li>• Check the coupler for any pins that may be pulled out.</li> <li>• Check the locking condition of the coupler.</li> <li>• If there is a malfunction, repair it and connect the coupler securely.</li> </ul>	Turning the main switch to "ON".
2	Open or short circuit in wire harness.		<ul style="list-style-type: none"> <li>• Repair or replace if there is an open or short circuit.</li> <li>• Between meter assembly coupler and ECU coupler. (Yellow/Blue–Yellow/Blue)</li> </ul>	
3	Malfunction in meter assembly.		Replace the meter assembly.	
4	Malfunction in ECU.		Replace the ECU.	

Fault code No.	Er-3	Symptom	Data from the ECU cannot be received correctly.	
Diagnostic code No.		—	—	
Order	Item/components and probable cause		Check or maintenance job	Reinstatement method
1	Connections <ul style="list-style-type: none"> <li>• Main wire harness ECU coupler</li> <li>• Main wire harness meter assembly coupler</li> </ul>		<ul style="list-style-type: none"> <li>• Check the couplers for any pins that may be pulled out.</li> <li>• Check the locking condition of the coupler.</li> <li>• If there is a malfunction, repair it and connect the coupler securely.</li> </ul>	Turning the main switch to "ON".
2	Open or short circuit in wire harness.		<ul style="list-style-type: none"> <li>• Repair or replace if there is an open or short circuit.</li> <li>• Between meter assembly coupler and ECU coupler. (Yellow/Blue–Yellow/Blue)</li> </ul>	
3	Malfunction in meter assembly.		Replace the meter assembly.	
4	Malfunction in ECU.		Replace the ECU.	

**FUEL INJECTION SYSTEM**

<b>Fault code No.</b>	<b>Er-4</b>	<b>Symptom</b>	<b>Non-registered data has been received from the meter.</b>	
<b>Diagnostic code No.</b>	—	—		
<b>Order</b>	<b>Item/components and probable cause</b>	<b>Check or maintenance job</b>	<b>Reinstatement method</b>	
1	Connections <ul style="list-style-type: none"> <li>• Main wire harness ECU coupler</li> <li>• Main wire harness meter assembly coupler</li> </ul>	<ul style="list-style-type: none"> <li>• Check the couplers for any pins that may be pulled out.</li> <li>• Check the locking condition of the coupler.</li> <li>• If there is a malfunction, repair it and connect the coupler securely.</li> </ul>	Turning the main switch to "ON".	
2	Open or short circuit in wire harness.	<ul style="list-style-type: none"> <li>• Repair or replace if there is an open or short circuit.</li> <li>• Between meter assembly coupler and ECU coupler. (Yellow/Blue–Yellow/Blue)</li> </ul>		
3	Malfunction in meter assembly.	Replace the meter assembly.		
4	Malfunction in ECU	Replace the ECU.		

## **FUEL INJECTION SYSTEM**

---

# FUEL PUMP SYSTEM

EAS27550

## FUEL PUMP SYSTEM

EAS27560

## CIRCUIT DIAGRAM

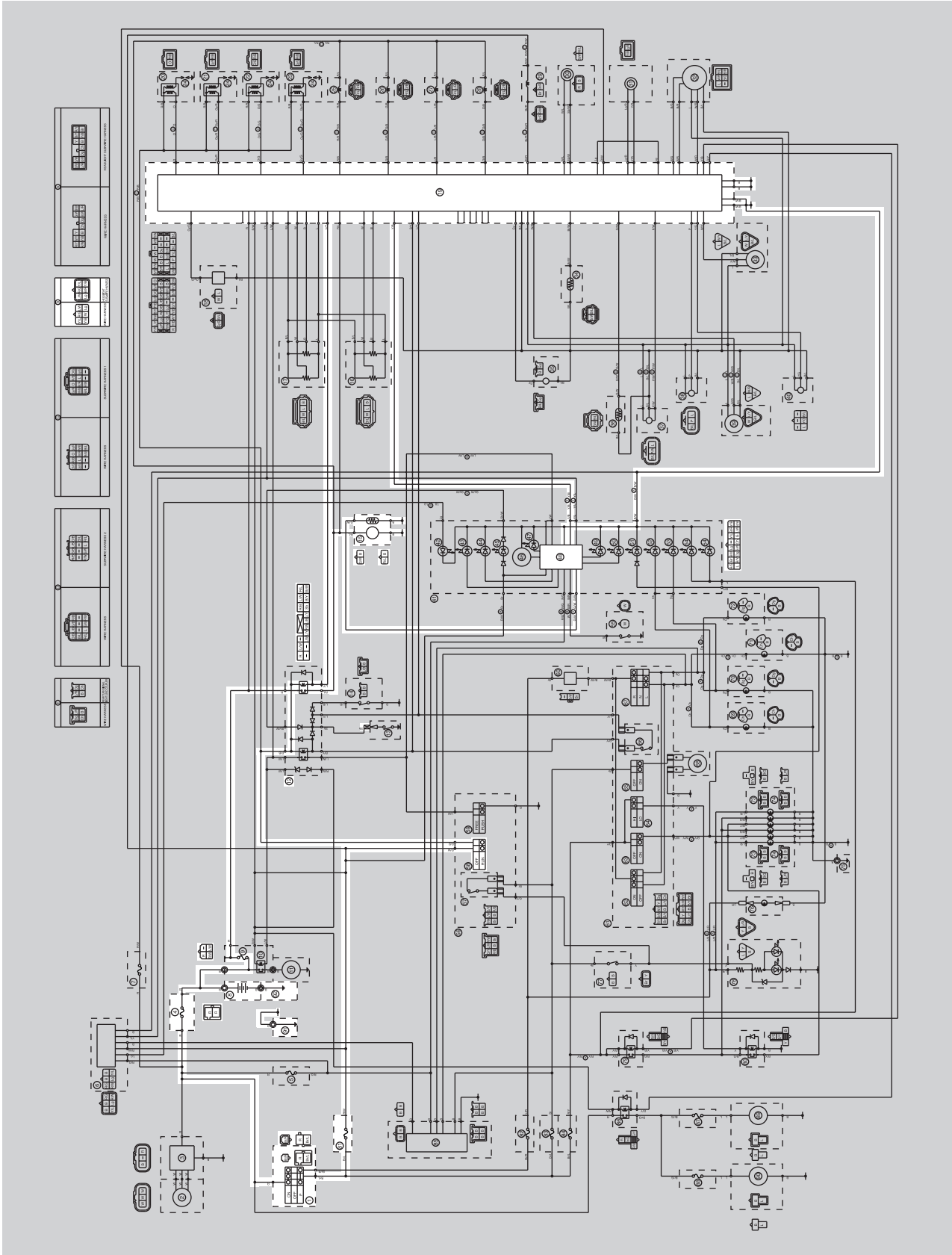

## **FUEL PUMP SYSTEM**

---

- 1. Main switch
- 4. Main fuse
- 8. Battery
- 9. Fuel injection system fuse
- 12. Starting circuit cut-off relay
- 15. Fuel pump
- 19. ECU (engine control unit)
- 48. Multi-function meter
- 58. Engine stop switch
- 81. Ignition fuse
- 91. Ground
- 92. Battery negative lead

## FUEL PUMP SYSTEM

EAS27570

### TROUBLESHOOTING

If the fuel pump fails to operate.

**NOTE:**

- Before troubleshooting, remove the following part(s):

- 1 Rider seat
- 2 Passenger seat
- 3 Fuel tank
- 4 Side cowlings

<p>1 Check the fuses. (Main, ignition and fuel injection system) Refer to "CHECKING THE FUSES" on page 8-89.</p>	NG→	<p>Replace the fuse(s).</p>
OK↓		
<p>2 Check the battery. Refer to "CHECKING AND CHARGING THE BATTERY" on page 8-89.</p>	NG→	<ul style="list-style-type: none"> <li>• Clean the battery terminals.</li> <li>• Recharge or replace the battery.</li> </ul>
OK↓		
<p>3 Check the main switch. Refer to "CHECKING THE SWITCHES" on page 8-85.</p>	NG→	<p>Replace the immobilizer unit.</p>
OK↓		
<p>4 Check the engine stop switch. Refer to "CHECKING THE SWITCHES" on page 8-85.</p>	NG→	<p>Replace the right handlebar switch.</p>
OK↓		
<p>5 Check the starting circuit cut-off relay. Refer to "CHECKING THE RELAYS" on page 8-92.</p>	NG→	<p>Replace the starting circuit cut-off relay.</p>
OK↓		
<p>6 Check the fuel pump. Refer to "CHECKING THE FUEL PRESSURE" on page 7-6.</p>	NG→	<p>Replace the fuel pump.</p>
OK↓		

## FUEL PUMP SYSTEM

---

7 Check the entire fuel pump system's wiring.  
Refer to "FUEL PUMP SYSTEM" on page 8-67.

OK↓

Replace the ECU.

NG→

Properly connect or repair the fuel pump system's wiring.

# IMMOBILIZER SYSTEM

EAS27640

## IMMOBILIZER SYSTEM

EAS27650

## CIRCUIT DIAGRAM

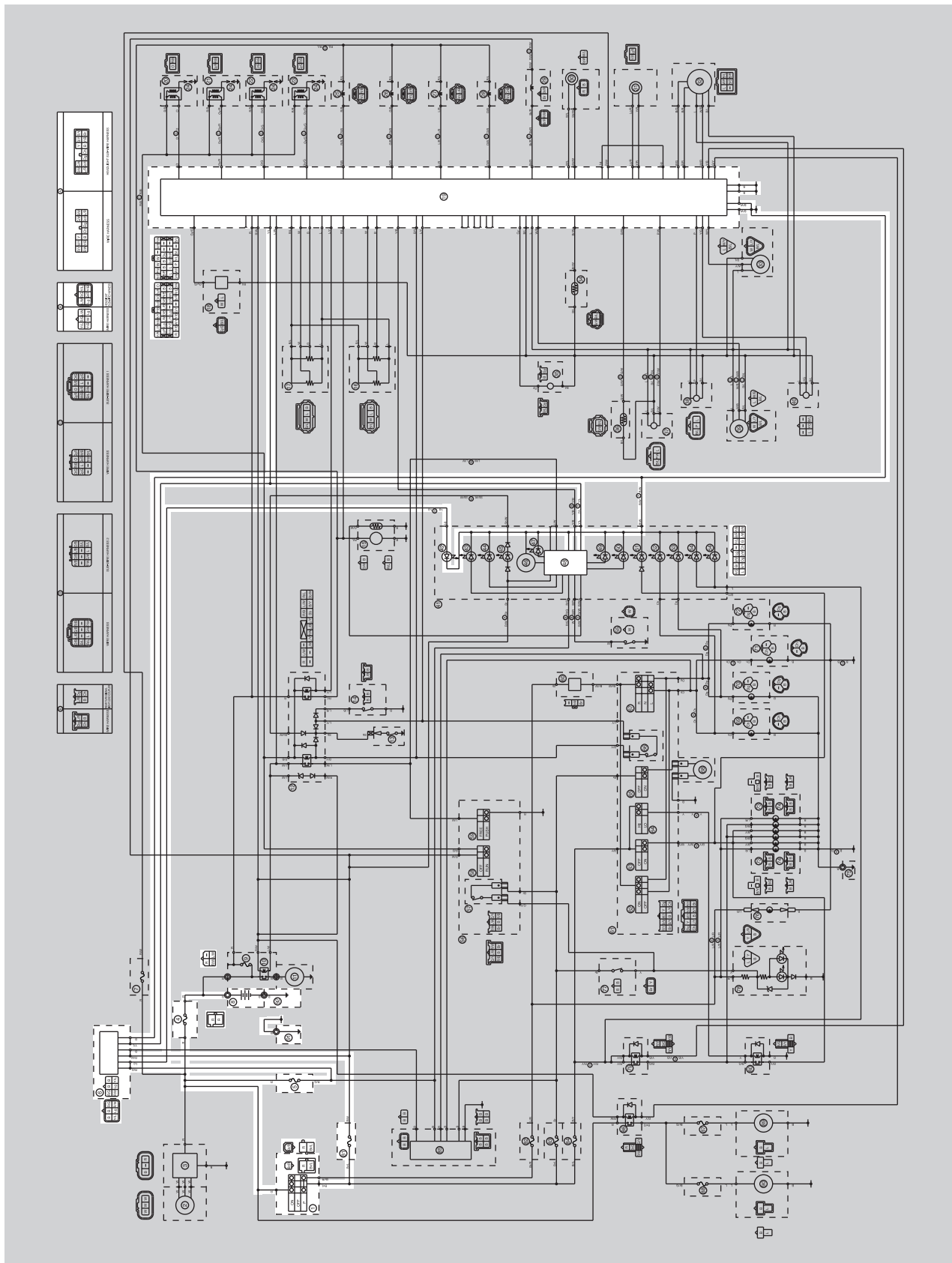

## IMMOBILIZER SYSTEM

---

- 1. Main switch
- 4. Main fuse
- 5. Backup fuse
- 6. Immobilizer unit
- 8. Battery
- 19. ECU (engine control unit)
- 42. Immobilizer system indicator light
- 48. Multi-function meter
- 91. Ground
- 92. Battery negative lead

## IMMOBILIZER SYSTEM

---

EAS27671

### GENERAL INFORMATION

This vehicle is equipped with an immobilizer system to help prevent theft by re-registering codes in the standard keys. This system consists of the following:

- a code re-registering key (with a red bow)
- two standard keys (with a black bow) that can be re-registered with new codes
- a transponder (installed in the key bow)
- an immobilizer unit
- the ECU
- an immobilizer system indicator light

The key with the red bow is used to register codes in each standard key. Do not use the key with the red bow for driving. It should only be used for re-registering new codes in the standard keys. The immobilizer system cannot be operated with a new key until the key registered with a code. If you lose the code re-registering key, the ECU and main switch (equipped with the immobilizer unit) need to be replaced.

Therefore, always use a standard key for driving. (See caution below.)

### NOTE:

Each standard key is registered during production, therefore re-registering at purchase is not necessary.

---

ECA14971

### CAUTION:

- **DO NOT LOSE THE CODE RE-REGISTERING KEY!** If the code re-registering key is lost, registering new codes in the standard keys is impossible. The standard keys can still be used to start the vehicle. However, if code re-registering is required (e.g., if a new standard key is made or all keys are lost) the entire immobilizer system must be replaced. Therefore, it is highly recommended to use either standard key for driving, and to keep the code re-registering key in a safe place.
  - Do not submerge the keys in water.
  - Do not expose the keys to excessively high temperatures.
  - Do not place the keys close to magnets (this includes, but is not limited to, products such as speakers, etc.).
  - Do not place heavy items on the keys.
  - Do not grind the keys or alter their shape.
  - Do not disassemble the key bows.
  - Do not put two keys of any immobilizer system on the same key ring.
  - Keep the standard keys as well as other immobilizer system keys away from the code re-registering key.
  - Keep other immobilizer system keys away from the main switch as they may cause signal interference.
-

## IMMOBILIZER SYSTEM

EAS27691

### PART REPLACEMENT AND KEY CODE REGISTRATION REQUIREMENTS

In the course of use, you may encounter the following cases where replacement of parts and registration of code re-registering/standard keys are required.

**NOTE:**

Each standard key is registered during production, therefore re-registering at purchase is not necessary.

	Parts to be replaced					Key registration requirement
	Main switch/immobilizer unit		Standard key	ECU	Accessory lock* and key	
	Main switch	Immobilizer unit				
Standard key is lost			√			New standard key
All keys have been lost (including code re-registering key)		√	√	√	√	Code re-registering key and standard keys
ECU is defective				√		Code re-registering key and standard keys
Immobilizer unit is defective		√				Code re-registering key and standard keys
Main switch is defective		√	√	√	√	Code re-registering key and standard keys
Accessory lock* is defective					√	Not required

\* Accessory locks mean the seat lock and fuel tank cap.

**Code re-registering key registration:**

When the immobilizer unit or ECU is replaced, the code re-registering key must be registered to the unit.

To register a code re-registering key:

1. Turn the main switch to "ON" with the code re-registering key.

**NOTE:**

Check that the immobilizer system indicator light comes on for one second, then goes off. When the immobilizer system indicator light goes off, the code re-registering key has been registered.

2. Check that the engine can be started.
3. Register the standard key, following the instructions in the section below.

**Standby mode:**

To enable the immobilizer system, turn the ignition key to "OFF". 30 seconds later, the indicator light will start flashing continuously in the standby flashing mode pattern for up to 24 hours. After that time, the indicator light will stop flashing, but the immobilizer system is still enabled.

## IMMOBILIZER SYSTEM

### Standby mode

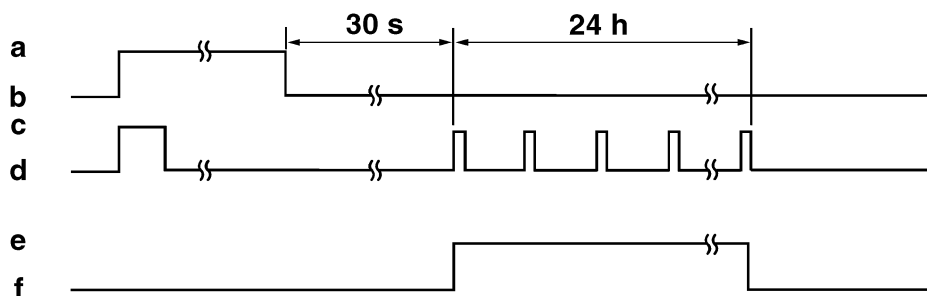

- a. Main switch "ON"
- b. Main switch "OFF"
- c. LED on

- d. LED off
- e. Standby mode on
- f. Standby mode off

### Standard key registration:

Standard key registration is required when a standard key is lost and needs to be replaced, or when the code re-registering key is re-registered after the immobilizer unit or ECU are replaced.

#### NOTE:

Do not start the engine with a standard key that has not been registered. If the main switch is turned "ON" with a standard key that has not been registered, the immobilizer system indicator light flashes to indicate fault code "52". (Refer to "SELF-DIAGNOSIS FAULT CODE INDICATION" on page 8-78).

1. Check that the immobilizer system indicator light signals the standby mode.
2. Using the code re-registering key, turn the main switch to "ON", then "OFF", and then remove the key within 5 seconds.
3. Insert the first standard key to be registered into the main switch, then turn the key to "ON" within 5 seconds to activate the key registration mode.

#### NOTE:

The existing standard key code is erased from the memory when the key registration mode is activated. When the key registration mode is activated, the immobilizer system indicator light flashes rapidly.

4. While the indicator light is flashing, turn the main switch to "OFF", remove the key, and within 5 seconds, insert the second standard key to be registered into the main switch.

#### NOTE:

If the immobilizer system indicator light stops flashing 5 seconds after the first standard key is registered, the registration mode is deactivated. If this occurs, the second standard key cannot be registered, and steps 2 to 4 need to be repeated to register both standard keys.

5. Turn the main switch to "ON".

#### NOTE:

When the indicator light goes off, the registration is complete.

6. Check that the engine can be started with the two registered standard keys.

## IMMOBILIZER SYSTEM

### Standard key registration

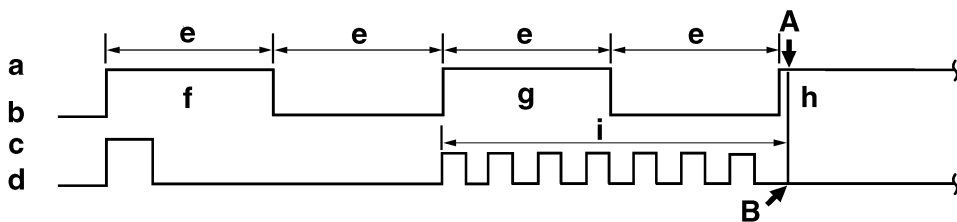

- a. Main switch "ON"
- b. Main switch "OFF"
- c. LED on
- d. LED off
- e. Less than 5.0 s
- f. Code re-registering key
- g. First standard key
- h. Second standard key
- i. Registration mode
- A. Registration of the second standard key is complete.
- B. Immobilizer system indicator light stops flashing when the registration of the second standard key is complete.

### Voiding the standard key code:

If a standard key has been lost, it is possible to disable its use by re-registering the remaining standard key. Standard key registration erases the stored standard key code from the memory, thus disabling the lost standard key. To re-register, refer to "Standard key registration".

### Standard key code voiding method

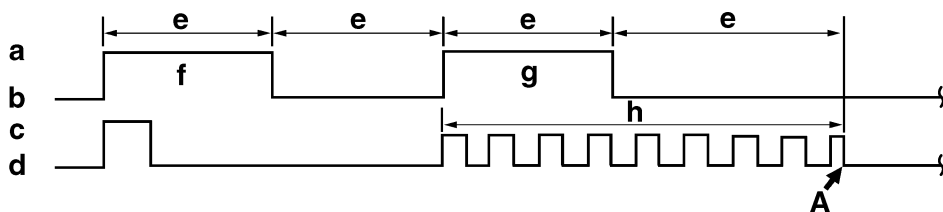

- a. Main switch "ON"
- b. Main switch "OFF"
- c. LED on
- d. LED off
- e. Less than 5.0 s
- f. Code re-registering key
- g. Remaining standard key
- h. Registration mode
- A. If the immobilizer system indicator light stops flashing 5 seconds after the first standard key is registered, the second standard key cannot be registered.

## IMMOBILIZER SYSTEM

EAS27701

### TROUBLESHOOTING

When the main switch is turned to "ON", the immobilizer system indicator light does not come on nor flashes.

1 Check the fuses. (Main, ignition and backup) Refer to "CHECKING THE FUSES" on page 8-89.	NG→	Replace the fuse(s).
OK↓		
2 Check the battery. Refer to "CHECKING AND CHARGING THE BATTERY" on page 8-89.	NG→	<ul style="list-style-type: none"><li>• Clean the battery terminals.</li><li>• Recharge or replace the battery.</li></ul>
OK↓		
3 Check the main switch. Refer to "CHECKING THE SWITCHES" on page 8-85.	NG→	Replace the main switch/immobilizer unit.
OK↓		
4 Check the entire immobilizer sys- tem wiring. Refer to "IMMOBILIZER SYSTEM" on page 8-71.	NG→	Properly connect or repair the immobi- lizer system wiring.
OK↓		
<ul style="list-style-type: none"><li>• Check the condition of the each immobilizer system circuits.</li><li>• Refer to "SELF-DIAGNOSIS FAULT CODE INDICATION" on page 8-78.</li></ul>		

**IMMOBILIZER SYSTEM**

EAS27721

**SELF-DIAGNOSIS FAULT CODE INDICATION**

When a system failure occurs, the error code number is indicated in the LCD display of meter and the immobilizer system indicator light blinks at the same time. The pattern of blinking also shows the error code.

<b>Fault code</b>	<b>Part</b>	<b>Symptom</b>	<b>Cause</b>	<b>Action</b>
51	IMMOBILIZER UNIT	Code cannot be transmitted between the key and immobilizer unit.	1 Radio wave interference caused by objects around the keys and antennas. 2 Immobilizer unit malfunction. 3 Key malfunction.	1 Keep magnets, metal objects, and other immobilizer system keys away from the keys and antennas. 2 Replace the main switch/immobilizer unit. 3 Replace the key.
52	IMMOBILIZER UNIT	Codes between the key and immobilizer unit do not match.	1 Signal received from other transponder (failed to recognize code after ten consecutive attempts). 2 Signal received from unregistered standard key.	1 Place the immobilizer unit at least 50 mm away from the transponder of other vehicles. 2 Register the standard key.
53	IMMOBILIZER UNIT	Codes cannot be transmitted between the ECU and the immobilizer unit.	Noise interference or disconnected lead/cable. 1 Interference due to radio wave noise. 2 Disconnected communication harness. 3 Immobilizer unit malfunction. 4 ECU malfunction.	1 Check the wire harness and connector. 2 Replace the main switch/immobilizer unit. 3 Replace the ECU.
54	IMMOBILIZER UNIT	Codes transmitted between the ECU and the immobilizer unit do not match.	Noise interference or disconnected lead/cable. 1 Interference due to radio wave noise. 2 Disconnected communication harness. 3 Immobilizer unit malfunction. 4 ECU failure. (The ECU or immobilizer unit was replaced with a used unit from another vehicle.)	1 Register the code re-registering key. 2 Check the wire harness and connector. 3 Replace the main switch/immobilizer unit. 4 Replace the ECU.
55	IMMOBILIZER UNIT	Key code registration malfunction.	Same standard key was attempted to be registered two consecutive times.	Register another standard key.

## IMMOBILIZER SYSTEM

Fault code	Part	Symptom	Cause	Action
56	ECU	Undefined code is received.	Noise interference or disconnected lead/cable.	1 Check the wire harness and connector. 2 Replace the main switch/immobilizer unit. 3 Replace the ECU.

### Immobilizer system indicator light fault code indication

Digit of 10 : Cycles of 1 sec. ON and 1.5 sec. OFF.

Digit of 1 : Cycles of 0.5 sec. ON and 0.5 sec. OFF.

Example: fault code 52

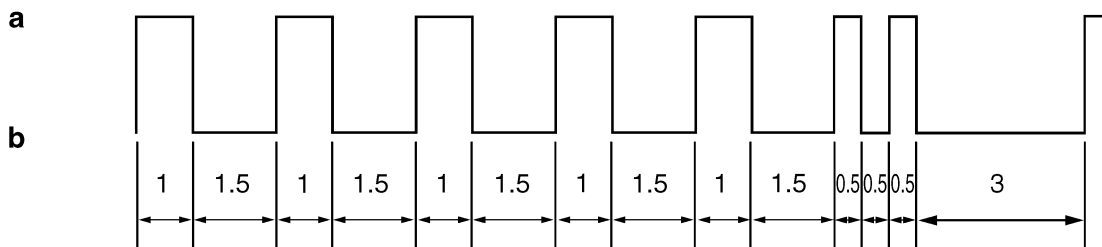

- a. Light on
- b. Light off

## **IMMOBILIZER SYSTEM**

---

# ELECTRICAL COMPONENTS

EAS27970

## ELECTRICAL COMPONENTS

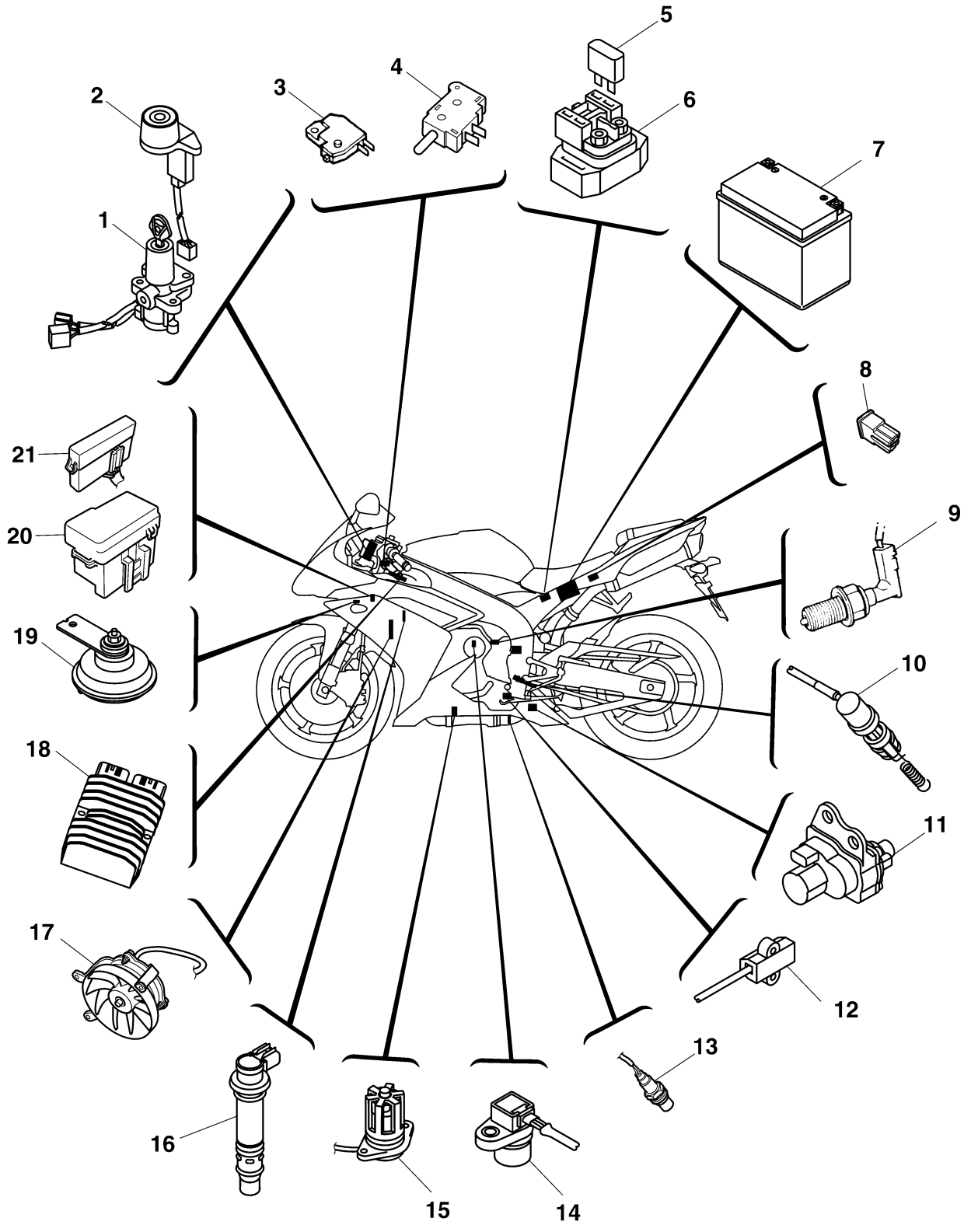

## ELECTRICAL COMPONENTS

---

1. Main switch
2. Immobilizer unit
3. Front brake light switch
4. Clutch switch
5. Fuel injection system fuse
6. Starter relay
7. Battery
8. Main fuse
9. Neutral switch
10. Rear brake light switch
11. EXUP servo motor
12. Sidestand switch
13. O<sub>2</sub> sensor
14. Speed sensor
15. Oil level switch
16. Ignition coil
17. Radiator fan motor
18. Rectifier/regulator
19. Horn
20. Fuse box (radiator fan motor, signaling system, ignition, ETV, backup)
21. Fuse box (headlight, turn)

# ELECTRICAL COMPONENTS

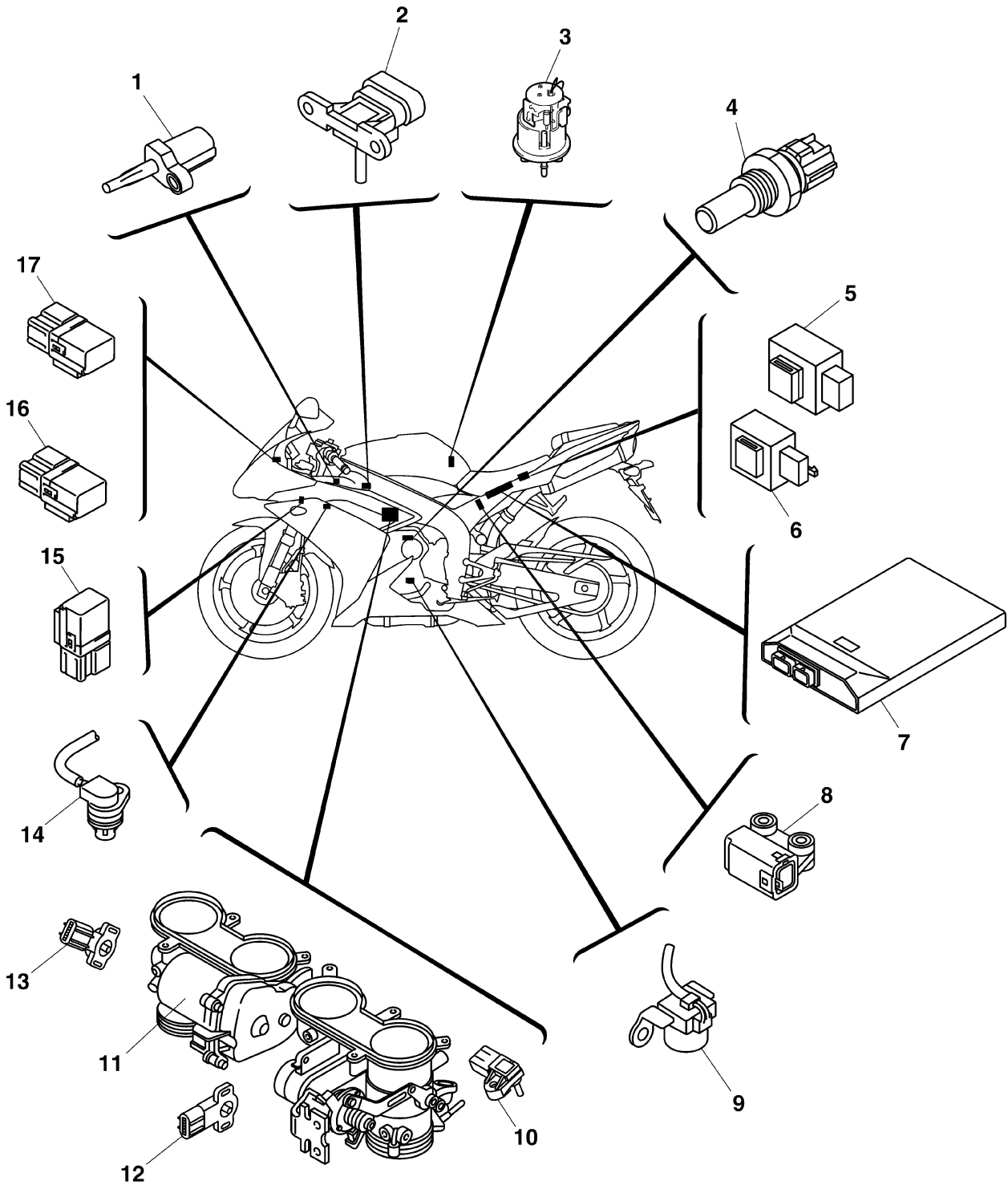

## ELECTRICAL COMPONENTS

---

1. Air temperature sensor
2. Atmospheric pressure sensor
3. Fuel pump
4. Coolant temperature sensor
5. Starting circuit cut-off relay
6. Turn signal/hazard relay
7. ECU (engine control unit)
8. Lean angle sensor
9. Crankshaft position sensor
10. Intake air pressure sensor
11. Throttle servo motor
12. Throttle position sensor (for throttle cable pulley)
13. Throttle position sensor (for throttle valves)
14. Cylinder identification sensor
15. Radiator fan motor relay
16. Headlight relay (dimmer)
17. Headlight relay (on/off)

# ELECTRICAL COMPONENTS

EAS27980

## CHECKING THE SWITCHES

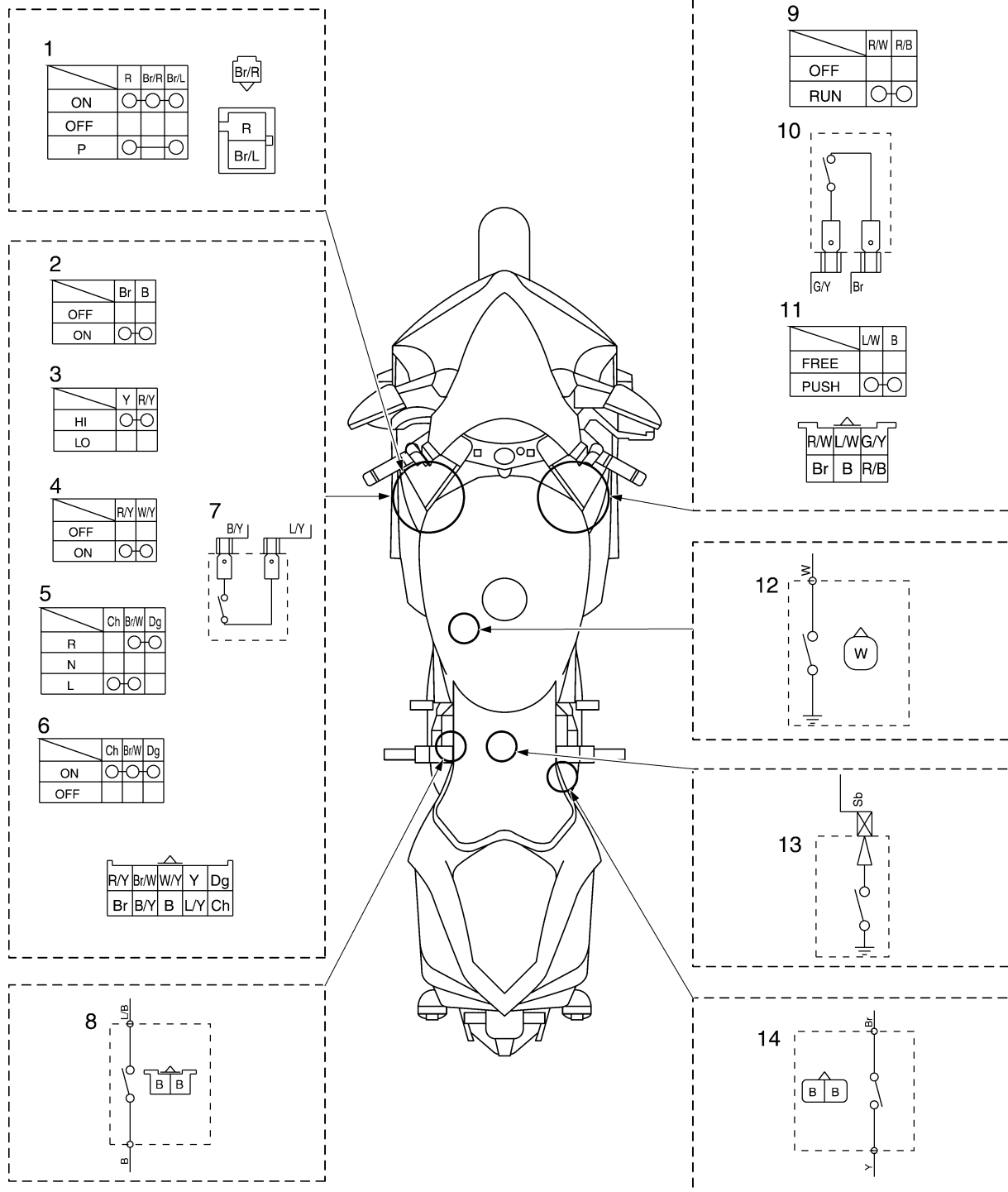

## **ELECTRICAL COMPONENTS**

---

1. Main switch
2. Horn switch
3. Dimmer switch
4. Pass switch
5. Turn signal switch
6. Hazard switch
7. Clutch switch
8. Sidestand switch
9. Engine stop switch
10. Front brake light switch
11. Start switch
12. Oil level switch
13. Neutral switch
14. Rear brake light switch

## ELECTRICAL COMPONENTS

Check each switch for continuity with the pocket tester. If the continuity reading is incorrect, check the wiring connections and if necessary, replace the switch.

ECA14370

**CAUTION:**

**Never insert the tester probes into the coupler terminal slots "a". Always insert the probes from the opposite end of the coupler, taking care not to loosen or damage the leads.**

	<p><b>Pocket tester</b>  <b>90890-03112</b>  <b>Analog pocket tester</b>  <b>YU-03112-C</b></p>
---	---

**NOTE:**

- Before checking for continuity, set the pocket tester to "0" and to the " $\Omega \times 1$ " range.
- When checking for continuity, switch back and forth between the switch positions a few times.

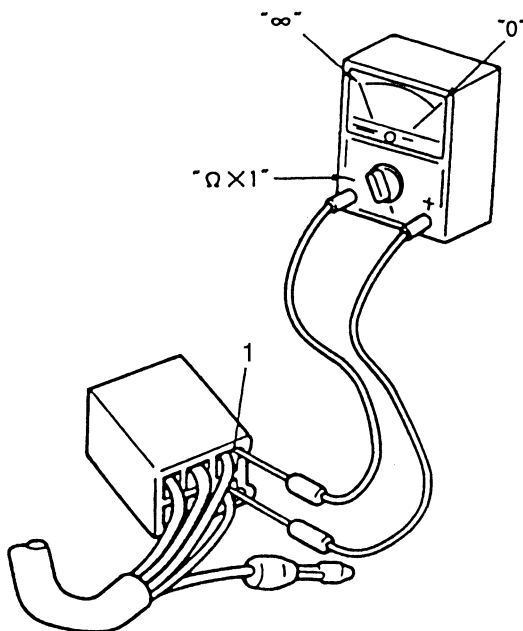

The switches and their terminal connections are illustrated as in the following example of the main switch.

The switch positions "a" are shown in the far left column and the switch lead colors "b" are shown in the top row.

The continuity (i. e., a closed circuit) between switch terminals at a given switch position is indication by "○—○" There is continuity between red, brown/blue, and brown/red when the switch is set to "ON" and between red and brown/red when the switch is set to "P".

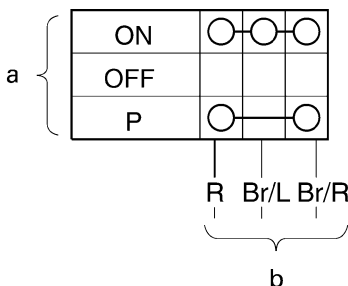

## ELECTRICAL COMPONENTS

EAS27990

### CHECKING THE BULBS AND BULB SOCKETS

Check each bulb and bulb socket for damage or wear, proper connections, and also for continuity between the terminals.

Damage/wear → Repair or replace the bulb, bulb socket or both.

Improperly connected → Properly connect.

No continuity → Repair or replace the bulb, bulb socket or both.

#### Types of bulbs

The bulbs used on this vehicle are shown in the illustration.

- Bulbs “a” are used for the headlights and usually use a bulb holder that must be detached before removing the bulb.
- Bulbs “b” is used for turn signal and can be removed from the socket by pushing and turning the bulb counterclockwise.
- Bulbs “c” are used for auxiliary lights and can be removed from their respective socket by carefully pulling them out.

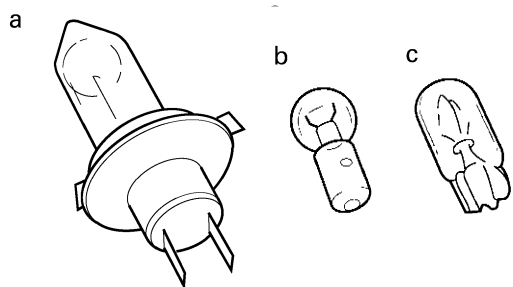

#### Checking the condition of the bulbs

The following procedure applies to all of the bulbs.

1. Remove:
  - Bulb

EWA13320



**Since the headlight bulb gets extremely hot, keep flammable products and your hands away from the bulb until it has cooled down.**

ECA14380

#### CAUTION:

- Be sure to hold the socket firmly when removing the bulb. Never pull the lead, otherwise it may be pulled out of the terminal in the coupler.
- Avoid touching the glass part of the headlight bulb to keep it free from oil, other-

wise the transparency of the glass, the life of the bulb, and the luminous flux will be adversely affected. If the headlight bulb gets soiled, thoroughly it with a cloth moistened with alcohol or lacquer thinner.

2. Check:

- Bulb (for continuity) (with the pocket tester)  
No continuity → Replace.



**Pocket tester**  
**90890-03112**  
**Analog pocket tester**  
**YU-03112-C**

#### NOTE:

Before checking for continuity, set the pocket tester to “0” and to the “Ω × 1” range.

- a. Connect the positive tester probe to terminal “1” and the negative tester probe to terminal “2”, and check the continuity.
- b. If reading indicate no continuity, replace the bulb.

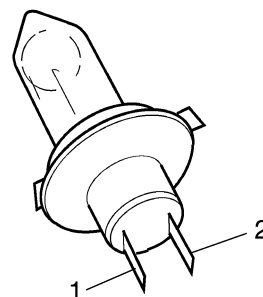

#### Checking the condition of the bulb sockets

The following procedure applies to all of the bulb sockets.

1. Check:

- Bulb socket (for continuity) (with the pocket tester)  
No continuity → Replace.



**Pocket tester**  
**90890-03112**  
**Analog pocket tester**  
**YU-03112-C**

## ELECTRICAL COMPONENTS

**NOTE:** \_\_\_\_\_

Check each bulb socket for continuity in the same manner as described in the bulb section; however, note the following.



- a. Install a good bulb into the bulb socket.
- b. Connect the pocket tester probes to the respective leads of the bulb socket.
- c. Check the bulb socket for continuity. If any of the readings indicate no continuity, replace the bulb socket.



EAS28000

**CHECKING THE FUSES**

The following procedure applies to all of the fuses.

ECA13680

**CAUTION:** \_\_\_\_\_

**To avoid a short circuit, always set the main switch to “OFF” when checking or replacing a fuse.**

1. Remove:
  - Rider seat
  - Passenger seat
  - Side cowlings
2. Check:
  - Fuse



- a. Connect the pocket tester to the fuse and check the continuity.

**NOTE:** \_\_\_\_\_

Set the pocket tester selector to “Ω × 1”.

	<p><b>Pocket tester</b> 90890-03112</p> <p><b>Analog pocket tester</b> YU-03112-C</p>
---	---

- b. If the pocket tester indicates “∞”, replace the fuse.



3. Replace:
  - Blown fuse



- a. Set the main switch to “OFF”.
- b. Install a new fuse of the correct amperage rating.
- c. Set on the switches to verify if the electrical circuit is operational.

- d. If the fuse immediately blows again, check the electrical circuit.

Fuses	Amperage rating	Q'ty
Main	50 A	1
Headlight	25 A	1
Signaling system	7.5 A	1
Backup	7.5 A	1
ETV	7.5 A	1
Turn	7.5 A	1
Ignition	15 A	1
Radiator fan motor	15 A	2
Reserve	7.5 A	1
Reserve	1.5 A	1
Reserve	25 A	1

EWA13310

**WARNING** \_\_\_\_\_

**Never use a fuse with an amperage rating other than that specified. Improvising or using a fuse with the wrong amperage rating may cause extensive damage to the electrical system, cause the lighting and ignition systems to malfunction and could possibly cause a fire.**



4. Install:
  - Side cowlings
  - Passenger seat
  - Rider seat

EAS28030

**CHECKING AND CHARGING THE BATTERY**

EWA13290

**WARNING** \_\_\_\_\_

**Batteries generate explosive hydrogen gas and contain electrolyte which is made of poisonous and highly caustic sulfuric acid. Therefore, always follow these preventive measures:**

- **Wear protective eye gear when handling or working near batteries.**
- **Charge batteries in a well-ventilated area.**
- **Keep batteries away from fire, sparks or open flames (e.g., welding equipment, lighted cigarettes).**
- **DO NOT SMOKE when charging or handling batteries.**
- **KEEP BATTERIES AND ELECTROLYTE OUT OF REACH OF CHILDREN.**

## ELECTRICAL COMPONENTS

- Avoid bodily contact with electrolyte as it can cause severe burns or permanent eye injury.

### FIRST AID IN CASE OF BODILY CONTACT: EXTERNAL

- Skin — Wash with water.
- Eyes — Flush with water for 15 minutes and get immediate medical attention.

### INTERNAL

- Drink large quantities of water or milk followed with milk of magnesia, beaten egg or vegetable oil. Get immediate medical attention.

ECA13660

#### CAUTION:

- This is a sealed battery. Never remove the sealing caps because the balance between cells will not be maintained and battery performance will deteriorate.
- Charging time, charging amperage and charging voltage for an MF battery are different from those of conventional batteries. The MF battery should be charged as explained in the charging method illustrations. If the battery is overcharged, the electrolyte level will drop considerably. Therefore, take special care when charging the battery.

#### NOTE:

Since MF batteries are sealed, it is not possible to check the charge state of the battery by measuring the specific gravity of the electrolyte. Therefore, the charge of the battery has to be checked by measuring the voltage at the battery terminals.

1. Remove:
  - Rider seat  
Refer to "GENERAL CHASSIS" on page 4-1.
2. Disconnect:
  - Battery leads  
(from the battery terminals)

ECA13640

#### CAUTION:

First, disconnect the negative battery lead "1", and then positive battery lead "2".

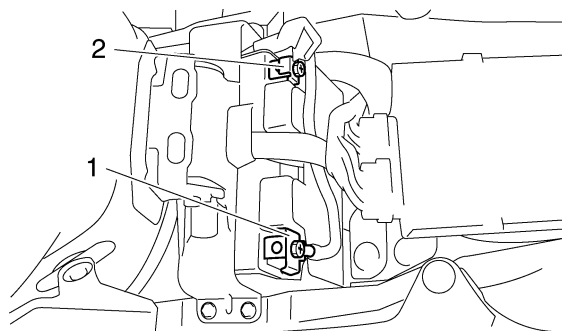

3. Remove:
  - Battery
4. Check:
  - Battery charge



- a. Connect a pocket tester to the battery terminals.

- Positive tester probe → positive battery terminal
- Negative tester probe → negative battery terminal

#### NOTE:

- The charge state of an MF battery can be checked by measuring its open-circuit voltage (i.e., the voltage when the positive battery terminal is disconnected).
- No charging is necessary when the open-circuit voltage equals or exceeds 12.8 V.

- b. Check the charge of the battery, as shown in the charts and the following example.

- Example  
 Open-circuit voltage = 12.0 V  
 Charging time = 6.5 hours  
 Charge of the battery = 20–30%



5. Charge:
  - Battery  
(refer to the appropriate charging method illustration)

EWA13300

#### WARNING

Do not quick charge a battery.

ECA13670

#### CAUTION:

- Never remove the MF battery sealing caps.
- Do not use a high-rate battery charger since it forces a high-amperage current

## ELECTRICAL COMPONENTS

into the battery quickly and can cause battery overheating and battery plate damage.

- If it is impossible to regulate the charging current on the battery charger, be careful not to overcharge the battery.
- When charging a battery, be sure to remove it from the vehicle. (If charging has to be done with the battery mounted on the vehicle, disconnect the negative battery lead from the battery terminal.)
- To reduce the chance of sparks, do not plug in the battery charger until the battery charger leads are connected to the battery.
- Before removing the battery charger lead clips from the battery terminals, be sure to turn off the battery charger.
- Make sure the battery charger lead clips are in full contact with the battery terminal and that they are not shorted. A corroded battery charger lead clip may generate heat in the contact area and a weak clip spring may cause sparks.
- If the battery becomes hot to the touch at any time during the charging process, disconnect the battery charger and let the battery cool before reconnecting it. Hot batteries can explode!
- As shown in the following illustration, the open-circuit voltage of an MF battery stabilizes about 30 minutes after charging has been completed. Therefore, wait 30 minutes after charging is completed before measuring the open-circuit voltage.



### Charging method using a variable-current (voltage) charger

- a. Measure the open-circuit voltage prior to charging.

**NOTE:** \_\_\_\_\_  
Voltage should be measured 30 minutes after the machine is stopped.

- b. Connect a charged and AMP meter to the battery and start charging.

**NOTE:** \_\_\_\_\_  
Set the charging voltage at 16–17 V. If the setting is lower, charging will be insufficient. If too high, the battery will be over-charged.

- c. Make sure that the current is higher than the standard charging current written on the battery.

**NOTE:** \_\_\_\_\_  
If the current is lower than the standard charging current written on the battery, set the charging voltage adjust dial at 20–24 V and monitor the amperage for 3–5 minutes to check the battery.

- Reach the standard charging current  
Battery is good.
- Does not reach the standard charging current  
Replace the battery.

- d. Adjust the voltage so that the current is at the standard charging level.
- e. Set the time according to the charging time suitable for the open-circuit voltage. Refer to “Battery condition checking steps”.
- f. If charging requires more than 5 hours, it is advisable to check the charging current after a lapse of 5 hours. If there is any change in the amperage, readjust the voltage to obtain the standard charging current.
- g. Measure the battery open-circuit voltage after leaving the battery unused for more than 30 minutes.

- 12.8 V or more --- Charging is complete.
- 12.7 V or less --- Recharging is required.
- Under 12.0 V --- Replace the battery.



### Charging method using a constant voltage charger

- a. Measure the open-circuit voltage prior to charging.

**NOTE:** \_\_\_\_\_  
Voltage should be measured 30 minutes after the machine is stopped.

- b. Connect a charger and AMP meter to the battery and start charging.
- c. Make sure that the current is higher than the standard charging current written on the battery.

**NOTE:** \_\_\_\_\_  
If the current is lower than the standard charging current written on the battery, This type of







## ELECTRICAL COMPONENTS

- a. Disconnect the relay unit coupler from the wire harness.
- b. Connect the pocket tester ( $\Omega \times 1$ ) to the relay unit terminal as shown.
- c. Check the relay unit (diode) for continuity.
- d. Check the relay unit (diode) for no continuity.

EAS28100

### CHECKING THE IGNITION COILS

The following procedure applies to all of the ignition coils.

1. Check:
  - Primary coil resistance  
Out of specification → Replace.



**Primary coil resistance**  
0.85–1.15  $\Omega$  at 20 °C (68°F)

- a. Disconnect the ignition coil connectors from the ignition coil terminals.
- b. Connect the pocket tester ( $\Omega \times 1$ ) to the ignition coil as shown.



**Pocket tester**  
90890-03112  
**Analog pocket tester**  
YU-03112-C

- Positive tester probe  
Ignition coil terminal
- Negative tester probe  
Ignition coil terminal

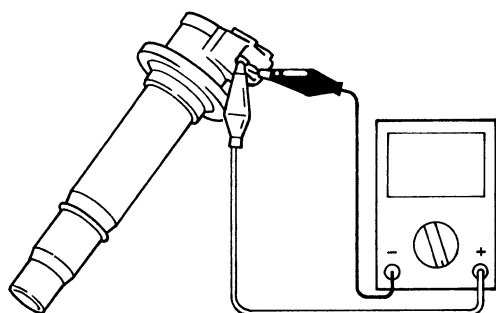

- c. Measure the primary coil resistance.

2. Check:
  - Secondary coil resistance  
Out of specification → Replace.



**Secondary coil resistance**  
5.02–6.79 k $\Omega$  at 20 °C (68 °F)

- a. Disconnect the ignition coil leads from the ignition coil.
- b. Connect the pocket tester ( $\Omega \times 1k$ ) to the ignition coil as shown.



**Pocket tester**  
90890-03112  
**Analog pocket tester**  
YU-03112-C

- Negative tester probe  
Ignition coil terminal “1”
- Positive tester probe  
Spark plug terminal “2”

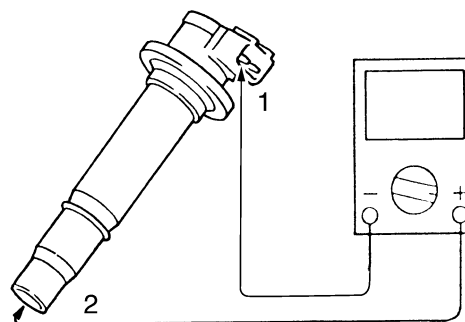

- c. Measure the secondary coil resistance.

3. Check:
  - Ignition spark gap  
Out of specification → Replace.



**Minimum ignition spark gap**  
6.0 mm (0.24 in)

- a. Disconnect the ignition coil from the spark plug.
- b. Connect the ignition checker/dynamic spark tester “2” as shown.



**Ignition checker**  
90890-06754  
**Opama pet-4000 spark checker**  
YM-34487

# ELECTRICAL COMPONENTS

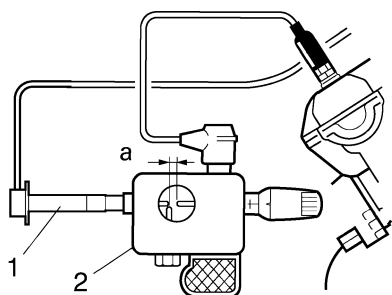

18110202

1. Ignition coil
- c. Set the main switch to "ON".
- d. Measure the ignition spark gap "a".
- e. Crank the engine by pushing the starter switch and gradually increase the spark gap until a misfire occurs.



EAS28120

## CHECKING THE CRANKSHAFT POSITION SENSOR

1. Disconnect:
  - Crankshaft position sensor coupler (from the wire harness)
2. Check:
  - Crankshaft position sensor resistance  
Out of specification → Replace the crankshaft position sensor.

	<b>Crankshaft position sensor resistance</b> 336–504 Ω at 20°C (68°F)
---	--



- a. Connect the pocket tester ( $\Omega \times 100$ ) to the crankshaft position sensor coupler as shown.

	<b>Pocket tester</b> 90890-03112 <b>Analog pocket tester</b> YU-03112-C
---	--

- Positive tester probe  
Gray "1"
- Negative tester probe  
Black "2"

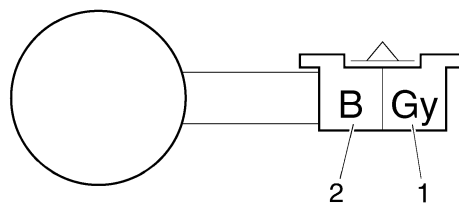

- b. Measure the crankshaft position sensor resistance.



EAS28130

## CHECKING THE LEAN ANGLE SENSOR

1. Remove:
  - Lean angle sensor (from the bracket.)
2. Check:
  - Lean angle sensor out put voltage  
Out of specification → Replace.

	<b>Lean angle sensor out put voltage</b> Less than 65°: 0.4–1.4 V More than 65°: 3.7–4.4 V
---	--



- a. Connect the lean angle sensor coupler to the wire harness.
- b. Connect the pocket tester (DC 20 V) to the lean angle sensor coupler as shown.

	<b>Pocket tester</b> 90890-03112 <b>Analog pocket tester</b> YU-03112-C
---	--

- Positive tester probe  
Yellow/Green "1"
- Negative tester probe  
Black/Blue "2"

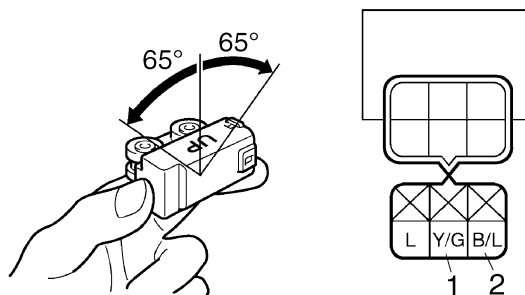

- c. When turn the lean angle sensor to 65°.

## ELECTRICAL COMPONENTS

d. Measure the lean angle sensor out put voltage.



EAS4C81020

### CHECKING THE STARTER MOTOR OPERATION

1. Check:

- Starter motor operation  
Does not operate → Perform the electric starting system troubleshooting, starting with step 4.  
Refer to "TROUBLESHOOTING" on page 8-9.



a. Connect the positive battery terminal "1" and starter motor lead "2" with a jumper lead "3".

EWA13810

#### WARNING

- A wire that is used as a jumper lead must have at least the same capacity of the battery lead, otherwise the jumper lead may burn.
- This check is likely to produce sparks, therefore, make sure no flammable gas or fluid is in the vicinity.

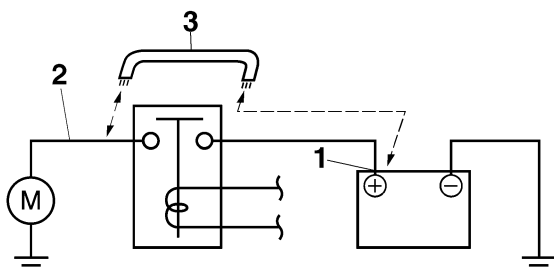

b. Check the starter motor operation.



EAS28150

### CHECKING THE STATOR COIL

1. Disconnect:

- Stator coil coupler  
(from the rectifier/regulator)

2. Check:

- Stator coil resistance  
Out of specification → Replace the stator coil.

**Stator coil resistance**  
0.14–0.18 Ω at 20°C (68°F)



a. Connect the pocket tester ( $\Omega \times 1$ ) to the stator coil coupler as shown.

**Pocket tester**  
90890-03112  
**Analog pocket tester**  
YU-03112-C

- Positive tester probe  
White "1"
- Negative tester probe  
White "2"

- Positive tester probe  
White "1"
- Negative tester probe  
White "3"

- Positive tester probe  
White "2"
- Negative tester probe  
White "3"

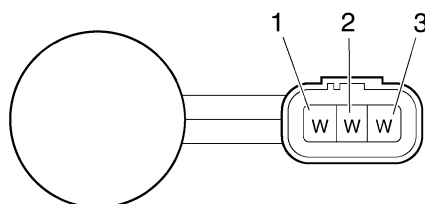

b. Measure the stator coil resistance.



EAS28170

### CHECKING THE RECTIFIER/REGULATOR

1. Check:

- Charging voltage  
Out of specification → Replace the rectifier/regulator.

**Charging voltage**  
14 V at 5000 r/min



- a. Set the engine tachometer to the ignition coil of cylinder #1.
- b. Connect the pocket tester (AC 20 V) to the rectifier/regulator coupler as shown.

## ELECTRICAL COMPONENTS



**Pocket tester**  
**90890-03112**  
**Analog pocket tester**  
**YU-03112-C**

- Positive tester probe  
Red "1"
- Negative tester probe  
Black "2"

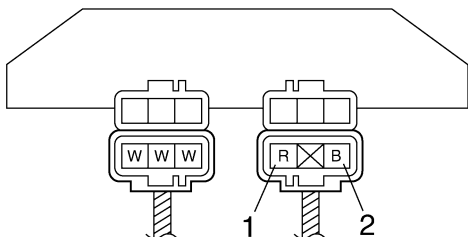

- Start the engine and let it run at approximately 5000 r/min.
- Measure the charging voltage.

EAS28180

### CHECKING THE HORN

- Check:
  - Horn resistance  
Out of specification → Replace.



**Horn resistance**  
**1.15–1.25 Ω at 20°C (68°F)**

- Disconnect the horn leads from the horn terminals.
- Connect the pocket tester ( $\Omega \times 1$ ) to the horn terminals.



**Pocket tester**  
**90890-03112**  
**Analog pocket tester**  
**YU-03112-C**

- Positive tester probe  
Horn terminal "1"
- Negative tester probe  
Horn terminal "2"

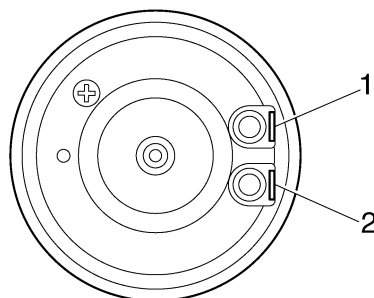

- Measure the horn resistance.

- Check:
  - Horn sound  
Faulty sound → Adjust or replace.

- Connect a battery (12 V) to the horn.
- Turn the adjusting screw in direction "a" or "b" until the specified horn sound is obtained.

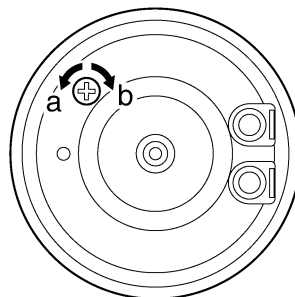

EAS28190

### CHECKING THE OIL LEVEL SWITCH

- Drain:
  - Engine oil
- Remove:
  - Oil level switch  
(from the oil pan)
- Check:
  - Oil level switch resistance

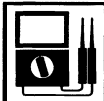

**Oil level switch**  
**Maximum level position resistance**  
**484–536 Ω at 20°C (68°F)**  
**Minimum level position resistance**  
**114–126 Ω at 20°C (68°F)**

- Connect the pocket tester ( $\Omega \times 100$ ) to the oil level switch terminal as shown.

## ELECTRICAL COMPONENTS

**Pocket tester**  
90890-03112  
**Analog pocket tester**  
YU-03112-C

Maximum level position "A"

- Positive tester probe  
Connector (white) "1"
- Negative tester probe  
Body earth "2"

Minimum level position "B"

- Positive tester probe  
Connector (white) "1"
- Negative tester probe  
Body earth "2"

**Pocket tester**  
90890-03112  
**Analog pocket tester**  
YU-03112-C

- Positive tester probe  
Green/white "1"
- Negative tester probe  
Black "2"

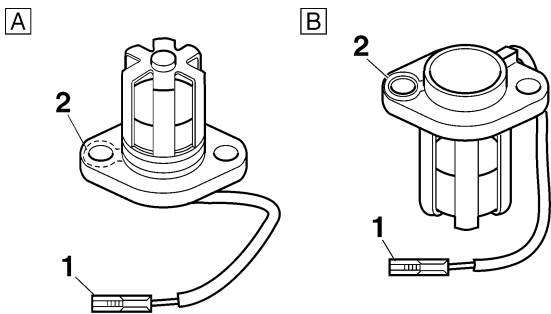
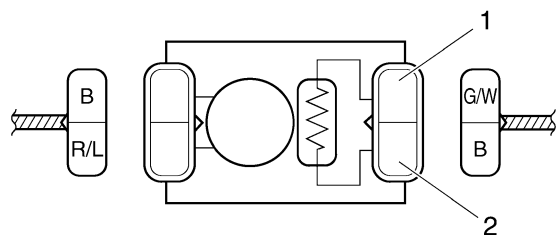

b. Measure the pickup coil resistance.



EAS28230

### CHECKING THE FUEL SENDER

1. Disconnect:
  - Fuel pump coupler
  - Fuel sender coupler (from the wire harness)
2. Remove:
3. Remove:
4. Check:

**Fuel sender resistance**  
19–141Ω at 20°C (68°F)

a. Connect the pocket tester ( $\Omega \times 1$ ) to the fuel sender terminal as shown.



b. Measure the fuel sender resistance.



EAS28240

### CHECKING THE SPEED SENSOR

1. Check:
  - Speed sensor output voltage  
Out of specification → Replace.

**Output voltage reading cycle**  
0.6 V to 4.8 V to 0.6 V to 4.8 V

a. Connect the pocket tester (DC 20 V) to the speed sensor coupler (wire harness side) as shown.

**Pocket tester**  
90890-03112  
**Analog pocket tester**  
YU-03112-C

- Positive tester probe  
White/Yellow "1"
- Negative tester probe  
Black/Blue "2"

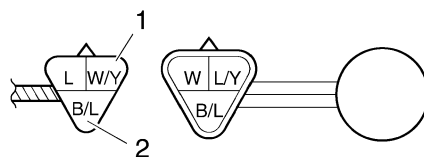

- b. Set the main switch to "ON".
- c. Elevate the rear wheel and slowly rotate it.

## ELECTRICAL COMPONENTS

- d. Measure the voltage (DC 5 V) of White/Yellow and Black/Blue. With each full rotation of the rear wheel, the voltage reading should cycle from 0.6 V 4.8V to 0.6 V to 4.8 V.



EAS4C81021

### CHECKING THE RADIATOR FAN MOTORS

1. Check:
- Radiator fan motor
  - Faulty/rough movement → Replace.



- a. Disconnect the radiator fan motor coupler from the wire harness.  
 b. Connect the battery (DC 12 V) as shown.

- Positive tester probe  
Blue "1"
- Negative tester probe  
Black "2"

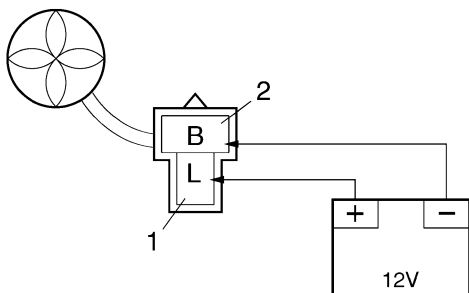

- c. Measure the radiator fan motor movement.



EAS28260

### CHECKING THE COOLANT TEMPERATURE SENSOR

1. Remove:
- Coolant temperature sensor

EWA14130



- Handle the coolant temperature sensor with special care.
- Never subject the coolant temperature sensor to strong shocks. If the coolant temperature sensor is dropped, replace it.

2. Check:
- Coolant temperature sensor resistance
  - Out of specification → Replace.

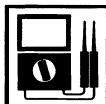

### Coolant temperature sensor resistance

0°C (32°F): 5.21–6.37 kΩ  
 80°C (176°F): 0.29–0.35 kΩ



- a. Connect the pocket tester ( $\Omega \times 100$ ) to the coolant temperature sensor "1" as shown.



Pocket tester  
 90890-03112  
 Analog pocket tester  
 YU-03112-C

- Positive tester probe  
Coolant temperature sensor terminal
- Negative tester probe  
Coolant temperature sensor terminal

- b. Immerse the coolant temperature sensor in a container filled with coolant "2".

**NOTE:**  
 Make sure the coolant temperature sensor terminals do not get wet.

- c. Place a thermometer "3" in the coolant.

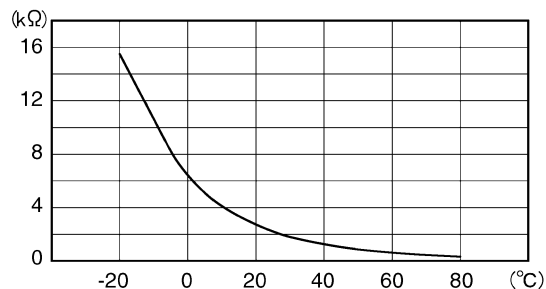
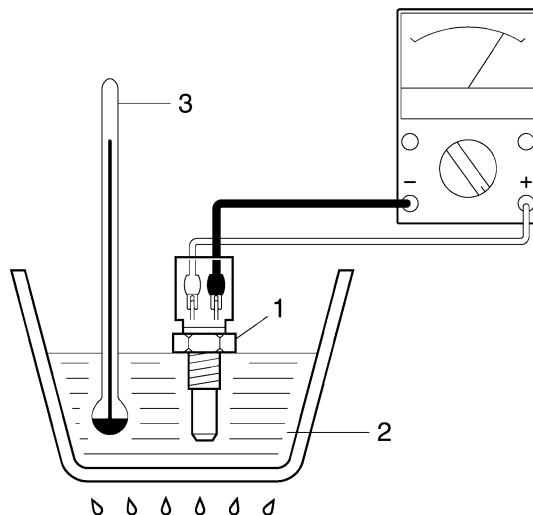

## ELECTRICAL COMPONENTS

- d. Slowly heat the coolant, and then let it cool to the specified temperature indicated in the table.
- e. Check the coolant temperature sensor for continuity at the temperatures indicated in the table.



EAS4C81022

### CHECKING THE THROTTLE POSITION SENSOR (FOR THROTTLE CABLE PULLEY)

1. Remove:
  - Throttle position sensor (for throttle cable pulley) (from the throttle body)
2. Check:
  - Throttle position sensor (for throttle cable pulley) maximum resistance  
Out of specification → Replace the throttle position sensor (for throttle cable pulley)

	<b>Resistance</b> 2.0–3.0 kΩ
--	---------------------------------



- a. Connect the pocket tester ( $\Omega \times 1k$ ) to the throttle position sensor terminal as shown.

	<b>Pocket tester</b> 90890-03112 <b>Analog pocket tester</b> YU-03112-C
---	--

- |  |
|--|
| <ul style="list-style-type: none"> <li>• Positive tester prove → White “1”</li> <li>• Negative tester prove → Black “2”</li> </ul> |
|--|

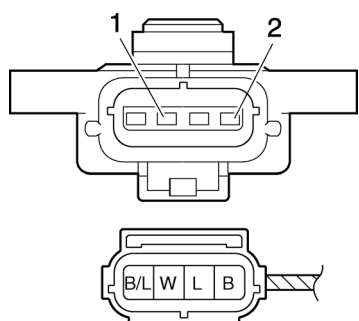

- b. Measure the throttle position sensor (for throttle cable pulley) maximum resistance.



3. Install:

- Throttle position sensor (for throttle cable pulley)

**NOTE:** \_\_\_\_\_

When installing the throttle position sensor (for throttle cable pulley), adjust its angle properly. Refer to "ADJUSTING THE THROTTLE POSITION SENSOR (FOR THROTTLE CABLE PULLEY)" on page 7-7.

EAS28300

### CHECKING THE THROTTLE POSITION SENSOR (FOR THROTTLE VALVES)

1. Remove:
  - Throttle position sensor (for throttle valves) (from the throttle body)
2. Check:
  - Throttle position sensor (for throttle valves) maximum resistance  
Out of specification → Replace the throttle position sensor (for throttle valves)

	<b>Resistance</b> 2.0–3.0 kΩ
--	---------------------------------



- a. Connect the pocket tester ( $\Omega \times 1k$ ) to the throttle position sensor as shown.

	<b>Pocket tester</b> 90890-03112 <b>Analog pocket tester</b> YU-03112-C
---	--

- |  |
|--|
| <ul style="list-style-type: none"> <li>• Positive tester prove → White “1”</li> <li>• Negative tester prove → Black “2”</li> </ul> |
|--|

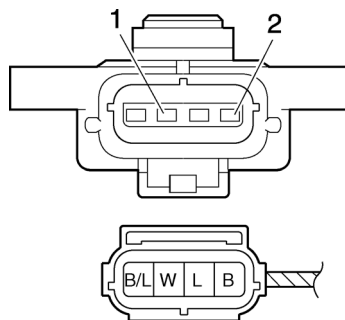

- b. Measure the throttle position sensor (for throttle valves) maximum resistance.



3. Install:

- Throttle position sensor (for throttle valves)

## ELECTRICAL COMPONENTS

**NOTE:**

When installing the throttle position sensor (for throttle valves), adjust its angle properly. Refer to "ADJUSTING THE THROTTLE POSITION SENSOR (FOR THROTTLE VALVES)" on page 7-6.

EAS28370

### CHECKING THE AIR INDUCTION SYSTEM SOLENOID

1. Check:
  - Air induction system solenoid resistance  
Out of specification → Replace.

	<b>Solenoid resistance</b> <b>18–22 Ω at 20°C (68°F)</b>
---	---

- a. Disconnect the air induction system solenoid coupler from the air induction system solenoid.
- b. Connect the pocket tester ( $\Omega \times 1$ ) to the air induction system solenoid terminal as shown.

	<b>Pocket tester</b> <b>90890-03112</b> <b>Analog pocket tester</b> <b>YU-03112-C</b>
---	--

- Positive tester probe  
Brown/Red "1"
- Negative tester probe  
Red/White "2"

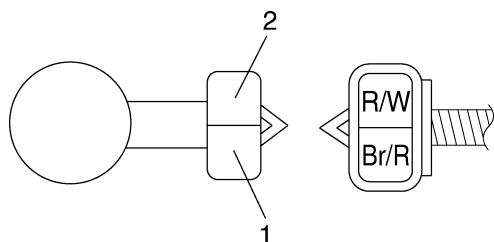

- c. Measure the air induction system solenoid resistance.

EAS28380

### CHECKING THE ATMOSPHERIC PRESSURE SENSOR

1. Check:
  - Atmospheric pressure sensor output voltage  
Out of specification → Replace.

	<b>Atmospheric pressure sensor resistance</b> <b>3.75–4.25 V</b>
---	---

- a. Connect the pocket tester (DC 20 V) to the atmospheric pressure sensor coupler (wire harness side) as shown.

	<b>Pocket tester</b> <b>90890-03112</b> <b>Analog pocket tester</b> <b>YU-03112-C</b>
---	--

- Positive tester probe  
Pink "1"
- Negative tester probe  
Black/Blue "2"

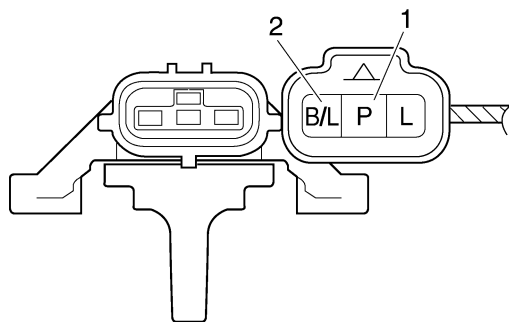

- b. Set the main switch to "ON".
- c. Measure the atmospheric pressure sensor output voltage.

EAS28390

### CHECKING THE CYLINDER IDENTIFICATION SENSOR

1. Check:
  - Cylinder identification sensor output voltage  
Out of specification → Replace.

	<b>Cylinder identification sensor output voltage</b> <b>When sensor is on</b> <b>4.8 V or more</b> <b>When sensor is off</b> <b>4.8 V or less</b>
---	---

- a. Connect the pocket tester (DC 20 V) to the cylinder identification sensor coupler (wire harness side) as shown.

## ELECTRICAL COMPONENTS



**Pocket tester  
90890-03112  
Analog pocket tester  
YU-03112-C**

- Positive tester probe  
White/Black "1"
- Negative tester probe  
Black/Blue "2"

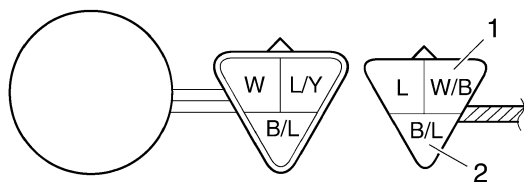

- b. Set the main switch to "ON".
- c. Rotate the crankshaft.
- d. Measure the voltage (DC 20 V) of White/Black and Black/Blue. With each full rotation of the crankshaft, the voltage reading should cycle from 0.8 V to 4.8 V to 0.8 V to 4.8 V.

EAS28410

### CHECKING THE INTAKE AIR PRESSURE SENSOR

1. Check:
  - Intake air pressure sensor output voltage  
Out of specification → Replace.

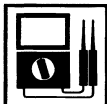

**Intake air pressure sensor output voltage  
3.15–4.15 V**

- a. Connect the pocket tester (DC 20 V) to the intake air pressure sensor coupler (wire harness side) as shown.



**Pocket tester  
90890-03112  
Analog pocket tester  
YU-03112-C**

- Positive tester probe  
Pink/White "1"
- Negative tester probe  
Black/Blue "2"

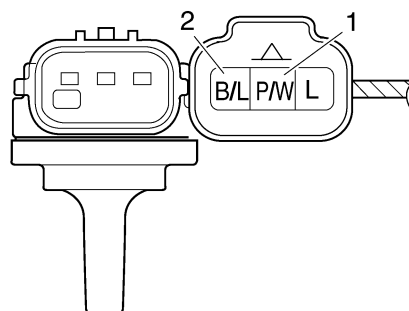

- b. Set the main switch to "ON".
- c. Measure the intake air pressure sensor output voltage.

EAS28420

### CHECKING THE INTAKE AIR TEMPERATURE SENSOR

1. Remove:
  - Intake air temperature sensor  
(from the air filter case.)

EWA14110

#### ⚠ WARNING

- Handle the intake air temperature sensor with special care.
- Never subject the intake air temperature sensor to strong shocks. If the intake air temperature sensor is dropped, replace it.

2. Check:
  - Intake air temperature sensor resistance  
Out of specification → Replace.

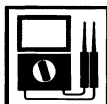

**Intake air pressure sensor resistance  
2.21–2.69 kΩ at 20°C (68°F)**

- a. Connect the pocket tester ( $\Omega \times 100$ ) to the intake air temperature sensor terminal as shown.



**Pocket tester  
90890-03112  
Analog pocket tester  
YU-03112-C**

- Positive tester probe  
Brown/White "1"
- Negative tester probe  
Black/Blue "2"

## ELECTRICAL COMPONENTS

---

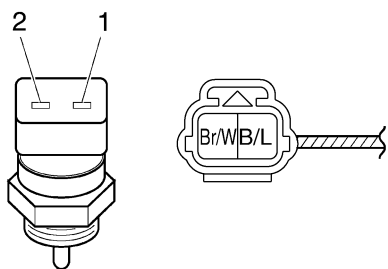

b. Measure the intake air temperature sensor resistance.



3. Install:

- Intake air temperature sensor

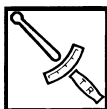

**Intake air temperature sensor  
bolt**  
**1.2 Nm (0.12 m·kg, 0.87 ft·lb)**

## **ELECTRICAL COMPONENTS**

---

---

## TROUBLESHOOTING

<b>TROUBLESHOOTING</b> .....	9-1
GENERAL INFORMATION .....	9-1
STARTING FAILURES .....	9-1
INCORRECT ENGINE IDLING SPEED .....	9-1
POOR MEDIUM-AND-HIGH-SPEED PERFORMANCE .....	9-2
FAULTY GEAR SHIFTING .....	9-2
SHIFT PEDAL DOES NOT MOVE .....	9-2
JUMPS OUT OF GEAR .....	9-2
FAULTY CLUTCH .....	9-2
OVERHEATING .....	9-2
OVER COOLING .....	9-3
POOR BRAKING PERFORMANCE .....	9-3
FAULTY FRONT FORK LEGS .....	9-3
UNSTABLE HANDLING .....	9-3
FAULTY LIGHTING OR SIGNALING SYSTEM .....	9-4

## TROUBLESHOOTING

EAS28450

### TROUBLESHOOTING

EAS28460

#### GENERAL INFORMATION

##### NOTE:

The following guide for troubleshooting does not cover all the possible causes of trouble. It should be helpful, however, as a guide to basic troubleshooting. Refer to the relative procedure in this manual for checks, adjustments, and replacement of parts.

EAS28470

#### STARTING FAILURES

##### Engine

1. Cylinder(s) and cylinder head(s)
  - Loose spark plug
  - Loose cylinder head
  - Damaged cylinder head gasket
  - Damaged cylinder gasket
  - Worn or damaged cylinder
  - Incorrect valve clearance
  - Improperly sealed valve
  - Incorrect valve-to-valve-seat contact
  - Incorrect valve timing
  - Faulty valve spring
  - Seized or damaged valve
2. Piston(s) and piston ring(s)
  - Improperly installed piston ring
  - Damaged, worn or fatigued piston ring
  - Seized piston ring
  - Seized or damaged piston
3. Air filter
  - Improperly installed air filter
  - Clogged air filter element
4. Crankcase and crankshaft
  - Improperly assembled crankcase
  - Seized or damaged crankshaft

##### Fuel system

1. Fuel tank
  - Empty fuel tank
  - Clogged fuel filter
  - Clogged fuel strainer
  - Clogged fuel tank drain hose
  - Deteriorated or contaminated fuel
2. Fuel pump
  - Faulty fuel pump
  - Faulty fuel pump relay
3. Throttle body (-ies)
  - Deteriorated or contaminated fuel
  - Sucked-in air

##### Electrical system

1. Battery
  - Discharged battery
  - Faulty battery
2. Fuse(s)
  - Blown, damaged or incorrect fuse
  - Improperly installed fuse
3. Spark plug(s)
  - Incorrect spark plug gap
  - Incorrect spark plug heat range
  - Fouled spark plug
  - Worn or damaged electrode
  - Worn or damaged insulator
4. Ignition coil(s)
  - Cracked or broken ignition coil body
  - Broken or shorted primary or secondary coils
  - Faulty spark plug lead
5. Ignition system
  - Faulty ECU
  - Faulty crankshaft position sensor
6. Switches and wiring
  - Faulty main switch
  - Faulty engine stop switch
  - Broken or shorted wiring
  - Faulty neutral switch
  - Faulty start switch
  - Faulty sidestand switch
  - Faulty clutch switch
  - Improperly grounded circuit
  - Loose connections
7. Starting system
  - Faulty starter motor
  - Faulty starter relay
  - Faulty starting circuit cut-off relay
  - Faulty starter clutch

EAS28490

#### INCORRECT ENGINE IDLING SPEED

##### Engine

1. Cylinder(s) and cylinder head(s)
  - Incorrect valve clearance
  - Damaged valve train components
2. Air filter
  - Clogged air filter element

##### Fuel system

1. Throttle body (-ies)
  - Damaged or loose throttle body joint
  - Improperly synchronized throttle bodies
  - Improper throttle cable free play
  - Flooded throttle body
  - Faulty air induction system

## TROUBLESHOOTING

### Electrical system

1. Battery
  - Discharged battery
  - Faulty battery
2. Spark plug(s)
  - Incorrect spark plug gap
  - Incorrect spark plug heat range
  - Fouled spark plug
  - Worn or damaged electrode
  - Worn or damaged insulator
3. Ignition coil(s)
  - Broken or shorted primary or secondary coils
  - Cracked or broken ignition coil
4. Ignition system
  - Faulty ECU
  - Crankshaft position sensor

EAS28520

### POOR MEDIUM-AND-HIGH-SPEED PERFORMANCE

Refer to "STARTING FAILURES" on page 9-1.

### Engine

1. Air filter
  - Clogged air filter element
  - Faulty YCC-T and YCC-I

### Fuel system

1. Fuel pump
  - Faulty fuel pump

EAS28530

### FAULTY GEAR SHIFTING

#### Shifting is difficult

Refer to "Clutch drags".

EAS28540

### SHIFT PEDAL DOES NOT MOVE

#### Shift shaft

- Improperly adjusted shift rod
- Bent shift shaft

#### Shift drum and shift forks

- Foreign object in a shift drum groove
- Seized shift fork
- Bent shift fork guide bar

#### Transmission

- Seized transmission gear
- Foreign object between transmission gears
- Improperly assembled transmission

EAS28550

### JUMPS OUT OF GEAR

#### Shift shaft

- Incorrect shift pedal position
- Improperly returned stopper lever

#### Shift forks

- Worn shift fork

#### Shift drum

- Incorrect axial play
- Worn shift drum groove

#### Transmission

- Worn gear dog

EAS28560

### FAULTY CLUTCH

#### Clutch slips

1. Clutch
  - Improperly assembled clutch
  - Improperly adjusted clutch cable
  - Loose or fatigued clutch spring
  - Worn friction plate
  - Worn clutch plate
2. Engine oil
  - Incorrect oil level
  - Incorrect oil viscosity (low)
  - Deteriorated oil

#### Clutch drags

1. Clutch
  - Unevenly tensioned clutch spring
  - Warped pressure plate
  - Bent clutch plate
  - Swollen friction plate
  - Bent clutch pull rod
  - Damaged clutch boss
  - Burnt primary driven gear bushing
  - Match marks not aligned
2. Engine oil
  - Incorrect oil level
  - Incorrect oil viscosity (high)
  - Deteriorated oil

EAS28600

### OVERHEATING

#### Engine

1. Clogged coolant passages
  - Cylinder head(s) and piston(s)
  - Heavy carbon buildup
2. Engine oil
  - Incorrect oil level

## TROUBLESHOOTING

- Incorrect oil viscosity
- Inferior oil quality

### Cooling system

1. Coolant
  - Low coolant level
2. Radiator
  - Damaged or leaking radiator
  - Faulty radiator cap
  - Bent or damaged radiator fin
3. Water pump
  - Damaged or faulty water pump
  - Thermostat
  - Thermostat stays closed
  - Clogged or damaged oil cooler
  - Damaged hose
  - Improperly connected hose
  - Damaged pipe
  - Improperly connected pipe

### Fuel system

1. Throttle body(-ies)
  - Faulty throttle body(-ies)
  - Damaged or loose throttle body joint
2. Air filter
  - Clogged air filter element

### Chassis

1. Brake(s)
  - Dragging brake

### Electrical system

1. Spark plug(s)
  - Incorrect spark plug gap
  - Incorrect spark plug heat range
2. Ignition system
  - Faulty ignitor unit

EAS28610

### OVER COOLING

#### Cooling system

1. Thermostat
  - Thermostat stays open

EAS28620

### POOR BRAKING PERFORMANCE

- Worn brake pad
- Worn brake disc
- Air in hydraulic brake system
- Leaking brake fluid
- Faulty brake caliper kit
- Faulty brake caliper seal
- Loose union bolt
- Damaged brake hose

- Oil or grease on the brake disc
- Oil or grease on the brake pad
- Incorrect brake fluid level

EAS28650

### FAULTY FRONT FORK LEGS

#### Leaking oil

- Bent, damaged or rusty inner tube
- Cracked or damaged outer tube
- Improperly installed oil seal
- Damaged oil seal lip
- Incorrect oil level (high)
- Loose damper rod assembly bolt
- Damaged damper rod assembly bolt copper washer
- Cracked or damaged cap bolt O-ring

#### Malfunction

- Bent or damaged inner tube
- Bent or damaged outer tube
- Damaged fork spring
- Worn or damaged outer tube bushing
- Bent or damaged damper rod
- Incorrect oil viscosity
- Incorrect oil level

EAS28680

### UNSTABLE HANDLING

1. Handlebar
  - Bent or improperly installed right handlebar
  - Bent or improperly installed left handlebar
2. Steering head components
  - Improperly installed upper bracket
  - Improperly installed lower bracket (improperly tightened ring nut)
  - Bent steering stem
  - Damaged ball bearing or bearing race
3. Front fork leg(s)
  - Uneven oil levels (both front fork legs)
  - Unevenly tensioned fork spring (both front fork legs)
  - Broken fork spring
  - Bent or damaged inner tube
  - Bent or damaged outer tube
4. Swingarm
  - Worn bearing or bushing
  - Bent or damaged swingarm
5. Rear shock absorber assembly(-ies)
  - Faulty rear shock absorber spring
  - Leaking oil or gas
6. Tire(s)
  - Uneven tire pressures (front and rear)
  - Incorrect tire pressure
  - Uneven tire wear

## TROUBLESHOOTING

---

### 7. Wheel(s)

- Incorrect wheel balance
- Deformed cast wheel
- Damaged wheel bearing
- Bent or loose wheel axle
- Excessive wheel runout

### 8. Frame

- Bent frame
- Damaged steering head pipe
- Improperly installed bearing race

EAS28710

### **FAULTY LIGHTING OR SIGNALING SYSTEM**

#### **Headlight does not come on**

- Wrong headlight bulb
- Too many electrical accessories
- Hard charging
- Incorrect connection
- Improperly grounded circuit
- Poor contacts (main or light switch)
- Burnt-out headlight bulb

#### **Headlight bulb burnt out**

- Wrong headlight bulb
- Faulty battery
- Faulty rectifier/regulator
- Improperly grounded circuit
- Faulty main switch
- Faulty light switch
- Headlight bulb life expired

#### **Tail/brake light does not come on**

- Too many electrical accessories
- Incorrect connection

#### **Tail/brake light bulb burnt out**

- Faulty battery
- Incorrectly adjusted rear brake light switch

#### **Turn signal does not come on**

- Faulty turn signal switch
- Faulty turn signal relay
- Burnt-out turn signal bulb
- Incorrect connection
- Damaged or faulty wire harness
- Improperly grounded circuit
- Faulty battery
- Blown, damaged or incorrect fuse

#### **Turn signal blinks slowly**

- Faulty turn signal relay
- Faulty main switch
- Faulty turn signal switch

- Incorrect turn signal bulb

#### **Turn signal remains lit**

- Faulty turn signal relay
- Burnt-out turn signal bulb

#### **Turn signal blinks quickly**

- Incorrect turn signal bulb
- Faulty turn signal relay
- Burnt-out turn signal bulb

#### **Horn does not sound**

- Improperly adjusted horn
- Damaged or faulty horn
- Faulty main switch
- Faulty horn switch
- Faulty battery
- Blown, damaged or incorrect fuse
- Faulty wire harness

EAS28740

## WIRING DIAGRAM

### YZF-R1(W) 2007

1. Main switch
2. AC magneto
3. Rectifier/regulator
4. Main fuse
5. Backup fuse
6. Immobilizer unit
7. ETV fuse
8. Battery
9. Fuel injection system fuse
10. Starter relay
11. Starter motor
12. Starting circuit cut-off relay
13. Neutral switch
14. Sidestand switch
15. Fuel pump
16. Throttle position sensor (for throttle valves)
17. Throttle position sensor (for throttle cable pulley)
18. O<sub>2</sub> sensor
19. ECU (engine control unit)
20. Ignition coil #1
21. Ignition coil #2
22. Ignition coil #3
23. Ignition coil #4
24. Spark plug
25. Injector #1
26. Injector #2
27. Injector #3
28. Injector #4
29. Air induction system solenoid
30. Intake funnel servo motor
31. Throttle servo motor
32. EXUP servo motor
33. Speed sensor
34. Intake air temperature sensor
35. Crankshaft position sensor
36. Coolant temperature sensor
37. Intake air pressure sensor
38. Atmospheric pressure sensor
39. Cylinder identification sensor
40. Lean angle sensor
41. Meter assembly
42. Immobilizer system indicator light
43. Fuel level warning light
44. Oil level warning light
45. Neutral indicator light
46. Tachometer
47. Shift timing indicator light
48. Multi-function meter
49. Engine trouble warning light
50. Coolant temperature indicator light
51. High beam indicator light
52. Left turn signal indicator light
53. Right turn signal indicator light

54. Meter light
55. Oil level switch
56. Right handlebar switch
57. Front brake light switch
58. Engine stop switch
59. Start switch
60. Turn signal/hazard relay
61. Left handlebar switch
62. Hazard switch
63. Pass switch
64. Dimmer switch
65. Horn switch
66. Clutch switch
67. Turn signal switch
68. Horn
69. Front left turn signal light
70. Front right turn signal light
71. Rear left turn signal light
72. Rear right turn signal light
73. Headlight
74. Auxiliary light
75. Ground (cord head light)
76. License plate light
77. Rear brake light switch
78. Tail/brake light
79. Headlight relay (on/off)
80. Headlight relay (dimmer)
81. Ignition fuse
82. Turn signal light fuse
83. Signal fuse
84. Headlight fuse
85. Anti-theft alarm
86. Radiator fan motor relay
87. Right radiator fan motor fuse
88. Left radiator fan motor fuse
89. Right radiator fan motor
90. Left radiator fan motor
91. Ground
92. Battery negative lead

B/W	Black/White
B/Y	Black/Yellow
Br/G	Brown/Green
Br/L	Brown/Blue
Br/R	Brown/Red
Br/W	Brown/White
G/B	Green/Black
G/W	Green/White
G/Y	Green/Yellow
Gy/G	Gray/Green
Gy/R	Gray/Red
L/B	Blue/Black
L/R	Blue/Red
L/W	Blue/White
L/Y	Blue/Yellow
Lg/R	Light green/Red
O/B	Orange/Black
O/G	Orange/Green
P/B	Pink/Black
P/W	Pink/White
R/B	Red/Black
R/G	Red/Green
R/L	Red/Blue
R/W	Red/White
R/Y	Red/Yellow
Sb/W	Sky blue/White
W/B	White/Black
W/L	White/Blue
W/R	White/Red
W/Y	White/Yellow
Y/R	Yellow/Red
Y/B	Yellow/Black
Y/G	Yellow/Green
Y/L	Yellow/Blue

EAS28750

## COLOR CODE

B	Black
Br	Brown
Ch	Chocolate
Dg	Dark green
G	Green
Gy	Gray
L	Blue
Lg	Light green
O	Orange
P	Pink
R	Red
Sb	Sky blue
W	White
Y	Yellow
B/G	Black/Green
B/L	Black/Blue
B/R	Black/Red





### YZF-R1(W) 2007 WIRING DIAGRAM

### YZF-R1(W) 2007 SCHEMA DE CABLAGE

### YZF-R1(W) 2007 SCHALTPLAN

### YZF-R1(W) 2007 SCHEMA ELETTRICO

### DIAGRAMA DE CONEXIONES DE YZF-R1(W) 2007

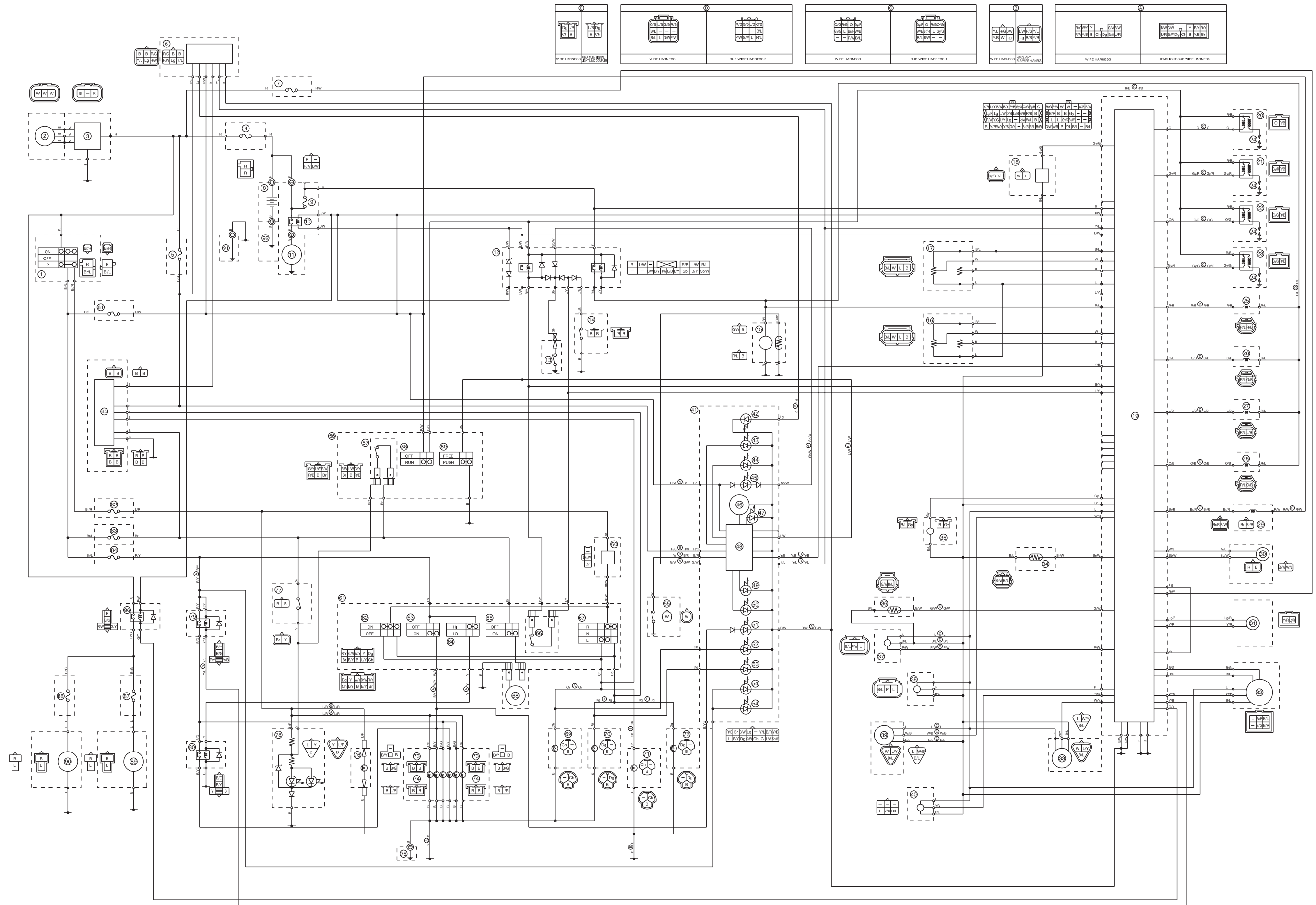

**YZF-R1(W) 2007  
WIRING DIAGRAM**

**YZF-R1(W) 2007  
SCHEMA DE CABLAGE**

**YZF-R1(W) 2007  
SCHALTPLAN**

**YZF-R1(W) 2007  
SCHEMA ELETTRICO**

**DIAGRAMA DE CONEXIONES  
DE YZF-R1(W) 2007**

