



YAMAHA

2007

MOTOMATRIX

**XT660R(W)
XT660X(W)**

**SUPPLEMENTARY
SERVICE MANUAL**

5VK-F8197-E2

FOREWORD

This Supplementary Service Manual has been prepared to introduce new service and data for the XT660R(W)/XT660X(W) 2007. For complete service information procedures it is necessary to use this Supplementary Service Manual together with the following manual.

XT660R(S)/XT660X(S) 2004 SERVICE MANUAL: 5VK1-AE1

**XT660R(W)/XT660X(W) 2007
SUPPLEMENTARY
SERVICE MANUAL
©2006 by MBK Industrie
First edition, July 2006
All rights reserved.
Any reproduction or unauthorized use
without the written permission of
MBK Industrie
is expressly prohibited.**

EAS00002

NOTICE

This manual was produced by MBK Industrie primarily for use by Yamaha dealers and their qualified mechanics. It is not possible to include all the knowledge of a mechanic in one manual. Therefore, anyone who uses this book to perform maintenance and repairs on Yamaha vehicles should have a basic understanding of mechanics and the techniques to repair these types of vehicles. Repair and maintenance work attempted by anyone without this knowledge is likely to render the vehicle unsafe and unfit for use.

Yamaha is continually striving to improve all its models. Modifications and significant changes in specifications or procedures will be forwarded to all authorized Yamaha dealers and will appear in future editions of this manual where applicable.

NOTE:

Designs and specifications are subject to change without notice.

EAS00004

IMPORTANT MANUAL INFORMATION

Particularly important information is distinguished in this manual by the following.



The Safety Alert Symbol means ATTENTION! BECOME ALERT! YOUR SAFETY IS INVOLVED!



Failure to follow WARNING instructions could result in severe injury or death to the motorcycle operator, a bystander or a person checking or repairing the motorcycle.

CAUTION:

A CAUTION indicates special precautions that must be taken to avoid damage to the motorcycle.

NOTE:

A NOTE provides key information to make procedures easier or clearer.

EAS00007

HOW TO USE THIS MANUAL

This manual is intended as a handy, easy-to-read reference book for the mechanic. Comprehensive explanations of all installation, removal, disassembly, assembly, repair and check procedures are laid out with the individual steps in sequential order.

- ① The manual is divided into chapters. An abbreviation and symbol in the upper right corner of each page indicate the current chapter. Refer to "SYMBOLS".
- ② Each chapter is divided into sections. The current section title is shown at the top of each page, except in Chapter 3 ("PERIODIC CHECKS AND ADJUSTMENTS"), where the sub-section title(s) appears.
- ③ Sub-section titles appear in smaller print than the section title.
- ④ To help identify parts and clarify procedure steps, there are exploded diagrams at the start of each removal and disassembly section.
- ⑤ Numbers are given in the order of the jobs in the exploded diagram. A circled number indicates a disassembly step.
- ⑥ Symbols indicate parts to be lubricated or replaced. Refer to "SYMBOLS".
- ⑦ A job instruction chart accompanies the exploded diagram, providing the order of jobs, names of parts, notes in jobs, etc.
- ⑧ Jobs requiring more information (such as special tools and technical data) are described sequentially.

② ①

CLUTCH ENG

EAS00074

CLUTCH

④

⑤

⑥

⑦

Order	Job/Part	Qty	Remarks	
Removing the clutch				
1	Clutch spring	5	Remove the parts in the order listed.	
2	Pressure plate	1		
3	Pull rod	1		
4	Friction plate 1	4		Inside diameter (plate with notched tabs) = 119 mm (4.69 in)
5	Clutch plate	6		Refer to "INSTALLING THE CLUTCH".
6	Friction plate 2	2		
7	Friction plate 3	1		Inside diameter (plate with notched tabs) = 128 mm (5.04 in)
8	Clutch damper spring	1		
9	Clutch damper spring seat	1		

5 - 42

CLUTCH ENG

EAS00075

REMOVING THE CLUTCH

③

⑧

1. Remove:
 - clutch cover ①

NOTE:
Loosen each bolt 1/4 of a turn at a time, in stages and in a crisscross pattern. After all of the bolts are fully loosened, remove them.

2. Straighten the lock washer tab.
3. Loosen:
 - clutch boss nut ②

NOTE:
While holding the clutch boss ② with the universal clutch holder ③, loosen the clutch boss nut.

















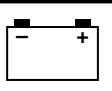

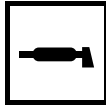

Universal clutch holder
90890-04086

4. Remove:
 - lock washer
 - clutch boss

CHECKING THE FRICTION PLATES
The following procedure applies to all of the friction plates.

1. Check:
 - friction plate 1
 - friction plate 2
 - friction plate 3
 Damage/wear → Replace the friction plates as a set.

5 - 44

① GEN INFO 	② SPEC 
③ CHK ADJ 	④ CHAS 
⑤ ENG 	⑥ COOL 
⑦ FI 	⑧ ELEC 
⑨ TRBL SHTG ?	⑩ 
⑪ 	⑫ 
⑬ 	⑭ 
⑮  ⑯  ⑰ 	
⑱  ⑲  ⑳ 	
㉑  ㉒  ㉓ 	
㉔ 	㉕ New

EAS00008

SYMBOLS

The following symbols are not relevant to every vehicle.

Symbols ① to ⑨ indicate the subject of each chapter.

- ① General information
- ② Specifications
- ③ Periodic checks and adjustments
- ④ Chassis
- ⑤ Engine
- ⑥ Cooling system
- ⑦ Fuel injection system
- ⑧ Electrical system
- ⑨ Troubleshooting

Symbols ⑩ to ⑰ indicate the following.

- ⑩ Serviceable with engine mounted
- ⑪ Filling fluid
- ⑫ Lubricant
- ⑬ Special tool
- ⑭ Tightening torque
- ⑮ Wear limit, clearance
- ⑯ Engine speed
- ⑰ Electrical data

Symbols ⑱ to ㉓ in the exploded diagrams indicate the types of lubricants and lubrication points.

- ⑱ Engine oil
- ⑲ Gear oil
- ⑳ Molybdenum-disulfide oil
- ㉑ Wheel-bearing grease
- ㉒ Lithium-soap-based grease
- ㉓ Molybdenum-disulfide grease

Symbols ㉔ to ㉕ in the exploded diagrams indicate the following.

- ㉔ Apply locking agent (LOCTITE®)
- ㉕ Replace the part

CONTENTS

SPECIFICATIONS	1
GENERAL SPECIFICATIONS	1
ENGINE SPECIFICATIONS.....	2
CHASSIS SPECIFICATIONS.....	6
ELECTRICAL SPECIFICATIONS	8
TIGHTENING TORQUE	8
ENGINE TIGHTENING TORQUES	8
CHASSIS TIGHTENING TORQUES	8
CABLE ROUTING	9
PERIODIC CHECKS AND ADJUSTMENTS	22
COWLING AND COVER.....	22
COVER	22
COWLING	23
FUEL TANK.....	24
CHASSIS.....	26
ADJUSTING THE DRIVE CHAIN SLACK.....	26
CHECKING THE TIRES	28
CHASSIS	32
REAR WHEEL, BRAKE DISC, AND REAR WHEEL SPROCKET	32
REAR WHEEL	32
REMOVING THE REAR WHEEL (XT660R)	34
REMOVING THE REAR WHEEL (XT660X)	35
INSTALLING THE REAR WHEEL (XT660R).....	35
INSTALLING THE REAR WHEEL (XT660X).....	36
SWINGARM AND DRIVE CHAIN.....	38
ENGINE	41
ENGINE REMOVAL	41
EXHAUST PIPES AND MUFFLERS.....	41
CYLINDER HEAD	42
CYLINDER AND PISTON	44
COOLING SYSTEM	46
RADIATOR.....	46
FUEL INJECTION SYSTEM	48
FUEL INJECTION SYSTEM.....	48
WIRING DIAGRAM	49
FAIL-SAFE ACTION TABLE	50
DIAGNOSTIC MODE	52
TROUBLESHOOTING DETAILS	58
ELECTRICAL SYSTEM	71
ELECTRICAL COMPONENTS.....	71

XT660R(W)/XT660X(W) 2007 WIRING DIAGRAM

GENERAL SPECIFICATIONS**SPEC****SPECIFICATIONS****GENERAL SPECIFICATIONS**

Item	Standard	Limit
Model code	XT660R: 5VK8 (Europe)	----
	5VK9 (AUS)	----
	XT660X: 10S1 (Europe)	----
	10S2 (AUS)	----
Dimensions		
Overall length	2,240 mm (88.2 in) (XT660R)	----
	2,175 mm (85.6 in) (XT660X)	----
Overall width	845 mm (33.3 in) (XT660R)	----
	860 mm (33.9 in) (XT660X)	----
Overall height	1,230 mm (48.4 in) (XT660R)	----
	1,170 mm (46.1 in) (XT660X)	----
Seat height	865 mm (34.1 in) (XT660R)	----
	875 mm (34.4 in) (XT660X)	----
Wheelbase	1,505 mm (59.3 in) (XT660R)	----
	1,490 mm (58.7 in) (XT660X)	----
Minimum ground clearance	210 mm (8.27 in) (XT660R)	----
	205 mm (8.07 in) (XT660X)	----
Minimum turning radius	2,400 mm (94.5 in)	----

ENGINE SPECIFICATIONS



ENGINE SPECIFICATIONS

Item	Standard	Limit
Engine		
Engine type	Liquid-cooled, 4-stroke, SOHC	----
Displacement	660 cm ³	----
Cylinder arrangement	Forward-inclined single cylinder	----
Bore × stroke	100.0 × 84.0 mm (3.94 × 3.31 in)	----
Compression ratio	10.00 : 1	----
Engine idling speed	1,400 ~ 1,500 r/min	----
Water temperature	80 °C (176 °F)	----
Oil temperature	55 ~ 65 °C (131 ~ 149 °F)	----
Standard compression pressure (at sea level)	650 kPa (6.5 kg/cm ² , 92.4 psi) at 800 r/min	----
Engine oil		
Lubrication system	Dry sump	----
Recommended oil	SAE 10W30, SAE 10W-40, SAE 15W40, SAE 20W40 or SAE 20W-50 Refer to the chart for engine oil grade.	----
Recommended engine oil grade	API service SG type or higher, JASO standard MA	----
Quantity		
Total amount	2.90 L (2.55 Imp qt, 3.07 US qt)	----
Periodic oil change	2.50 L (2.20 Imp qt, 2.64 US qt)	----
With oil filter replacement	2.60 L (2.29 Imp qt, 2.75 US qt)	----
Oil pump		
Oil pump type	Trochoid	----
Inner-rotor-to-outer-rotor-tip clearance	0.03 ~ 0.08 mm (0.0012 ~ 0.0031 in)	0.16 mm (0.0063 in)
Outer-rotor-to-oil-pump-housing clearance	0.09 ~ 0.15 mm (0.0035 ~ 0.0059 in)	0.22 mm (0.0087 in)
Oil-pump-housing-to-inner-rotor-and-outer-rotor clearance	0.03 ~ 0.08 mm (0.0012 ~ 0.0031 in)	0.15 mm (0.0059 in)

ENGINE SPECIFICATIONS

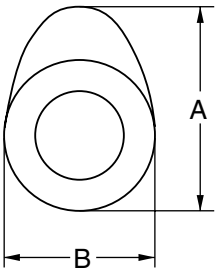
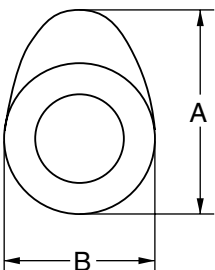
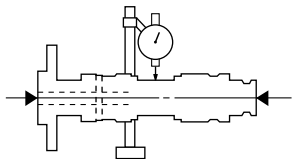

Item	Standard	Limit
Camshaft		
Drive system	Chain drive (left)	----
Intake camshaft lobe dimensions		
		
Measurement A	43.488 ~ 43.588 mm (1.7121 ~ 1.7161 in)	43.388 mm (1.7082 in)
Measurement B	36.959 ~ 37.059 mm (1.4551 ~ 1.4590 in)	36.859 mm (1.4511 in)
Exhaust camshaft lobe dimensions		
		
Measurement A	43.129 ~ 43.229 mm (1.6980 ~ 1.7019 in)	43.029 mm (1.6941 in)
Measurement B	37.007 ~ 37.107 mm (1.4570 ~ 1.4609 in)	36.907 mm (1.4530 in)
Valve timing		
Intake - open (B.T.D.C.)	25°	----
Intake - closed (A.B.D.C.)	55°	----
Exhaust - open (B.B.D.C.)	60°	----
Exhaust - closed (A.T.D.C.)	20°	----
Overlap angle "A"	45°	----
Maximum camshaft runout	----	0.040 mm (0.0016 in)
		
Timing chain		
Model/number of links	98XRH2010/126	----
Tensioning system	Automatic	----

ENGINE SPECIFICATIONS

SPEC



Item	Standard	Limit
Piston		
Piston-to-cylinder clearance	0.030 ~ 0.055 mm (0.0012 ~ 0.0022 in)	0.13 mm (0.0051 in)
Diameter D	99.955 ~ 99.970 mm (3.9352 ~ 3.9358 in)	----
Height H	10.0 mm (0.39 in)	----
Piston pin bore (in the piston)		
Diameter	23.004 ~ 23.015 mm (0.9057 ~ 0.9061 in)	23.045 mm (0.9073 in)
Offset	0.50 mm (0.0197 in)	----
Offset direction	Intake side	----
Piston pin		
Outside diameter	22.991 ~ 23.000 (0.9052 ~ 0.9055 in)	22.971 mm (0.9044 in)
Piston-pin-to-piston-pin-bore clearance	0.004 ~ 0.024 mm (0.0002 ~ 0.0009 in)	0.074 mm (0.0029 in)
Piston rings		
Top ring		
Ring type	Barrel	----
Dimensions (B × T)	1.20 × 3.80 mm (0.047 × 0.150 in)	----
End gap (installed)	0.20 ~ 0.35 mm (0.0079 ~ 0.0138 in)	0.60 mm (0.0236 in)
Ring side clearance	0.030 ~ 0.080 mm (0.0012 ~ 0.0031 in)	0.13 mm (0.0051 in)
2nd ring		
Ring type	Taper	----
Dimensions (B × T)	1.20 × 4.00 mm (0.047 × 0.157 in)	----
End gap (installed)	0.35 ~ 0.50 mm (0.0138 ~ 0.0197 in)	0.85 mm (0.0335 in)
Ring side clearance	0.030 ~ 0.070 mm (0.0012 ~ 0.0028 in)	0.13 mm (0.0051 in)

ENGINE SPECIFICATIONS

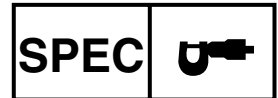

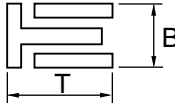
Item	Standard	Limit
<p>Oil ring</p>  <p>Dimensions (B × T)</p> <p>End gap (installed)</p> <p>Ring side clearance</p>	<p>2.50 × 3.40 mm (0.098 × 0.134 in)</p> <p>0.20 ~ 0.70 mm (0.0079 ~ 0.0276 in)</p> <p>0.060 ~ 0.150 mm (0.0024 ~ 0.0059 in)</p>	<p>----</p> <p>----</p> <p>----</p>
<p>Throttle body</p> <p>Model/manufacturer × quantity</p> <p>Intake vacuum pressure</p> <p>Throttle cable free play (at the flange of the throttle grip)</p> <p>ID mark</p> <p>Throttle valve size</p>	<p>44EHS/MIKUNI × 1</p> <p>37.6 ~ 40.2 kPa (282 ~ 302 mmHg, 11.1 ~ 11.9 inHg)</p> <p>3.0 ~ 5.0 mm (0.12 in ~ 0.20 mm)</p> <p>5VK8 10</p> <p>#50</p>	<p>----</p> <p>----</p> <p>----</p> <p>----</p> <p>----</p>

CHASSIS SPECIFICATIONS**SPEC****CHASSIS SPECIFICATIONS**

Item	Standard	Limit
Rear wheel		
Wheel type	Spoke wheel	----
Rim		
Size	17M/C × MT2.75 (XT660R)	----
	17M/C × MT4.25 (XT660X)	----
Material	Aluminum	----
Wheel travel	200.0 mm (7.87 in) (XT660R)	----
	191.0 mm (7.52 in) (XT660X)	----
Wheel runout		
Maximum radial wheel runout	----	2.0 mm (0.08 in)
Maximum lateral wheel runout	----	2.0 mm (0.08 in)
Wheel axle bending limit	----	0.25 mm (0.01 in)
Front tire		
Tire type	With tube	----
Size	90/90-21M/C 54S, 90/90-21M/C 54T (XT660R)	----
	120/70R 17M/C 58 H, 120/70ZR 17M/C 58W, 120/70ZR 17M/C 58W (XT660X)	----
Model/manufacturer	TOURANCE FRONT/METZELER, SIRAC/MICHELIN (XT660R)	----
	DRAGON/PIRELLI, SPORTEC M1/ METZELER, RADIAL PILOT SPORT/ MICHELIN (XT660X)	----
Tire pressure (cold)		
0 ~ 90 kg (0 ~ 198 lb)	200 kPa (2.00 kgf/cm, 29 psi) (XT660R)	----
	210 kPa (2.10 kgf/cm, 30 psi) (XT660X)	----
90 (198 lb) ~ Maximum load*	200 kPa (2.00 kgf/cm, 29 psi) (XT660R)	----
	220 kPa (2.20 kgf/cm, 31 psi) (XT660X)	----
	* Load is the total weight of the cargo, rider, passenger and accessories.	
Off-road riding	200 kPa (2.00 kgf/cm, 29 psi) (XT660R)	----
Minimum tire tread depth	----	1.6 mm (0.063 in)

CHASSIS SPECIFICATIONS



Item	Standard	Limit
Rear tire		
Tire type	With tube	----
Size	130/80-17M/C 65S, 130/80-17M/C 65T (XT660R)	----
	160/60R 17M/C 69H, 160/60ZR 17M/C 69W, 160/60ZR 17M/C 69W (XT660X)	----
Model/manufacture	TOURANCE/METZELER, SIRAC A/MICHELIN (XT660R)	----
	DRAGON/PIRELLI, SPORTEC M1/METZELER, RADIAL PILOT SPORT/MICHELIN (XT660X)	----
Tire pressure (cold)		
0 ~ 90 kg (0 ~ 198 lb)	200 kPa (2.00 kgf/cm, 29 psi) (XT660R)	----
	210 kPa (2.10 kgf/cm, 30 psi) (XT660X)	----
90 (198 lb) ~ Maximum load*	225 kPa (2.25 kgf/cm, 33 psi) (XT660R)	----
	230 kPa (2.30 kgf/cm, 33 psi) (XT660X)	----
	* Load is the total weight of the cargo, rider, passenger and accessories.	
Off-road riding	200 kPa (2.00 kgf/cm, 29 psi) (XT660R)	----
Minimum tire tread depth	----	1.6 mm (0.063 in)

**ELECTRICAL SPECIFICATIONS/
TIGHTENING TORQUE**



ELECTRICAL SPECIFICATIONS

Item	Standard	Limit
System voltage	12 V	----
Ignition system		
Ignition system type	Transistorized coil ignition (digital)	----
Ignition timing	5.0° BTDC at 1,450 r/min	----
Advancer type	Electric	----
Crankshaft position sensor resistance/ color	192 ~ 288 Ω at 20 °C (68 °F) blue/yellow–green/white	----
Transistorized coil ignition unit model/manufacture	TBDF36/DENSO	----

TIGHTENING TORQUE

ENGINE TIGHTENING TORQUES

Part to be tightened	Part name	Thread size	Q'ty	Tightening torque			Remarks
				Nm	m · kg	ft · lb	
O ₂ sensor	—	M18	1	45	4.5	32	
O ₂ sensor protector	Bolt	M6	2	10	1.0	7.2	

CHASSIS TIGHTENING TORQUES

Part to be tightened	Thread size	Tightening torque			Remarks
		Nm	m · kg	ft · lb	
Engine mounting:					
Engine upper bracket and frame	M10	65	6.5	47	
Engine front bracket and frame	M10	65	6.5	47	
Engine front bracket and engine	M10	65	6.5	47	
Engine and frame	M10	65	6.5	47	



EAS00035

CABLE ROUTING

- ① Front turn signal light lead (right)
- ② Meter assembly lead
- ③ Auxiliary light lead
- ④ Front turn signal light lead (left)
- ⑤ Headlight lead
- ⑥ Sub-wire harness

- [A] Fasten the sub-wire harness and meter assembly lead with a plastic band. Fasten the sub-wire harness at the white tape. Face the end of the plastic band forward.
- [B] Make sure that there is no slack in the meter assembly lead between the meter assembly and the plastic band. The rubber boot on the meter assembly can be bent as shown.

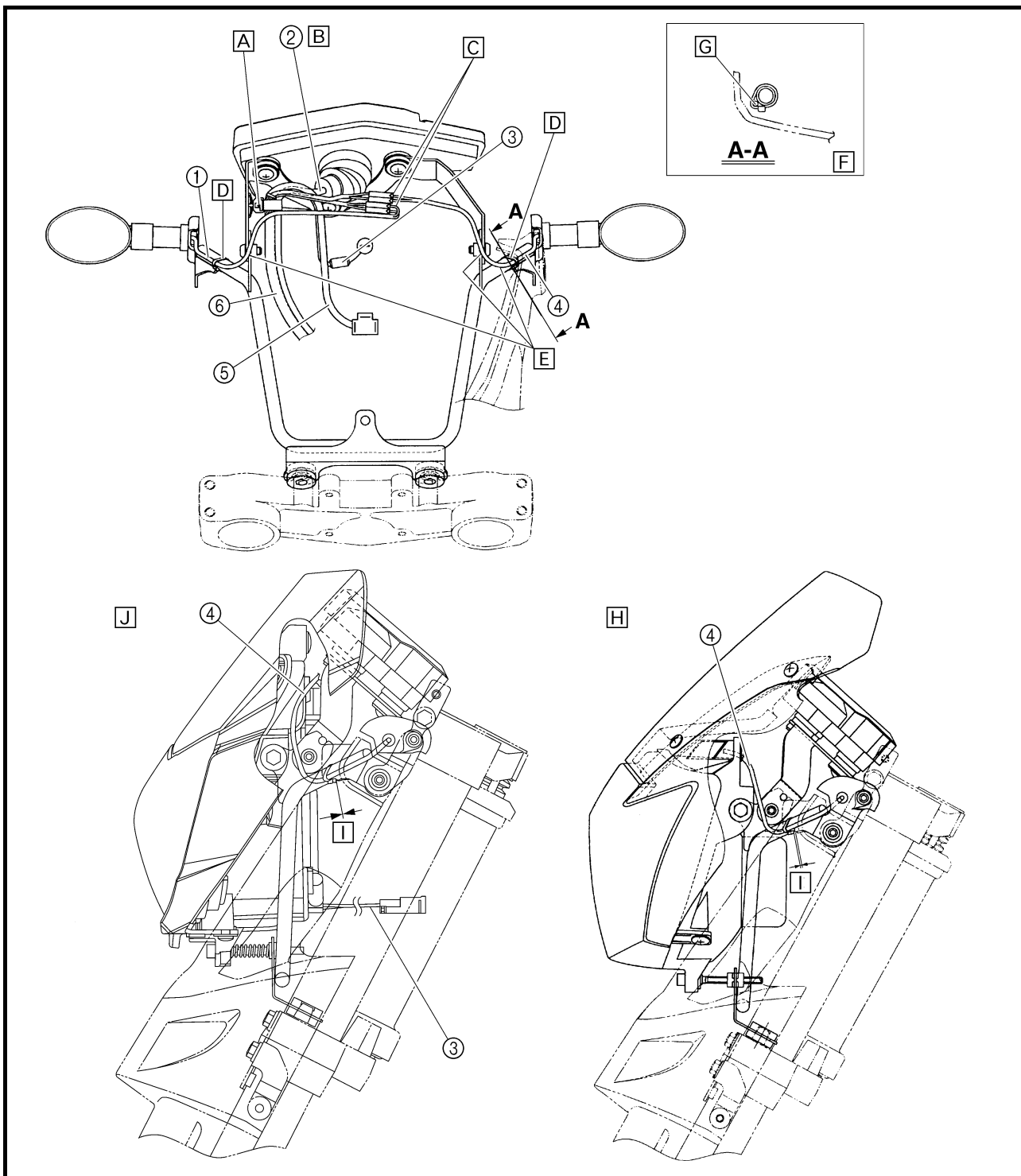

CABLE ROUTING



- C** Place the slack of the left and right front turn signal light leads between the headlight assembly and front cowling assembly.
- D** Fasten the left and right front turn signal light leads to the headlight stay with a plastic locking tie, and then cut off the excess end of tie.
- E** Pass the left and right front turn signal light leads in front of the headlight stay.
- F** Only the left side is shown in this illustration. Route the right front turn signal light lead in the same way.
- G** Pass the left and right front turn signal light leads between the headlight stay and front fork protector.
- H** XT660R
- I** 0 ~ 5 mm (0 ~ 0.20 in) for both left and right sides
- J** XT660X

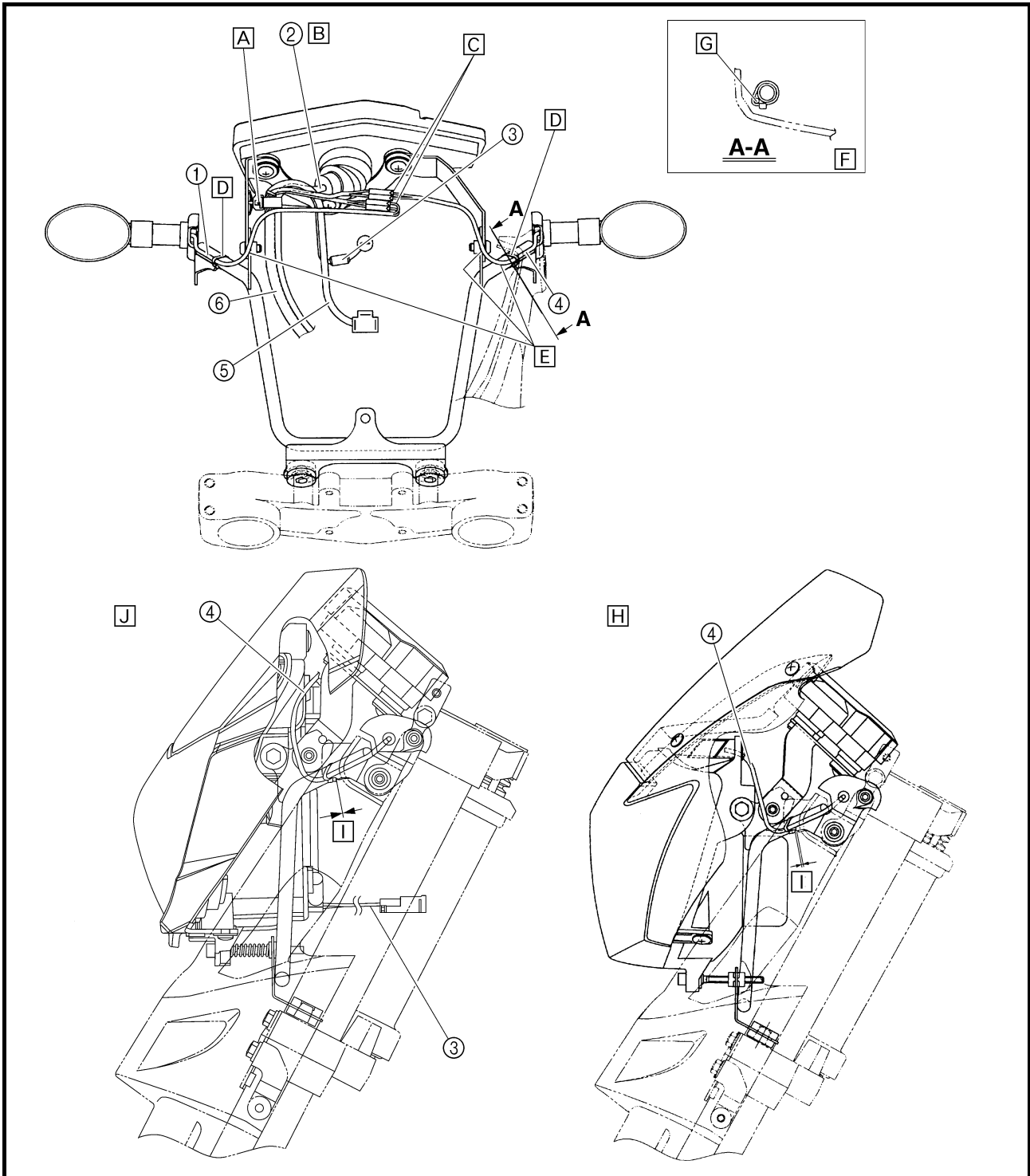

CABLE ROUTING

SPEC



- ① Rear brake light switch lead
- ② Negative battery lead
- ③ Lean angle cut-off switch lead
- ④ Throttle position sensor lead
- ⑤ Coolant temperature sensor lead
- ⑥ Turn signal/hazard relay
- ⑦ Headlight relay
- ⑧ Radiator fan motor relay
- ⑨ Relay unit

- A Fasten the wire harness and negative battery lead to the frame with a plastic locking tie.
- B Fasten the wire harness, negative battery lead, and rear brake light switch lead to the frame with a plastic locking tie.
- C Fasten the rear brake light switch lead to the frame with a plastic locking tie.
- D Fasten the wire harness to the frame at the white tape with a plastic locking tie.

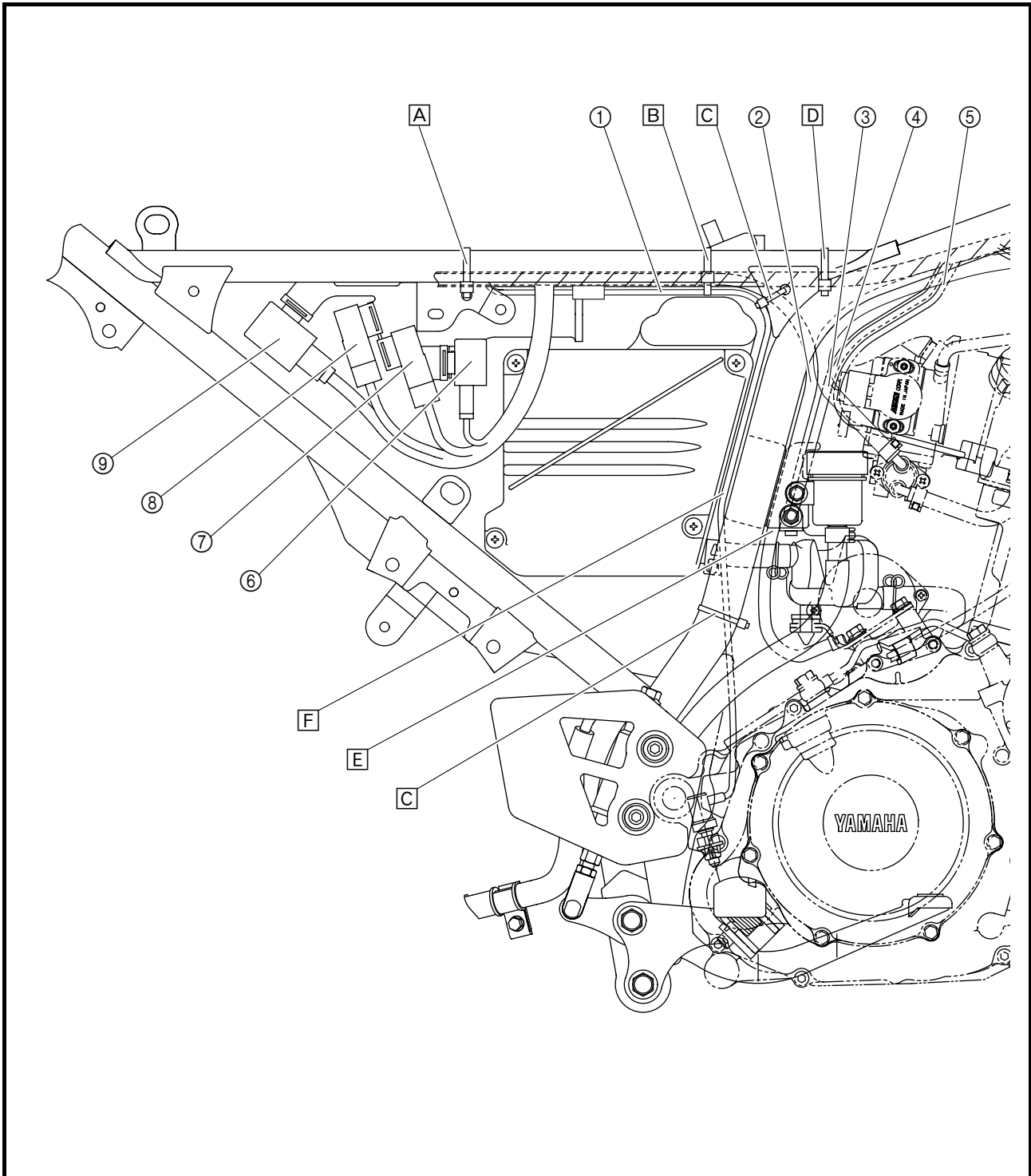

CABLE ROUTING

SPEC



- E Route the negative battery lead behind the lean angle cut-off switch bracket.
- F Route the rear brake light switch lead between the air filter case and the frame.

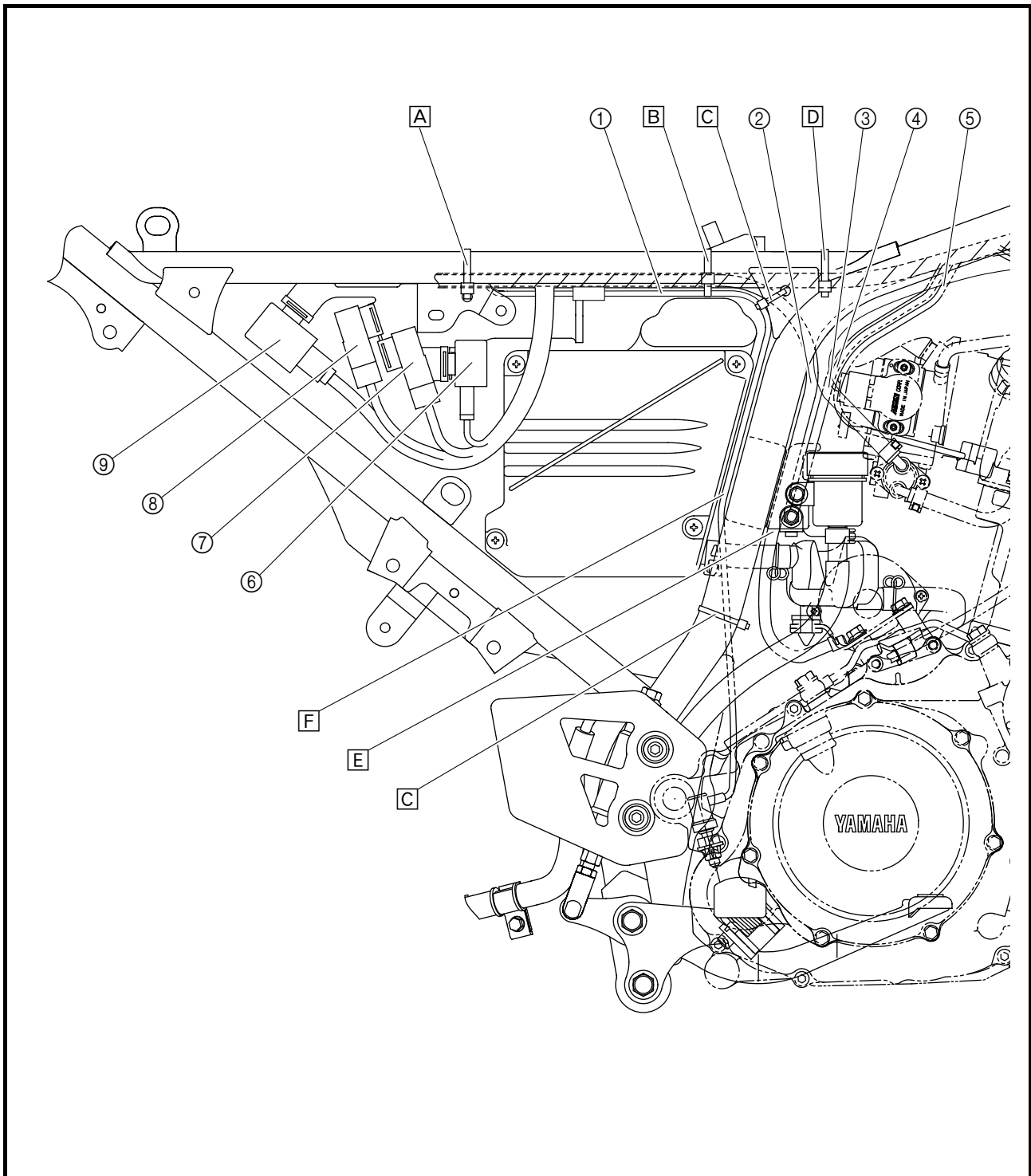

CABLE ROUTING

SPEC



- | | | |
|--------------------------------------|---------------------------------|--|
| ① Neutral switch connector | ⑩ A.C. magneto lead | ⑳ Immobilizer unit lead |
| ② Crankshaft position sensor coupler | ⑪ Oil tank breather hose | ㉑ Clutch cable |
| ③ A.C. magneto coupler | ⑫ Oil delivery hose 2 | ㉒ Main switch lead |
| ④ Speed sensor lead | ⑬ Radiator fan motor lead | ㉓ O ₂ sensor lead |
| ⑤ Intake air temperature sensor lead | ⑭ Throttle cable | ㉔ Air-filter-to-air-cut-off-valve hose |
| ⑥ ECU lead | ⑮ Headlight lead | ㉕ Wire harness |
| ⑦ Starter motor lead | ⑯ Meter assembly lead | |
| ⑧ Sidestand switch lead | ⑰ Left handlebar switch lead | |
| ⑨ Speed sensor | ⑱ Right handlebar switch lead | |
| | ⑲ Front brake light switch lead | |
| | ⑳ Clutch switch lead | |

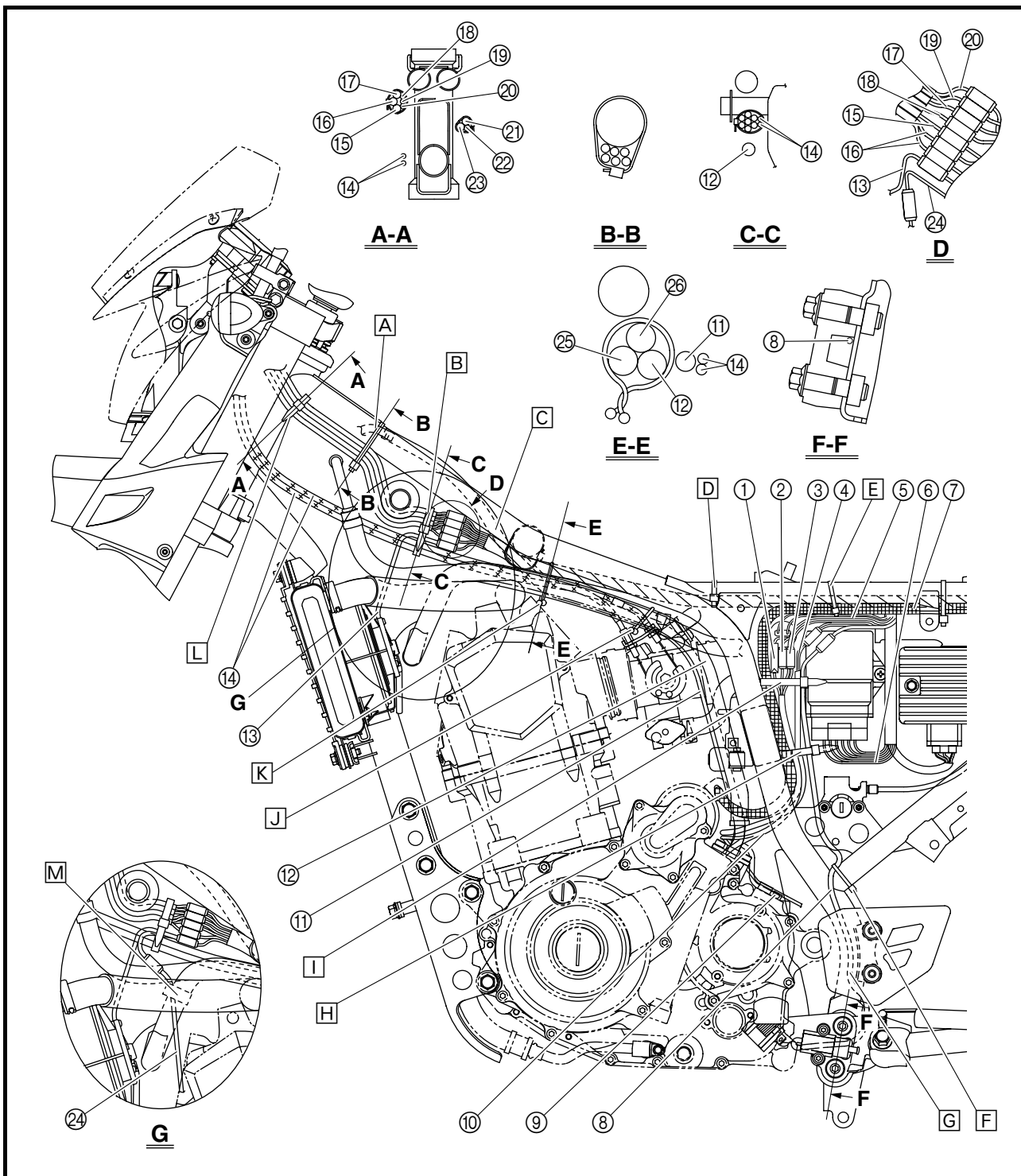

CABLE ROUTING

SPEC



A Fasten the left handlebar switch lead, right handlebar switch lead, headlight lead, meter assembly lead, front brake light switch lead, and clutch switch lead to the frame with a plastic locking tie. To fasten the leads, connect the couplers, and then turn the handlebar completely to the right.

B Fasten the left handlebar switch lead, right handlebar switch lead, headlight lead, meter assembly lead, front brake light switch lead, clutch switch lead, radiator fan motor lead, and throttle cables with a plastic band. To fasten the leads and cables, connect the couplers, and then turn the handlebar completely to the right.

C Route the oil tank breather hose on the outside of the throttle cables.

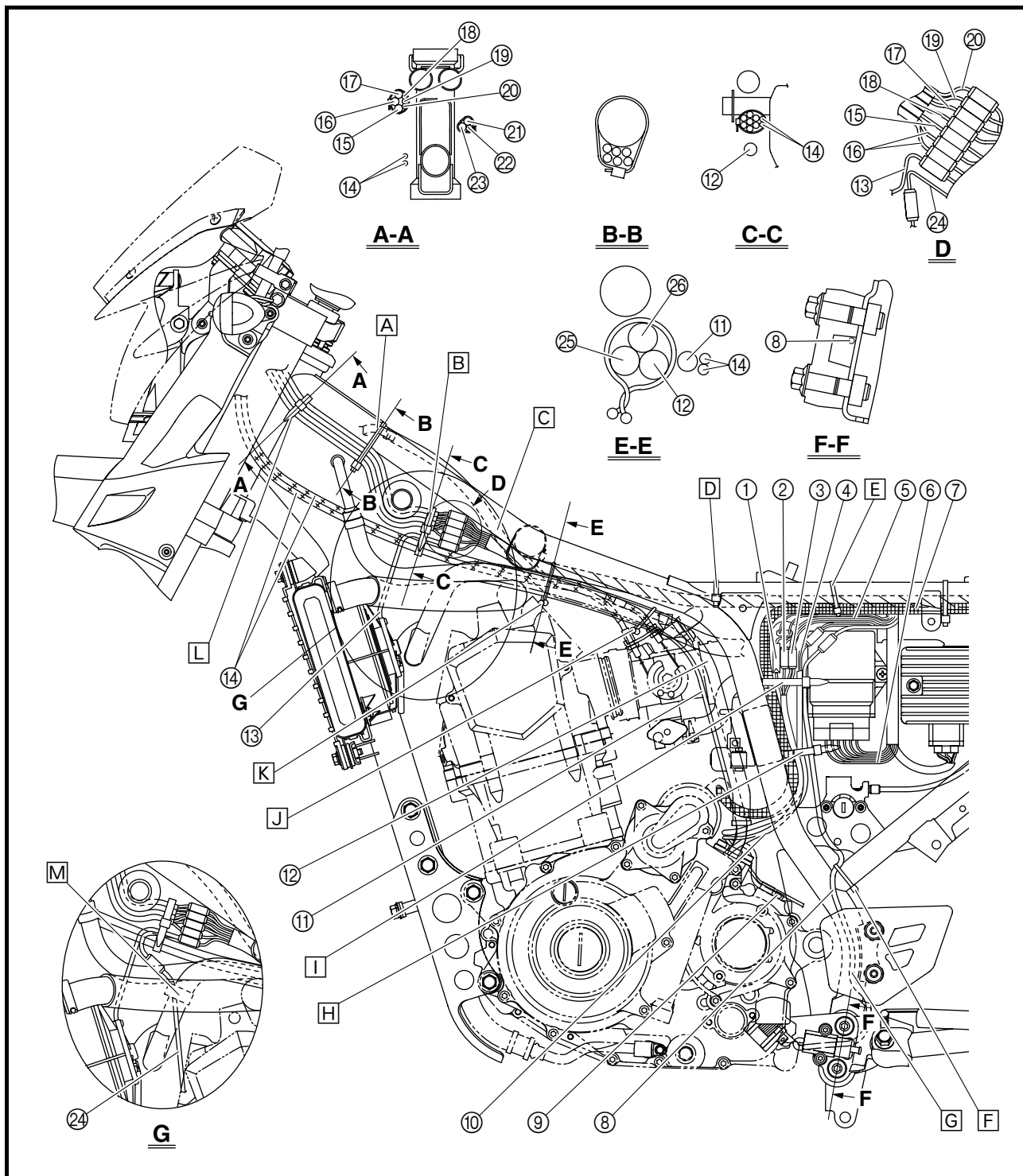

CABLE ROUTING

SPEC



- D** Fasten the wire harness to the frame at the white tape with a plastic locking tie.
- E** Fasten the starter motor lead to the frame with a plastic locking tie.
- F** Fasten the sidestand switch lead to the frame with a plastic locking tie.
- G** Route the sidestand switch lead at the front end of the left side heel plate.
- H** Fasten the neutral switch lead, crankshaft position sensor lead, sidestand switch lead, speed sensor lead, starter motor lead, and A.C. magneto lead with a plastic band.
- I** Fasten the neutral switch lead, crankshaft position sensor lead, sidestand switch lead, speed sensor lead, and starter motor lead with a plastic band.
- J** Fasten the air-filter-to-air-cut-off-valve hose, oil tank breather hose, and oil delivery hose 2 with a plastic clamp.

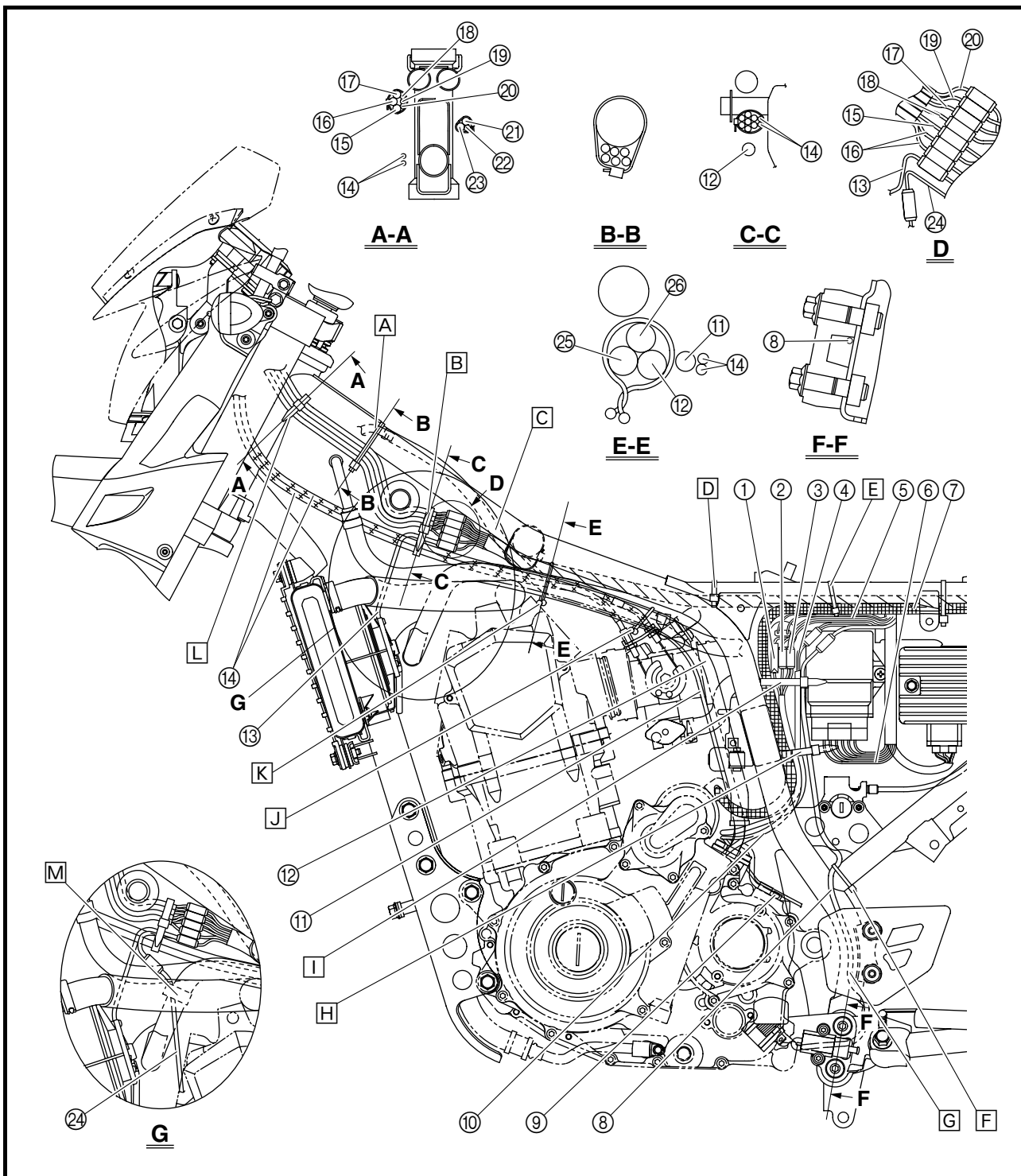

CABLE ROUTING

SPEC



- K** Fasten the wire harness, air-filter-to-air-cut-off-valve hose, and oil delivery hose 2 with a plastic clamp.
- L** Fasten the left handlebar switch lead, right handlebar switch lead, headlight lead, meter assembly lead, front brake light switch lead, and clutch switch lead with a plastic band.

Turn the handlebar completely to the right, and then fasten the left handlebar switch lead, right handlebar switch lead, headlight lead, meter assembly lead, front brake light switch lead, and clutch switch lead next to the steering head pipe with the plastic band. Be sure to connect the couplers before fastening the leads.

- M** Fasten the O₂ sensor lead and air-filter-to-air-cut-off-valve hose with a holder as shown in the illustration.

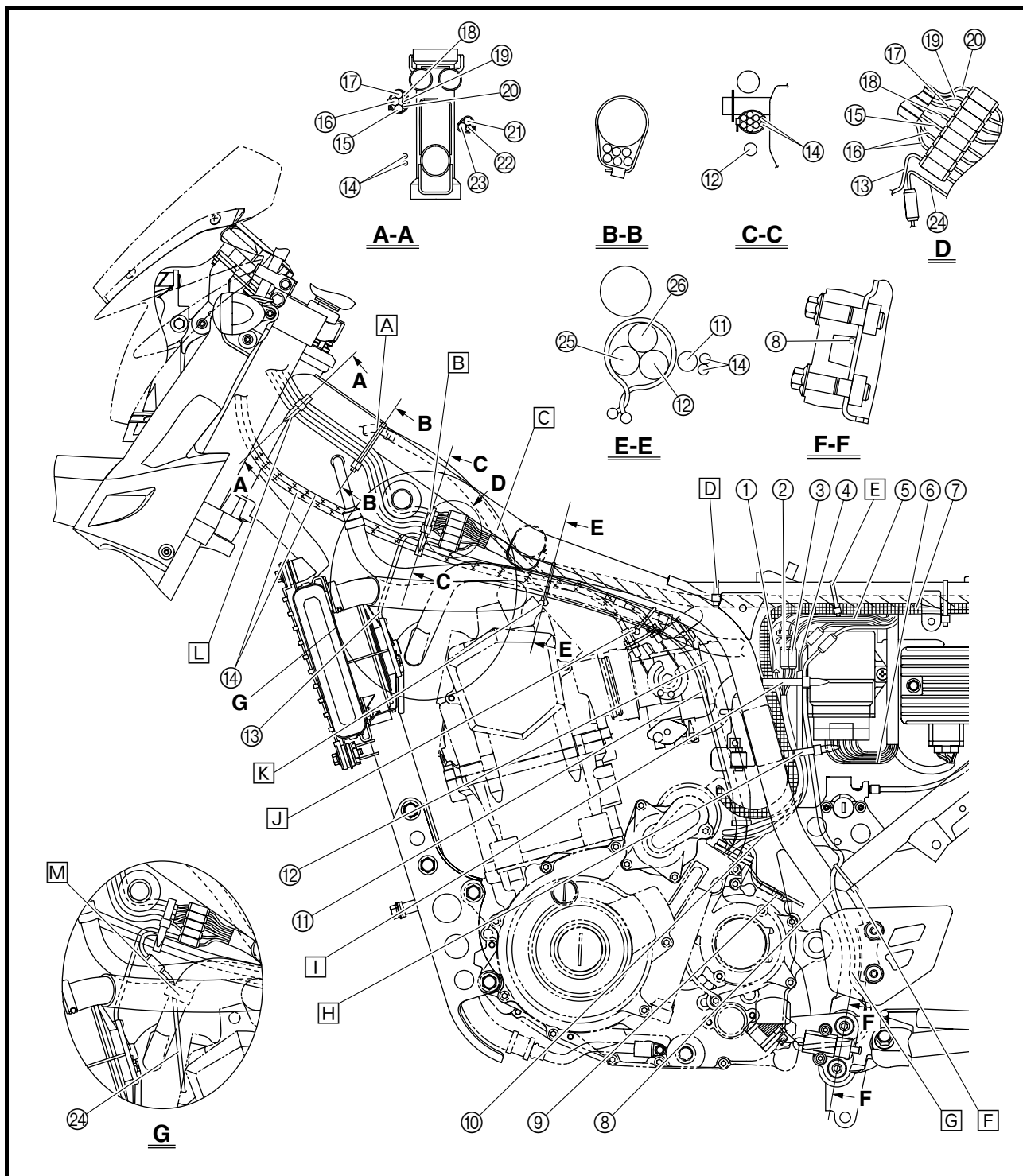

CABLE ROUTING

SPEC



- ① Immobilizer unit coupler
- ② Intake air temperature sensor
- ③ Fuel injector lead
- ④ Fuel pump lead
- ⑤ Fuel sender lead
- ⑥ Oil tank breather hose

- A** 0 ~ 10 mm (0 ~ 0.39 in)
- B** 30 ~ 40 mm (1.18 ~ 1.57 in)
- C** 5 ~ 15 mm (0.20 ~ 0.59 in)
- D** Fasten the wire harness to the frame with a plastic locking tie.
- E** To the fuel tank
- F** 0 ~ 5 mm (0 ~ 0.20 in)
- G** Europe, ZA

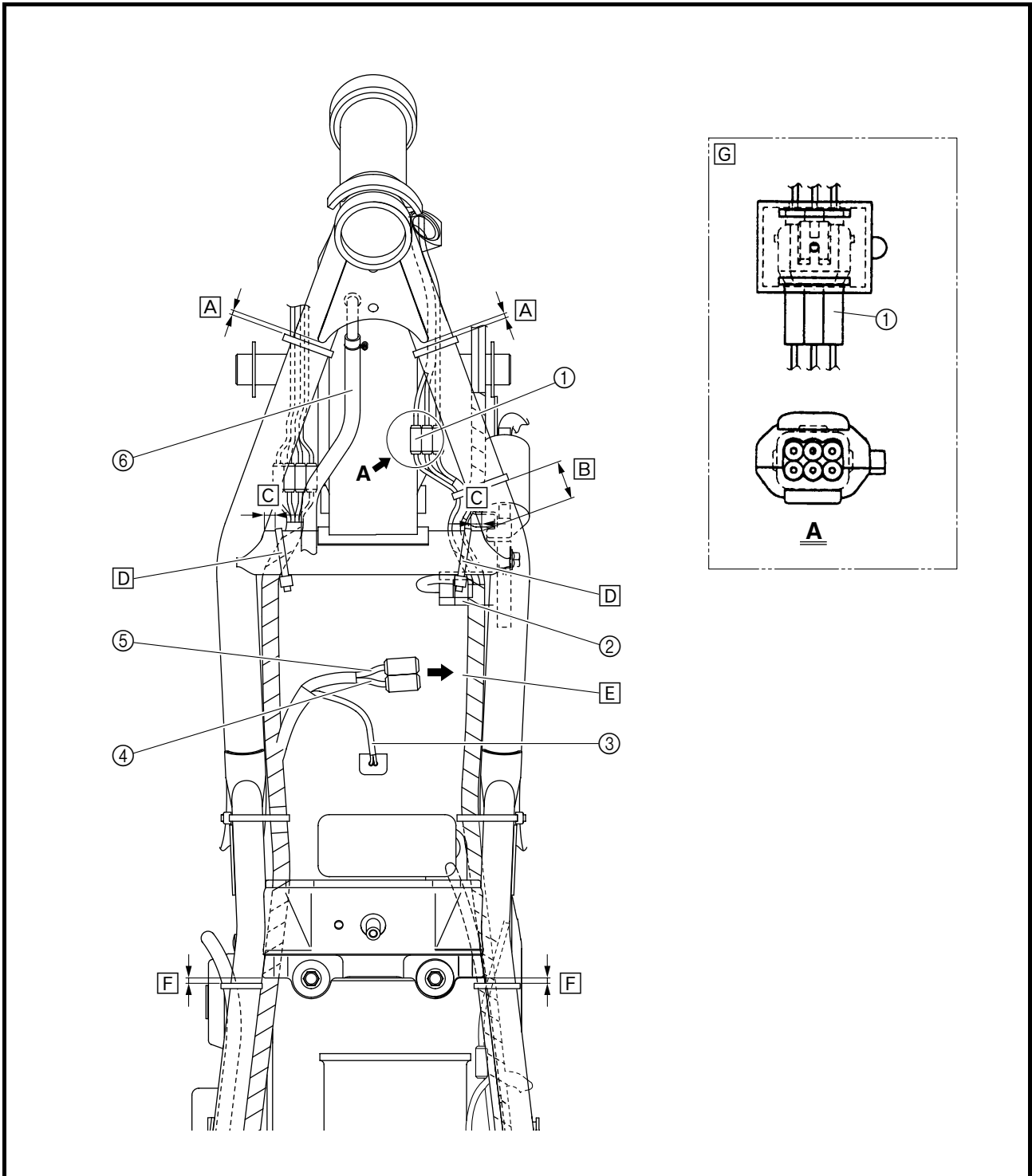

CABLE ROUTING



- ① Battery
- ② Negative battery lead
- ③ Tail/brake light coupler
- ④ Rear turn signal light connector
- ⑤ Seat lock cable
- ⑥ Anti-theft alarm coupler
- ⑦ Fuse box 2
- ⑧ Positive battery lead
- ⑨ Fuse box 1
- ⑩ Rear fender
- ⑪ Rear fender cover

- A** Fasten the tail/brake light lead with two plastic locking ties so that the coupler is positioned to the inside of where the relays (turn signal/hazard relay, headlight relay, radiator fan motor relay, and relay unit) branch off from the wire harness.
- B** To relays (turn signal/hazard relay, headlight relay, radiator fan motor relay, and relay unit)

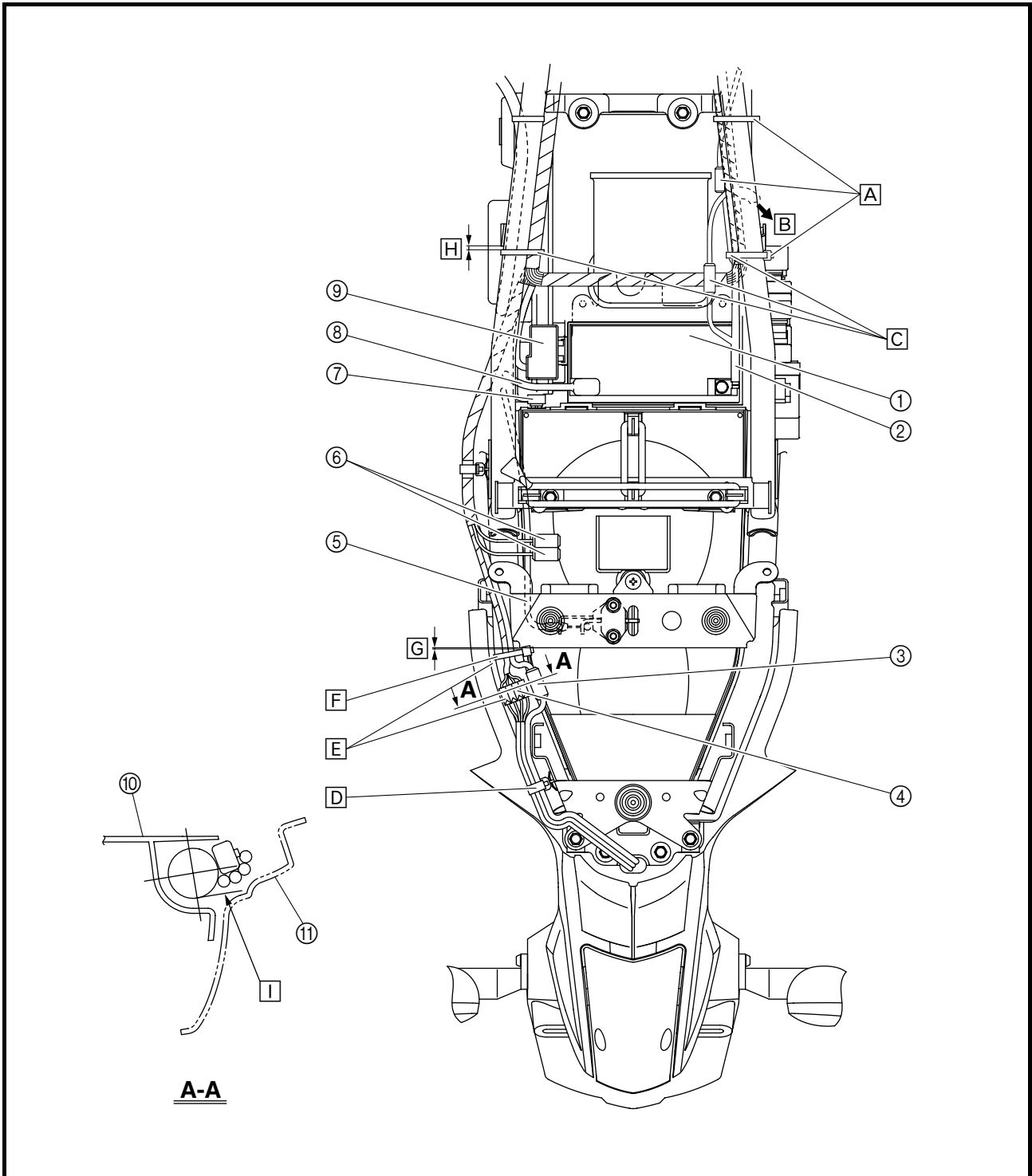

CABLE ROUTING

SPEC



- C** Fasten the wire harness with plastic locking ties, making sure to install the ties around the taped sections of the harness. Do not install the plastic locking ties around the sections of the leads that are not covered by the tape and do not fasten the negative battery lead coupler.
- D** Fasten the rear turn signal light leads and tail/brake light lead with a lead holder.
- E** Connect the couplers so that they are not pinched between the rear fender and rear fender cover.
- F** Fasten the wire harness to the frame with a plastic locking tie.
- G** 0 ~ 5 mm (0 ~ 0.20 in)
- H** 0 ~ 10 mm (0 ~ 0.39 in)
- I** The tail/brake light coupler and the rear turn signal light lead should not be lower than the line shown in the illustration.

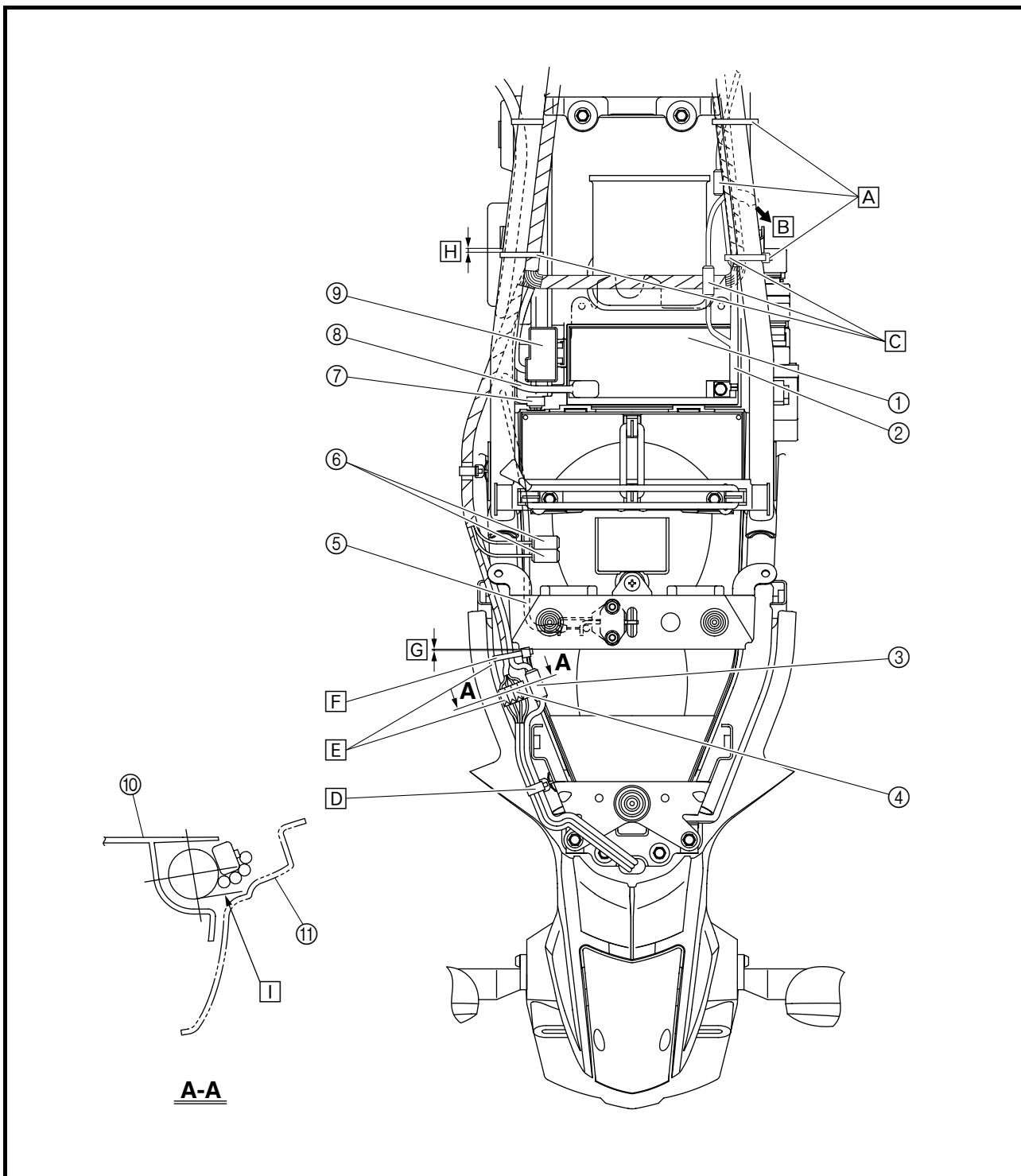

CABLE ROUTING

SPEC



XT660R

- ① Brake fluid reservoir
- ② Brake fluid reservoir hose
- ③ Rear brake light switch
- ④ Rear brake master cylinder
- ⑤ Rear brake hose
- ⑥ Rear brake caliper

- A** When installing the brake hose onto the brake master cylinder, make sure that the brake pipe touches the brake master cylinder as shown.
- B** Fasten the rear brake hose with the brake hose holder.
- C** When installing the brake hose onto the brake caliper, make sure that the brake pipe touches the brake caliper as shown.

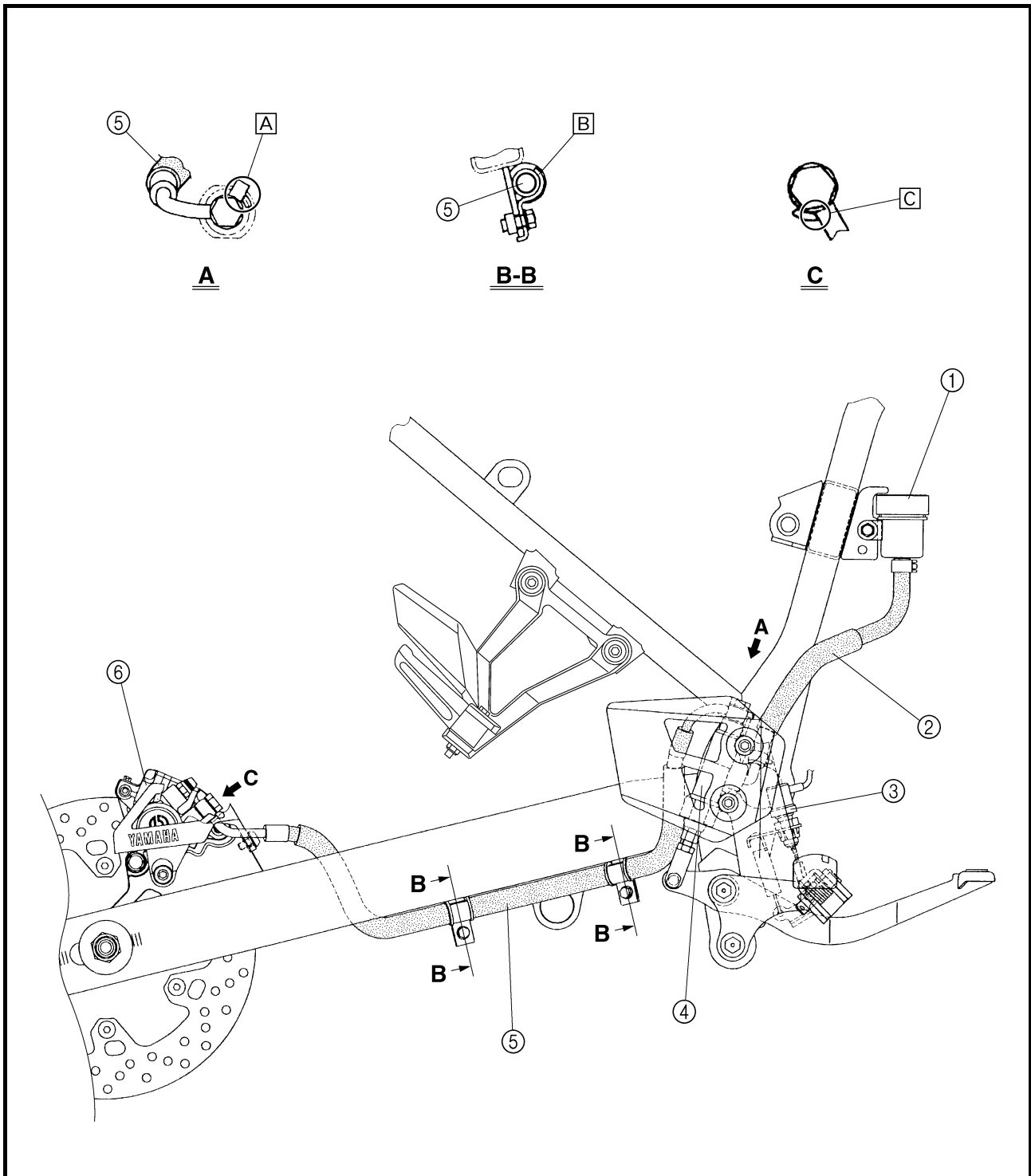

CABLE ROUTING

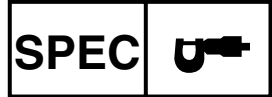

XT660X

- ① Brake fluid reservoir
- ② Brake fluid reservoir hose
- ③ Rear brake light switch
- ④ Rear brake master cylinder
- ⑤ Rear brake hose
- ⑥ Rear brake caliper

- Ⓐ When installing the brake hose onto the brake master cylinder, make sure that the brake pipe touches the brake master cylinder as shown.
- Ⓑ Fasten the rear brake hose with the brake hose holder.
- Ⓒ When installing the brake hose onto the brake caliper, make sure that the brake pipe touches the brake caliper as shown.

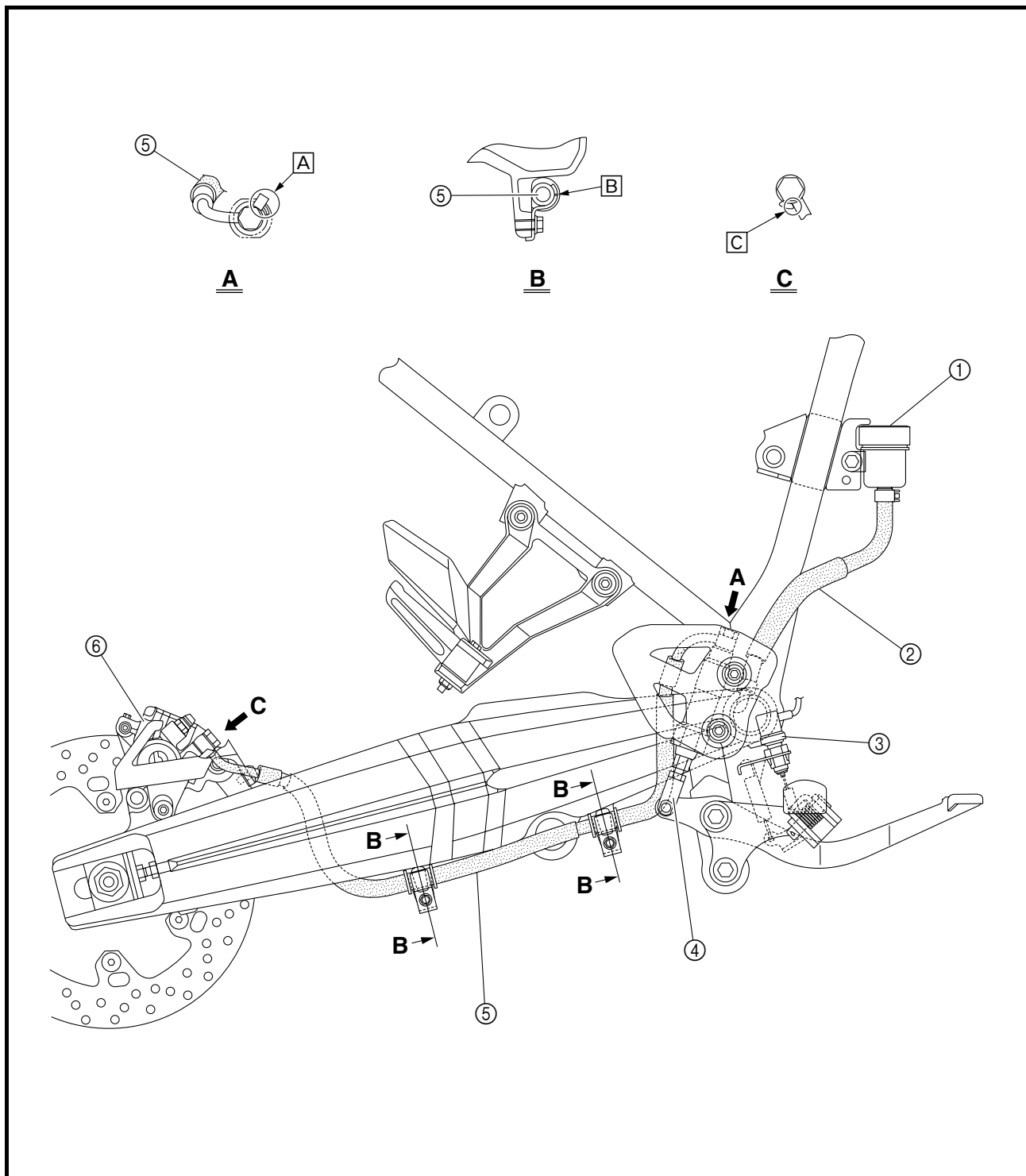

COWLING AND COVER



PERIODIC CHECKS AND ADJUSTMENTS

COWLING AND COVER

COVER

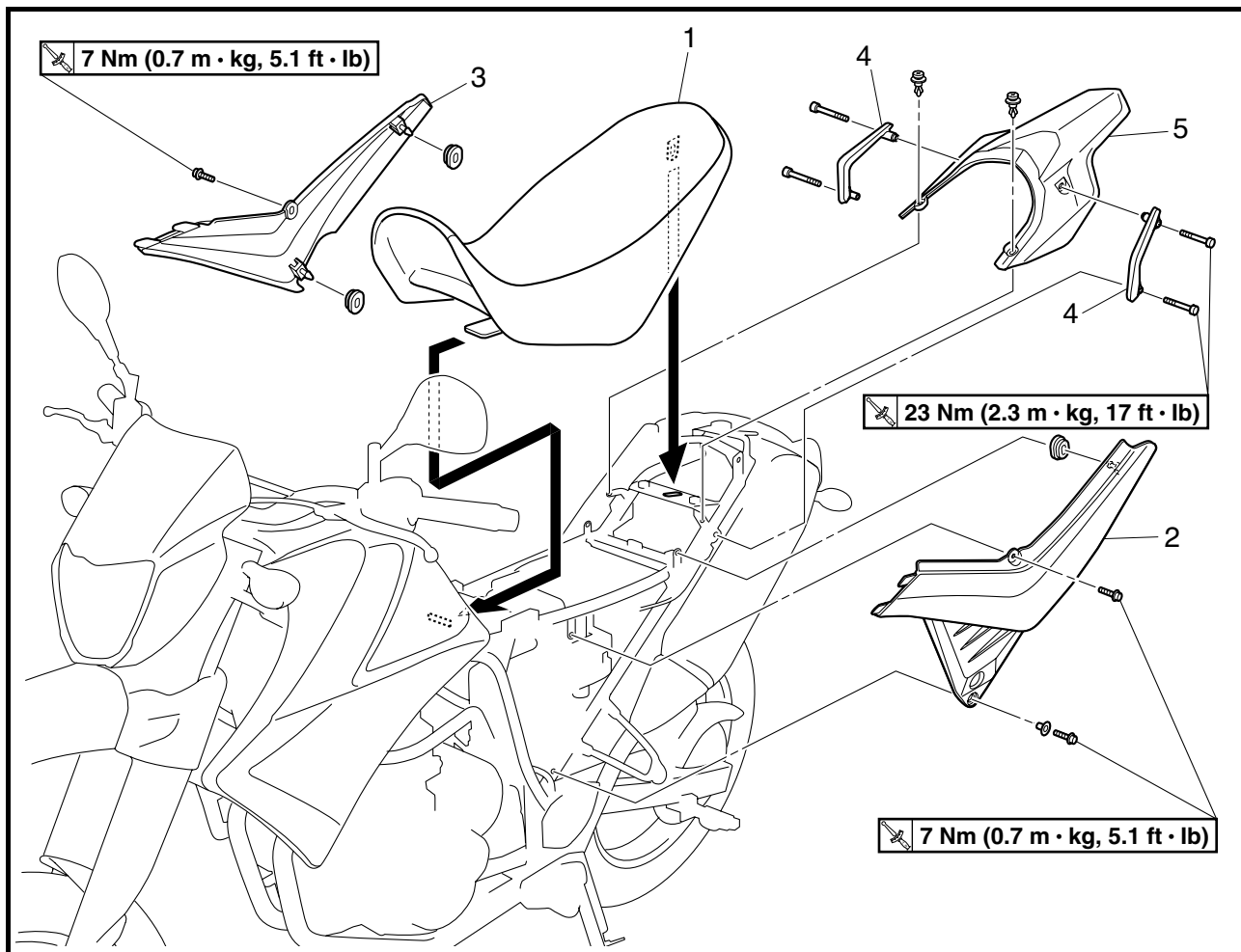

Order	Job/Part	Q'ty	Remarks
	Removing the cover (XT660X)		Remove the parts in the order listed.
1	Seat	1	
2	Left side panel	1	
3	Right side panel	1	
4	Grab bar	2	
5	Rear cover	1	
			For installation, reverse the removal procedure.

COWLING AND COVER



COWLING

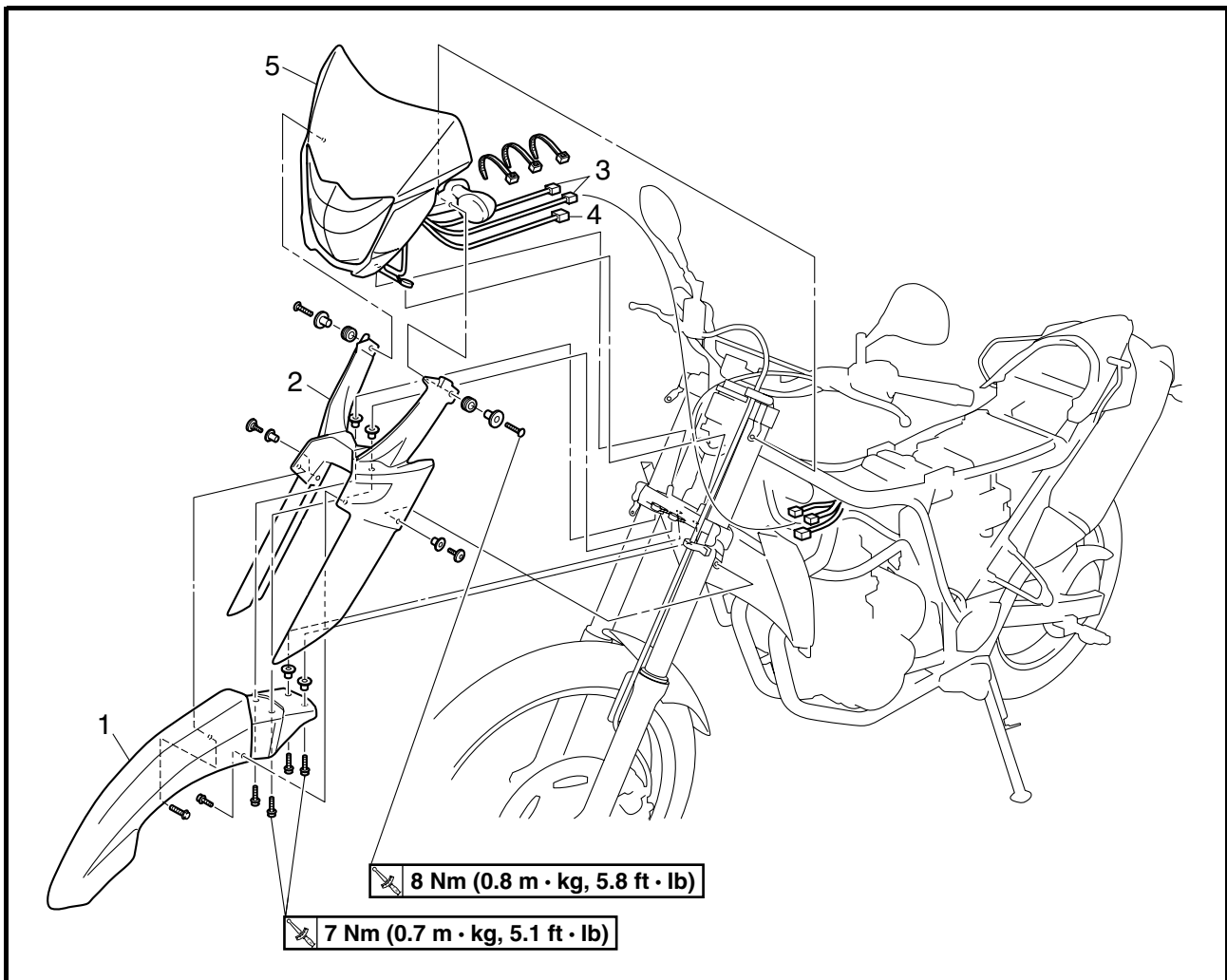

Order	Job/Part	Q'ty	Remarks
	Removing the cowling (XT660X)		Remove the parts in the order listed.
	Seat/side panels (left and right)		Refer to "COWLING AND COVER".
	Fuel tank		Refer to "FUEL TANK".
1	Front fender	1	
2	Front fork protector	1	
3	Meter assembly coupler	2	Disconnect.
4	Sub-wire harness coupler	1	Disconnect.
5	Front cowling assembly	1	
			For installation, reverse the removal procedure.



EAS00040

FUEL TANK

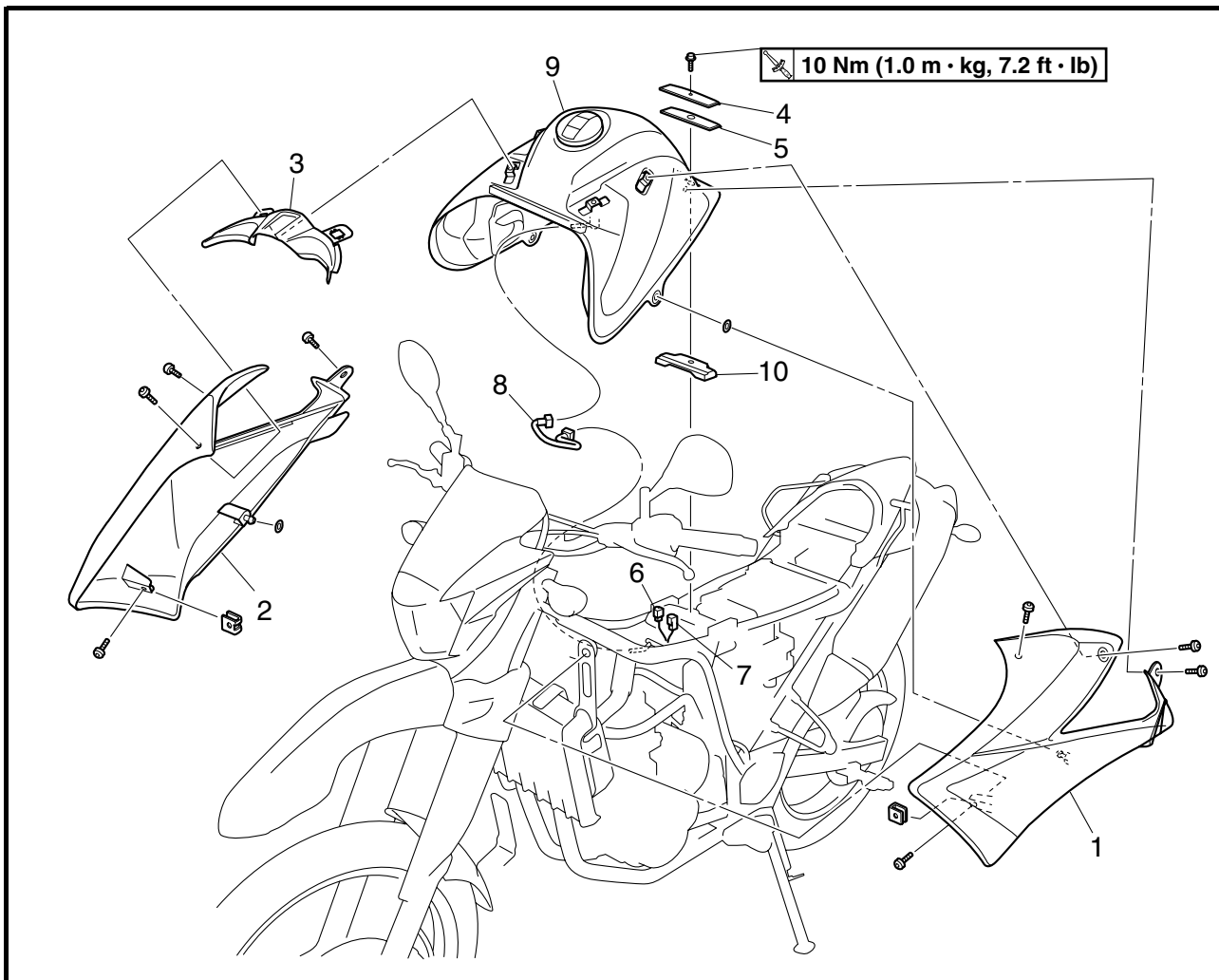

Order	Job/Part	Q'ty	Remarks
	Removing the fuel tank (XT660X)		Remove the parts in the order listed.
	Seat/side panels (left and right)		Refer to "COWLING AND COVER".
	Fuel		Drain.
1	Fuel tank left side cover	1	
2	Fuel tank right side cover	1	
3	Intake air guide	1	
4	Fuel tank plate	1	
5	Damper 1	1	
6	Fuel pump coupler	1	Disconnect.
7	Fuel sender coupler	1	Disconnect.
8	Fuel hose	1	Refer to "REMOVING THE FUEL TANK" and "INSTALLING THE FUEL HOSE" in chapter 3. (Manual No.: 5VK1-AE1)
9	Fuel tank	1	

FUEL TANK

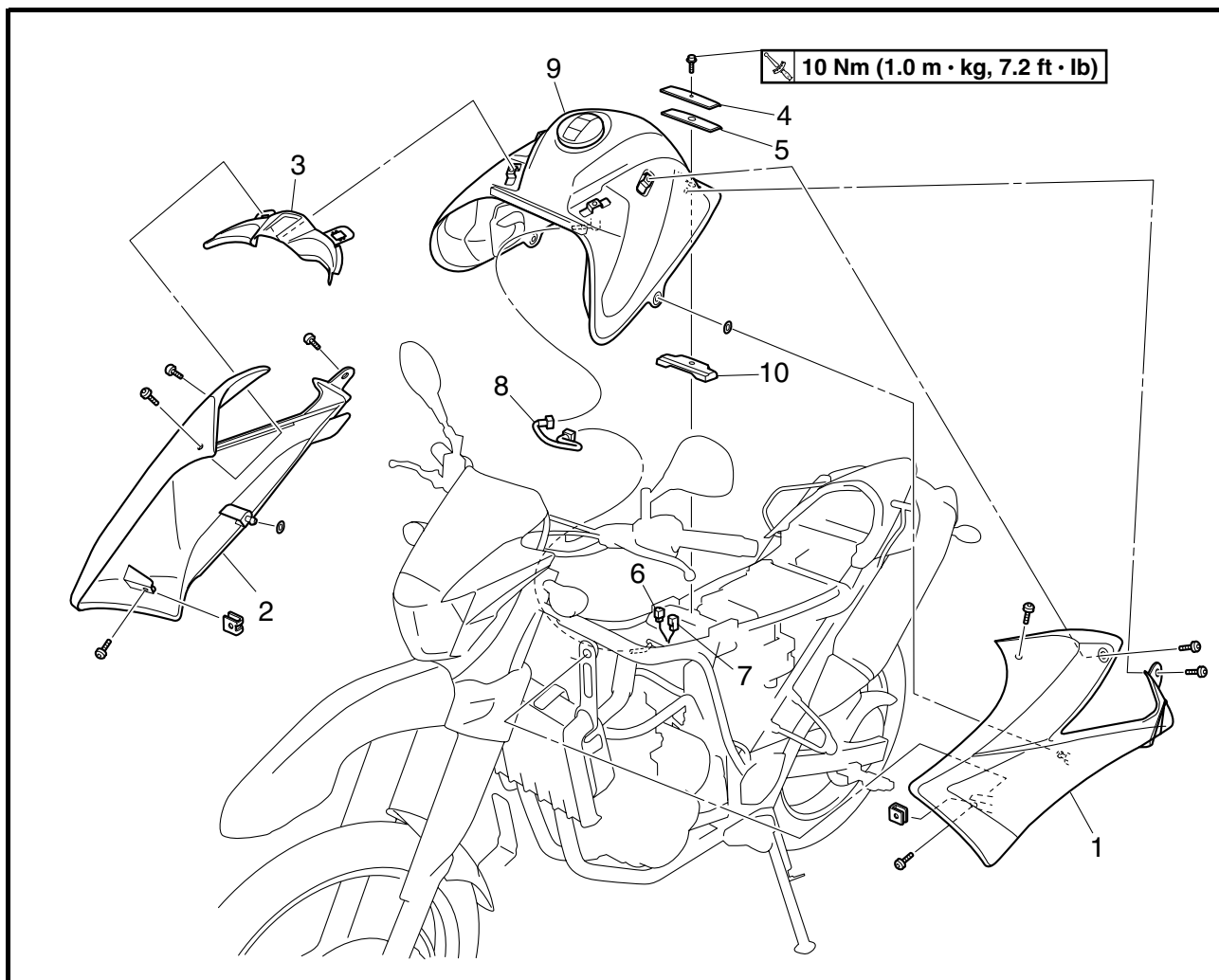

Order	Job/Part	Q'ty	Remarks
10	Damper 2	1	For installation, reverse the removal procedure.

ADJUSTING THE DRIVE CHAIN SLACK



EAS00140

CHASSIS

ADJUSTING THE DRIVE CHAIN SLACK

NOTE: _____

The drive chain slack must be checked at the tightest point on the chain.

CAUTION: _____

A drive chain that is too tight will overload the engine and other vital parts, and one that is too loose can skip and damage the swingarm or cause an accident. Therefore, keep the drive chain slack within the specified limits.

1. Stand the motorcycle on a level surface.

⚠ WARNING _____

Securely support the motorcycle so that there is no danger of it falling over.

NOTE: _____

Place the motorcycle on a suitable stand so that the rear wheel is elevated.

2. Spin the rear wheel several times and find the tightest position of the drive chain.

3. Check:

- drive chain slack ①
Out of specification → Adjust.

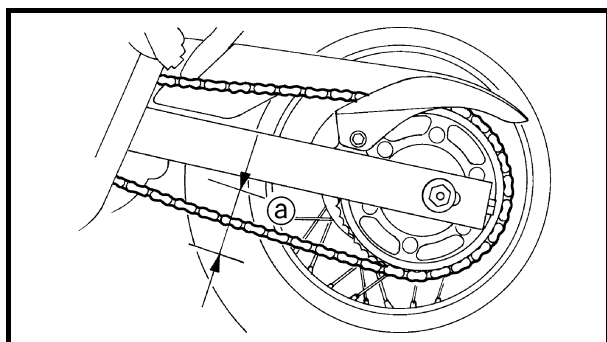

Drive chain slack
40.0 ~ 55.0 mm (1.57 ~ 2.17 in)

CHECKING THE TIRES

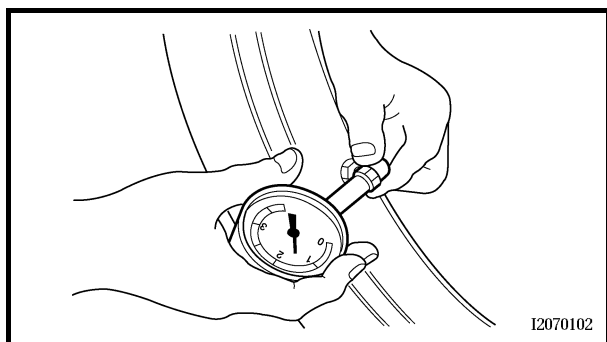

EAS00166

CHECKING THE TIRES

The following procedure applies to both of the tires.

1. Check:
 - tire pressure
 Out of specification → Regulate.

⚠ WARNING

- The tire pressure should only be checked and regulated when the tire temperature equals the ambient air temperature.
- The tire pressure and the suspension must be adjusted according to the total weight (including cargo, rider, passenger and accessories) and the anticipated riding speed.
- Operation of an overloaded motorcycle could cause tire damage, an accident or an injury.

NEVER OVERLOAD THE MOTORCYCLE.

XT660R

Basic weight (with oil and a full fuel tank)	181.0 kg (399 lb)	
Maximum load*	186.0 kg (410 lb)	
Cold tire pressure	Front	Rear
Up to 90 kg load*	200 kPa (2.00 kgf/cm², 29 psi)	200 kPa (2.00 kgf/cm², 29 psi)
90 kg ~ maxi- mum load*	200 kPa (2.00 kgf/cm², 29 psi)	225 kPa (2.25 kgf/cm², 33 psi)
Off-road riding	200 kPa (2.00 kgf/cm², 29 psi)	200 kPa (2.00 kgf/cm², 29 psi)

CHECKING THE TIRES



XT660X

Basic weight (with oil and a full fuel tank)	186.0 kg (410 lb)	
Maximum load*	186.0 kg (410 lb)	
Cold tire pressure	Front	Rear
Up to 90 kg load*	210 kPa (2.10 kgf/cm ² , 30 psi)	210 kPa (2.10 kgf/cm ² , 30 psi)
90 kg ~ maxi- mum load*	220 kPa (2.20 kgf/cm ² , 31 psi)	230 kPa (2.30 kgf/cm ² , 33 psi)

* Total weight of rider, passenger, cargo and accessories

⚠ WARNING

It is dangerous to ride with a worn-out tire. When the tire tread reaches the wear limit, replace the tire immediately.

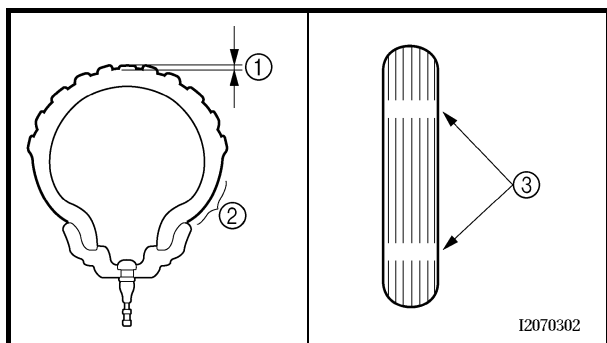

2. Check:

- tire surfaces
- Damage/wear → Replace the tire.

	Minimum tire tread depth 1.6 mm (0.063 in)
--	---

- ① Tire tread depth
- ② Sidewall
- ③ Wear indicator

⚠ WARNING

- Do not use a tubeless tire on a wheel designed only for tube tires to avoid tire failure and personal injury from sudden deflation.
- When using tube tires, be sure to install the correct tube.
- Always replace a new tube tire and a new tube as a set.
- To avoid pinching the tube, make sure the wheel rim band and tube are centered in the wheel groove.

CHECKING THE TIRES

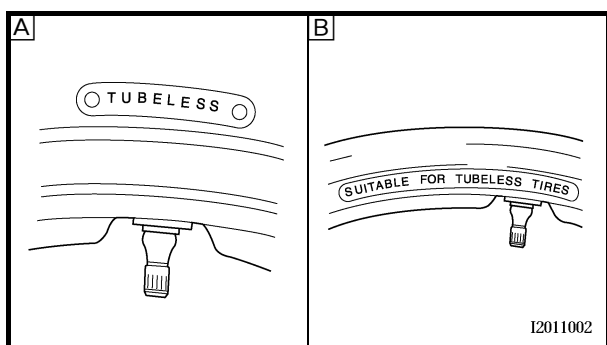

- Patching a punctured tube is not recommended. If it is absolutely necessary to do so, use great care and replace the tube as soon as possible with a good quality replacement.

- A) Tire
- B) Wheel

Tube wheel	Tube tire only
Tubeless wheel	Tube or tubeless tire

- After extensive tests, the tires listed below have been approved by Yamaha Motor Co., Ltd. for this model. The front and rear tires should always be by the same manufacturer and of the same design. No guarantee concerning handling characteristics can be given if a tire combination other than one approved by Yamaha is used on this motorcycle.

Front tire (XT660R)

Manufacturer	Model	Size
METZELER	TOURANCE FRONT	90/90-21M/C 54S
MICHELIN	SIRAC	90/90-21M/C 54T

Rear tire (XT660R)

Manufacturer	Model	Size
METZELER	TOURANCE	130/80-17M/C 65S
MICHELIN	SIRAC A	130/80-17M/C 65T

Front tire (XT660X)

Manufacturer	Model	Size
PIRELLI	DRAGON	120/70R 17M/C 58H
METZELER	SPORTEC M1	120/70ZR 17M/C 58W
MICHELIN	RADIAL PILOT SPORT	120/70ZR 17M/C 58W

CHECKING THE TIRES



Rear tire (XT660X)

Manufacturer	Model	Size
PIRELLI	DRAGON	160/60R 17M/C 69H
METZELER	SPORTEC M1	160/60ZR 17M/C 69W
MICHELIN	RADIAL PILOT SPORT	160/60ZR 17M/C 69W

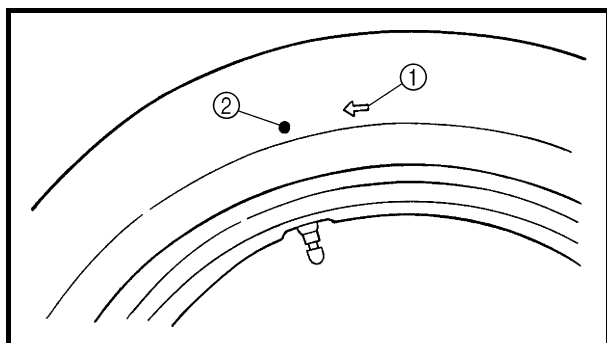
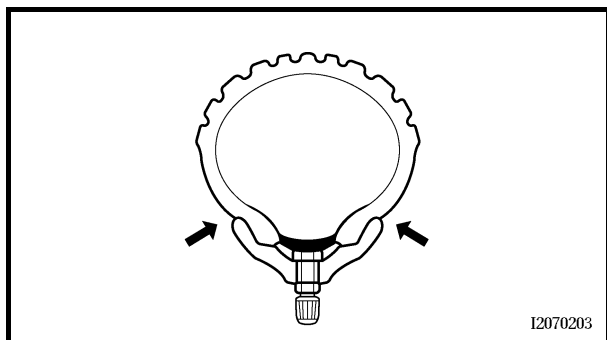

⚠ WARNING

New tires have a relatively low grip on the road surface until they have been slightly worn. Therefore, approximately 100 km should be traveled at normal speed before any high-speed riding is done.

NOTE:

- For tires with a direction of rotation mark ①:
- Install the tire with the mark pointing in the direction of wheel rotation.
 - Align the mark ② with the valve installation point.

REAR WHEEL, BRAKE DISC, AND REAR WHEEL SPROCKET



CHASSIS

REAR WHEEL, BRAKE DISC, AND REAR WHEEL SPROCKET

REAR WHEEL

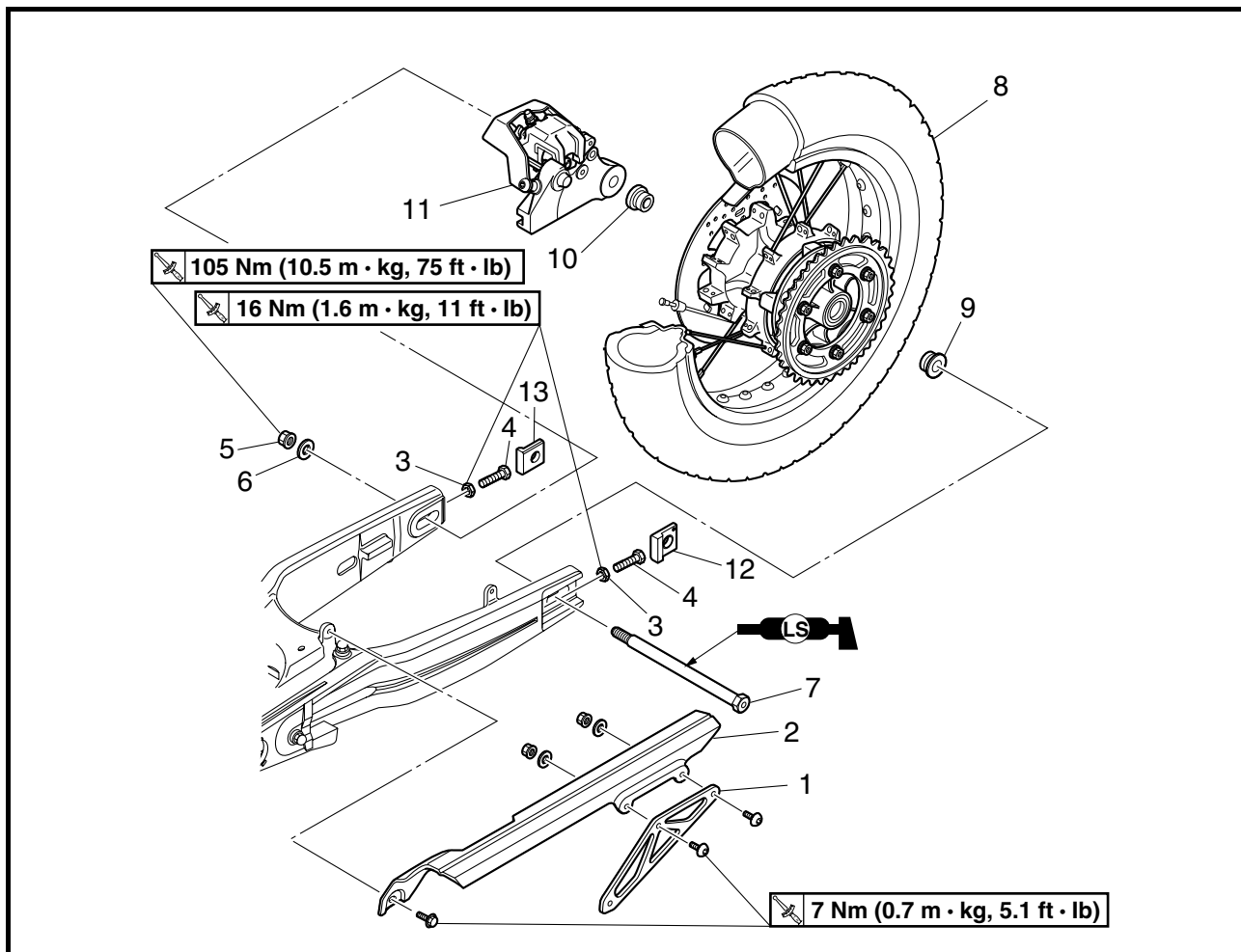

Order	Job/Part	Q'ty	Remarks
	Removing the rear wheel (XT660X)		Remove the parts in the order listed.
1	Stabilizer	1	Refer to "REMOVING THE REAR WHEEL (XT660X)" and "INSTALLING THE REAR WHEEL (XT660X)".
2	Chain cover	1	
3	Locknut	2	
4	Adjusting bolt	2	
5	Wheel axle nut	1	
6	Washer	1	
7	Wheel axle	1	
8	Rear wheel	1	
9	Collar (left)	1	
10	Collar (right)	1	
11	Rear brake caliper	1	

REAR WHEEL, BRAKE DISC, AND REAR WHEEL SPROCKET

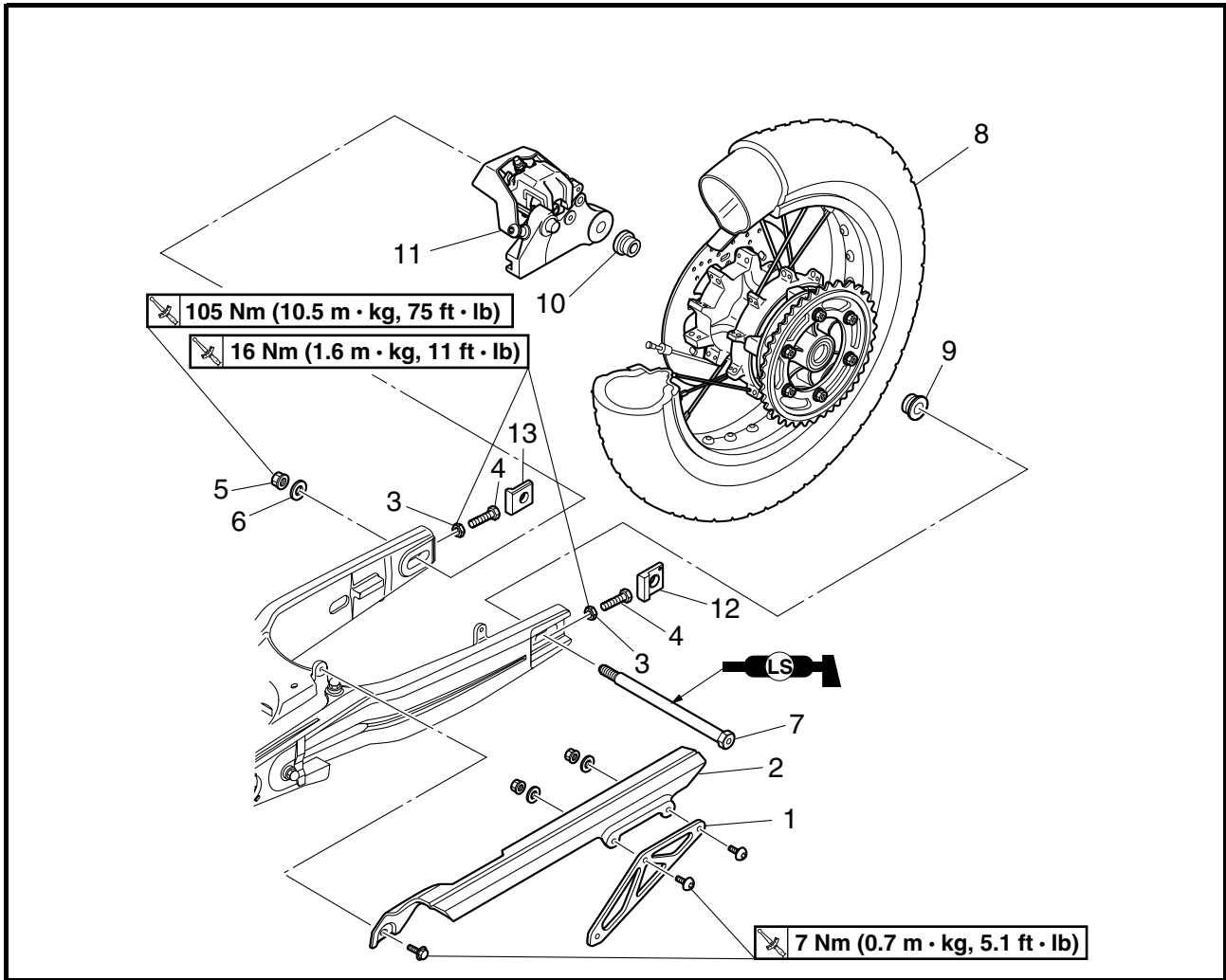

Order	Job/Part	Q'ty	Remarks
12	Chain puller (left)	1	Refer to "INSTALLING THE REAR WHEEL (XT660X)". For installation, reverse the removal procedure.
13	Chain puller (right)	1	

REAR WHEEL, BRAKE DISC, AND REAR WHEEL SPROCKET

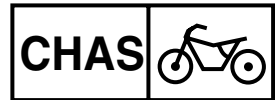

EAS00561

REMOVING THE REAR WHEEL (XT660R)

1. Stand the motorcycle on a level surface.

⚠ WARNING

Securely support the motorcycle so that there is no danger of it falling over.

NOTE:

Place the motorcycle on a suitable stand so that the rear wheel is elevated.

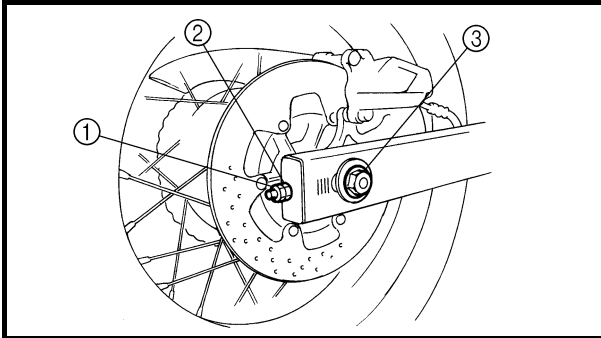

2. Loosen:

- locknut ①
- adjusting nut ②

3. Remove:

- chain cover
- wheel axle nut ③
- washer (N)
- wheel axle
- washer (O)
- rear wheel

NOTE:

Push the rear wheel forward and remove the drive chain from the rear wheel sprocket.

4. Remove:

- brake caliper

NOTE:

Do not depress the brake pedal when removing the brake caliper.

REAR WHEEL, BRAKE DISC, AND REAR WHEEL SPROCKET

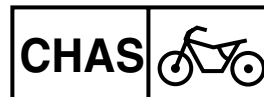

EAS00561

REMOVING THE REAR WHEEL (XT660X)

1. Stand the motorcycle on a level surface.

⚠ WARNING

Securely support the motorcycle so that there is no danger of it falling over.

NOTE:

Place the motorcycle on a suitable stand so that the rear wheel is elevated.

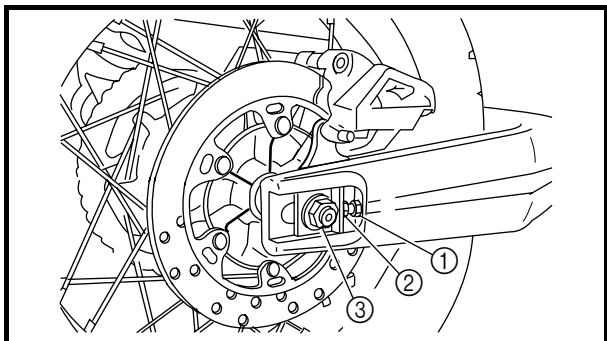

2. Loosen:

- locknut ①
- adjusting nut ②

3. Remove:

- stabilizer
- chain cover
- wheel axle nut ③
- washer
- wheel axle
- rear wheel

NOTE:

Push the rear wheel forward and remove the drive chain from the rear wheel sprocket.

4. Remove:

- brake caliper

NOTE:

Do not depress the brake pedal when removing the brake caliper.

EAS00571

INSTALLING THE REAR WHEEL (XT660R)

1. Lubricate:

- wheel axle
- oil seal lips



Recommended lubricant
Lithium-soap-based grease

REAR WHEEL, BRAKE DISC, AND REAR WHEEL SPROCKET

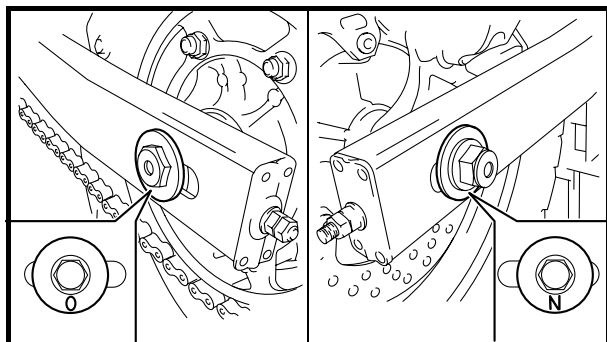

2. Install:
 - rear wheel
 - washer (O)
 - wheel axle
 - washer (N)
 - wheel axle nut

NOTE:

Install the washer with the “N” mark on the right-hand side of the vehicle and the washer with the “O” mark on the left-hand side of the vehicle. Be sure to install both washers with the marks facing outward.

3. Adjust:
 - drive chain slack



Drive chain slack
40.0 ~ 55.0 mm (1.57 ~ 2.17 in)

Refer to “ADJUSTING THE DRIVE CHAIN SLACK”.

4. Tighten:
 - wheel axle nut

 105 Nm (10.5 m · kg, 75 ft · lb)

5. Install:
 - chain cover
 - chain cover bolts

 7 Nm (0.7 m · kg, 5.1 ft · lb)

EAS00571

INSTALLING THE REAR WHEEL (XT660X)

1. Lubricate:
 - wheel axle
 - oil seal lips

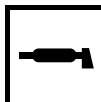

Recommended lubricant
Lithium-soap-based grease

REAR WHEEL, BRAKE DISC, AND REAR WHEEL SPROCKET

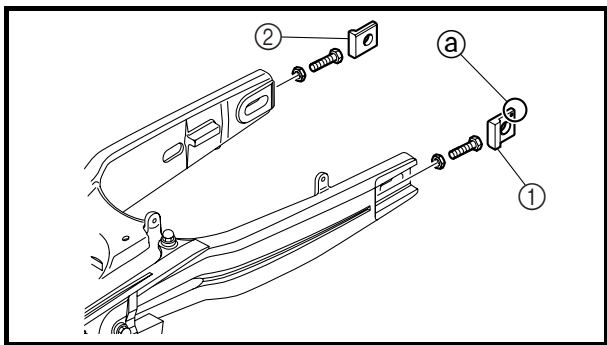

2. Install:
- chain puller (left) ①
 - chain puller (right) ②
 - rear wheel
 - washer
 - wheel axle
 - wheel axle nut

NOTE: _____
Install the chain puller with the mark ① on the left side of the swingarm.

3. Adjust:
- drive chain slack



Drive chain slack
40.0 ~ 55.0 mm (1.57 ~ 2.17 in)

Refer to “ADJUSTING THE DRIVE CHAIN SLACK”.

4. Tighten:
- wheel axle nut

105 Nm (10.5 m · kg, 75 ft · lb)

5. Install:
- chain cover
 - chain cover bolts

7 Nm (0.7 m · kg, 5.1 ft · lb)

- stabilizer

7 Nm (0.7 m · kg, 5.1 ft · lb)

REAR WHEEL, BRAKE DISC, AND REAR WHEEL SPROCKET



EAS00700

SWINGARM AND DRIVE CHAIN

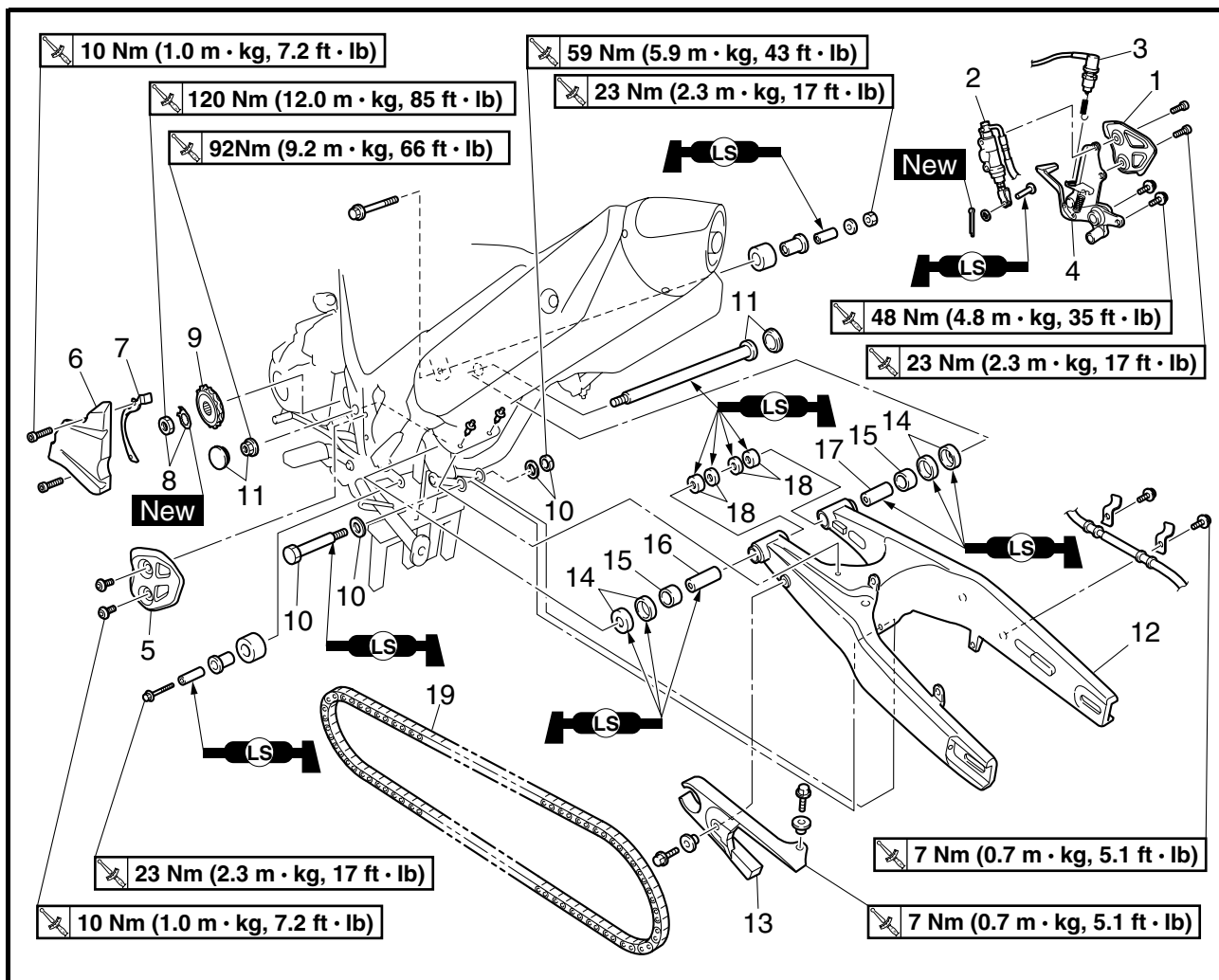

Order	Job/Part	Q'ty	Remarks
	Removing the swingarm and drive chain (XT660X)		Remove the parts in the order listed.
	Rear wheel		Refer to "REAR WHEEL, BRAKE DISC, AND REAR WHEEL SPROCKET".
1	Right side heel plate	1	
2	Brake master cylinder	1	
3	Rear brake light switch	1	
4	Right footrest/brake pedal assembly	1	
5	Left side heel plate	1	
6	Drive sprocket cover	1	Refer to "REMOVING THE DRIVE SPROCKET" and "INSTALLING THE SWINGARM" in chapter 4. (Manual No.: 5VK1-AE1)
7	Drive chain guard	1	
8	Nut/lock washer	1/1	
9	Drive sprocket	1	

REAR WHEEL, BRAKE DISC, AND REAR WHEEL SPROCKET

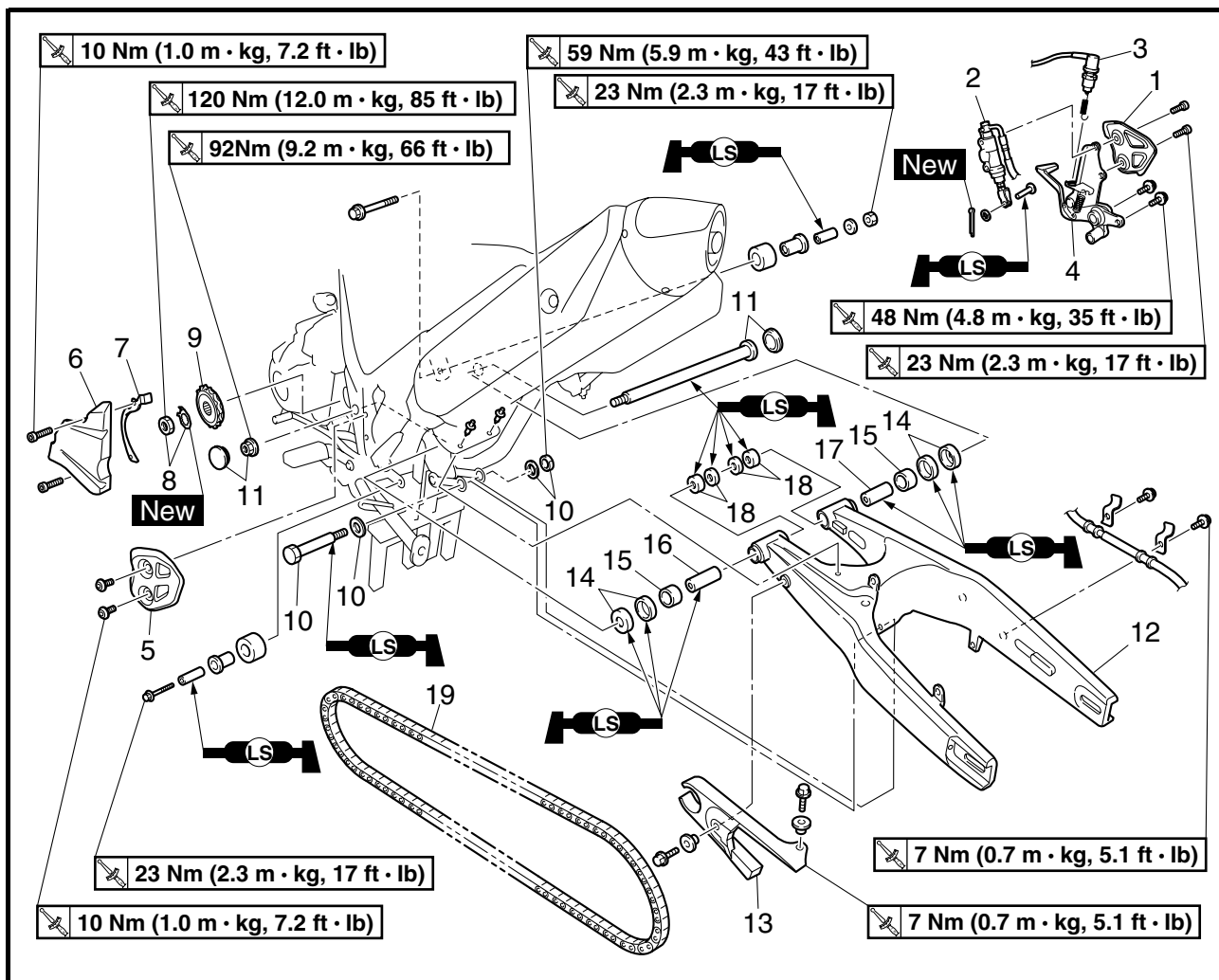

Order	Job/Part	Q'ty	Remarks
10	Nut/washer/bolt	1/2/1	Refer to "REMOVING THE DRIVE SPROCKET" and "INSTALLING THE SWINGARM" in chapter 4. (Manual No.: 5VK1-AE1)
11	Cap/pivot shaft nut/pivot shaft	2/1/1	
12	Swingarm	1	Refer to "REMOVING THE SWINGARM" and "INSTALLING THE SWINGARM" in chapter 4. (Manual No.: 5VK1-AE1)
13	Drive chain guide	1	Refer to "INSTALLING THE SWING-ARM" in chapter 4. (Manual No.: 5VK1-AE1)
14	Dust cover/oil seal	2/2	
15	Bearing	2	
16	Spacer	1	
17	Spacer	1	
18	Oil seal/bushing	2/2	
19	Drive chain	1	

REAR WHEEL, BRAKE DISC, AND REAR WHEEL SPROCKET

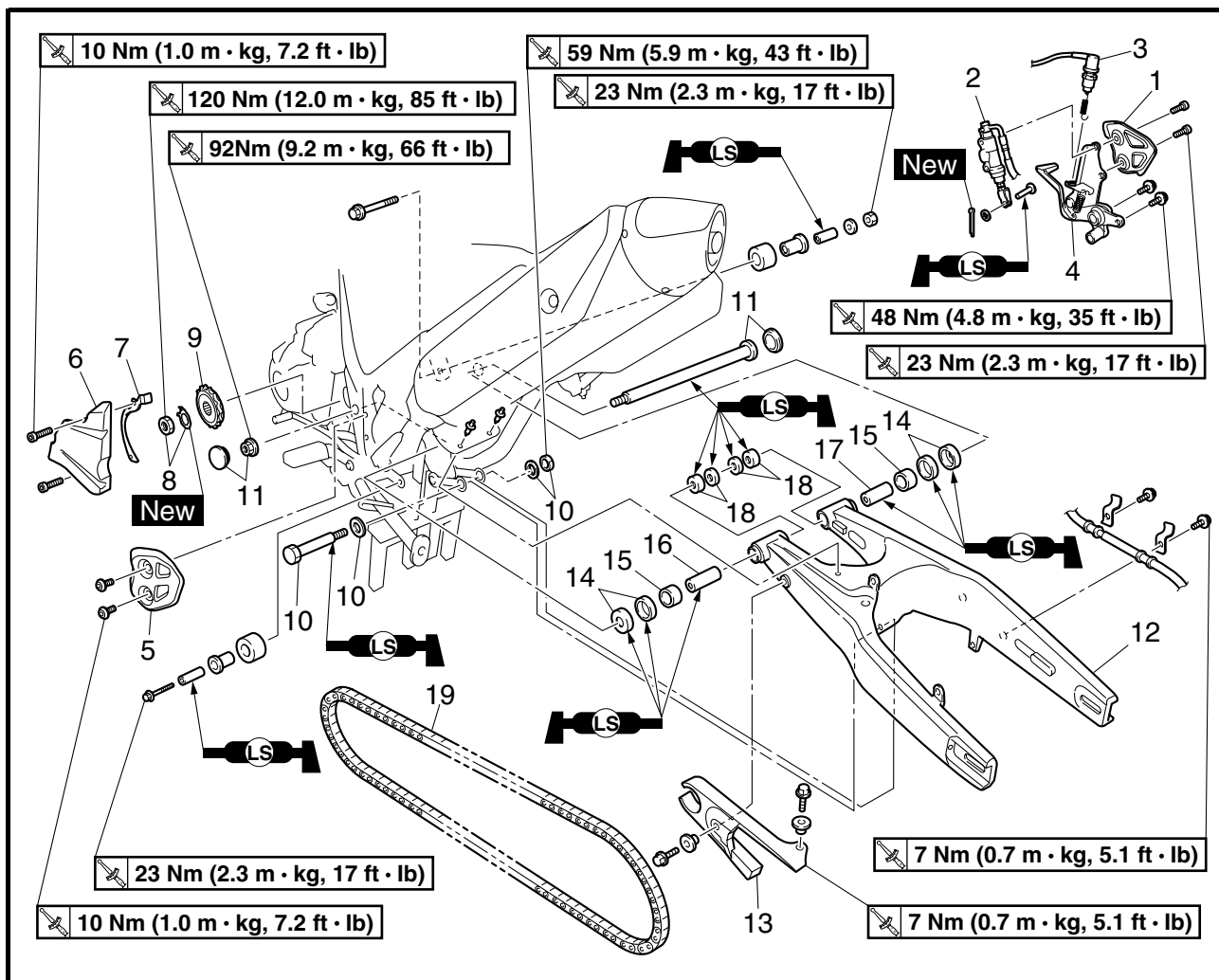

Order	Job/Part	Q'ty	Remarks
19	Drive chain	1	Refer to "REMOVING THE DRIVE CHAIN" in chapter 4. (Manual No.: 5VK1-AE1) For installation, reverse the removal procedure.

ENGINE REMOVAL



EAS00188

ENGINE

**ENGINE REMOVAL
EXHAUST PIPES AND MUFFLERS**

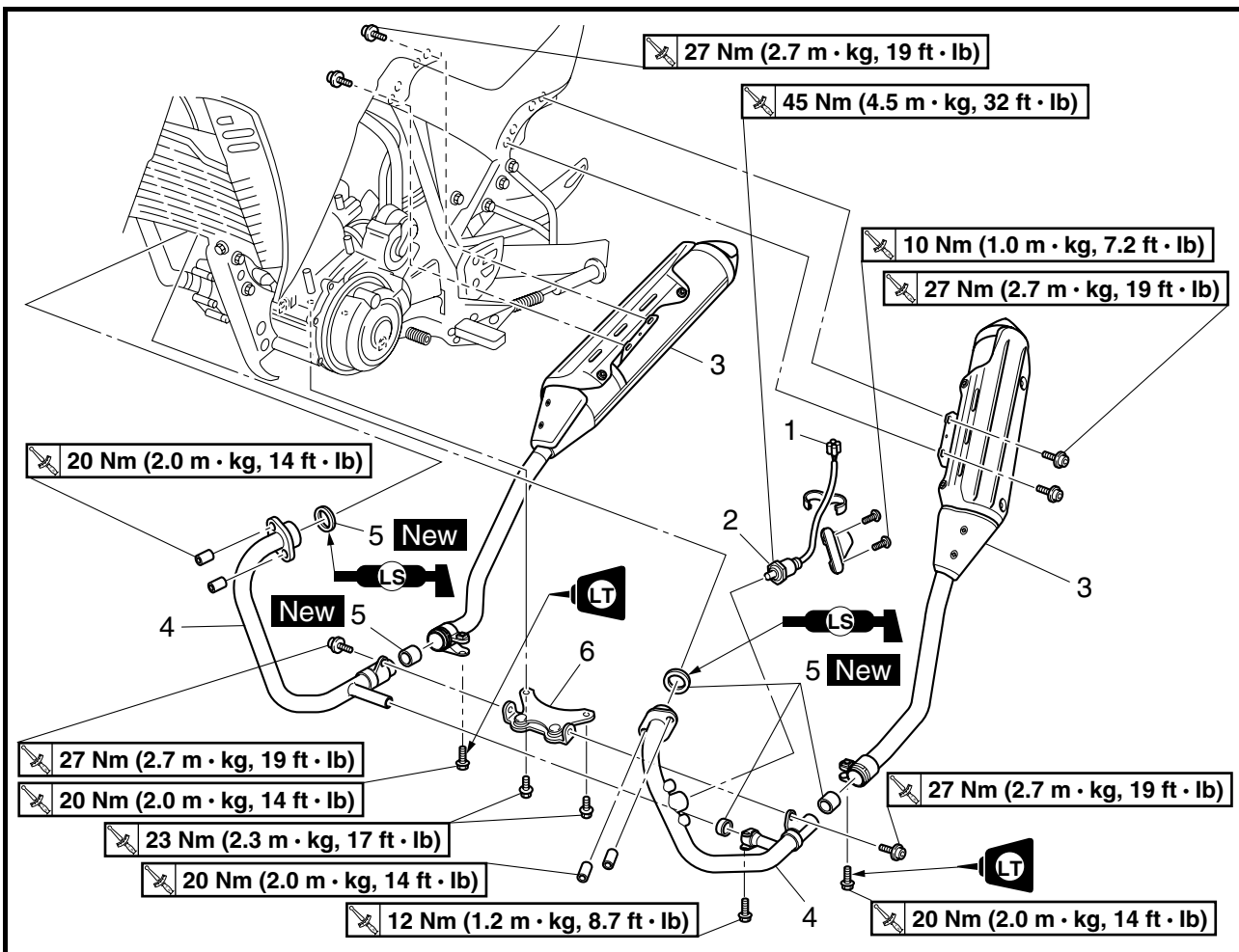

Order	Job/Part	Q'ty	Remarks
	Removing the exhaust pipes and mufflers		Remove the parts in the order listed.
1	O ₂ sensor coupler	1	Disconnect.
2	O ₂ sensor	1	
3	Muffler (left and right)	2	
4	Exhaust pipe (left and right)	2	
5	Gasket	5	
6	Exhaust pipe bracket	1	
			For installation, reverse the removal procedure.

CYLINDER HEAD



EAS00221

CYLINDER HEAD

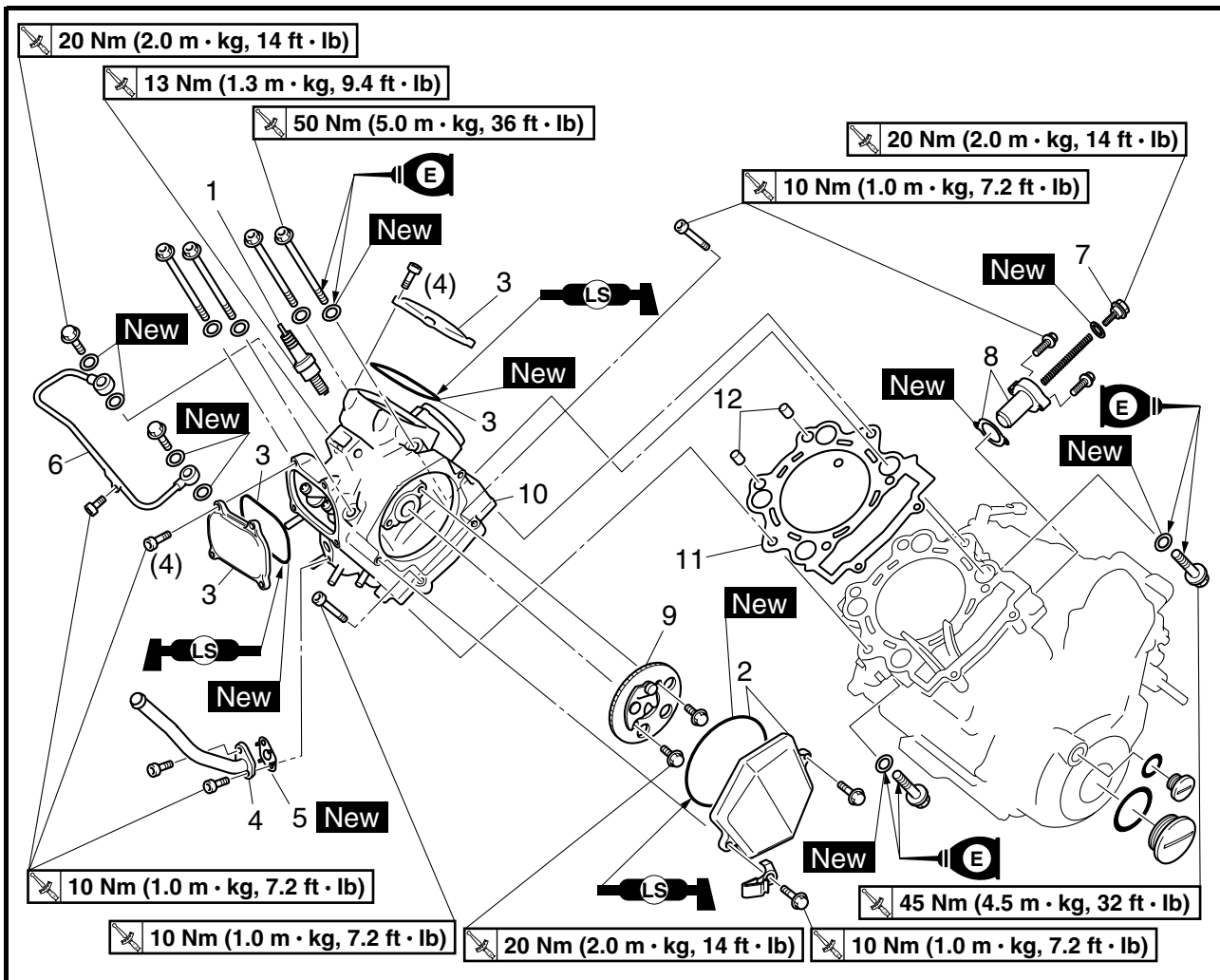

Order	Job/Part	Q'ty	Remarks
	Removing the cylinder head		
	Engine		Remove the parts in the order listed. Refer to "ENGINE REMOVAL" in chapter 5. (Manual No.: 5VK1-AE1)
	Timing mark accessing screw/crankshaft end accessing screw		Refer to "ADJUSTING THE VALVE CLEARANCE" in chapter 3. (Manual No.: 5VK1-AE1)
1	Spark plug	1	
2	Camshaft sprocket cover/O-ring	1/1	
3	Tappet cover/O-ring	2/2	
4	Air cut-off valve outlet pipe	1	
5	Gasket	1	
6	Oil delivery pipe 1	1	

CYLINDER HEAD

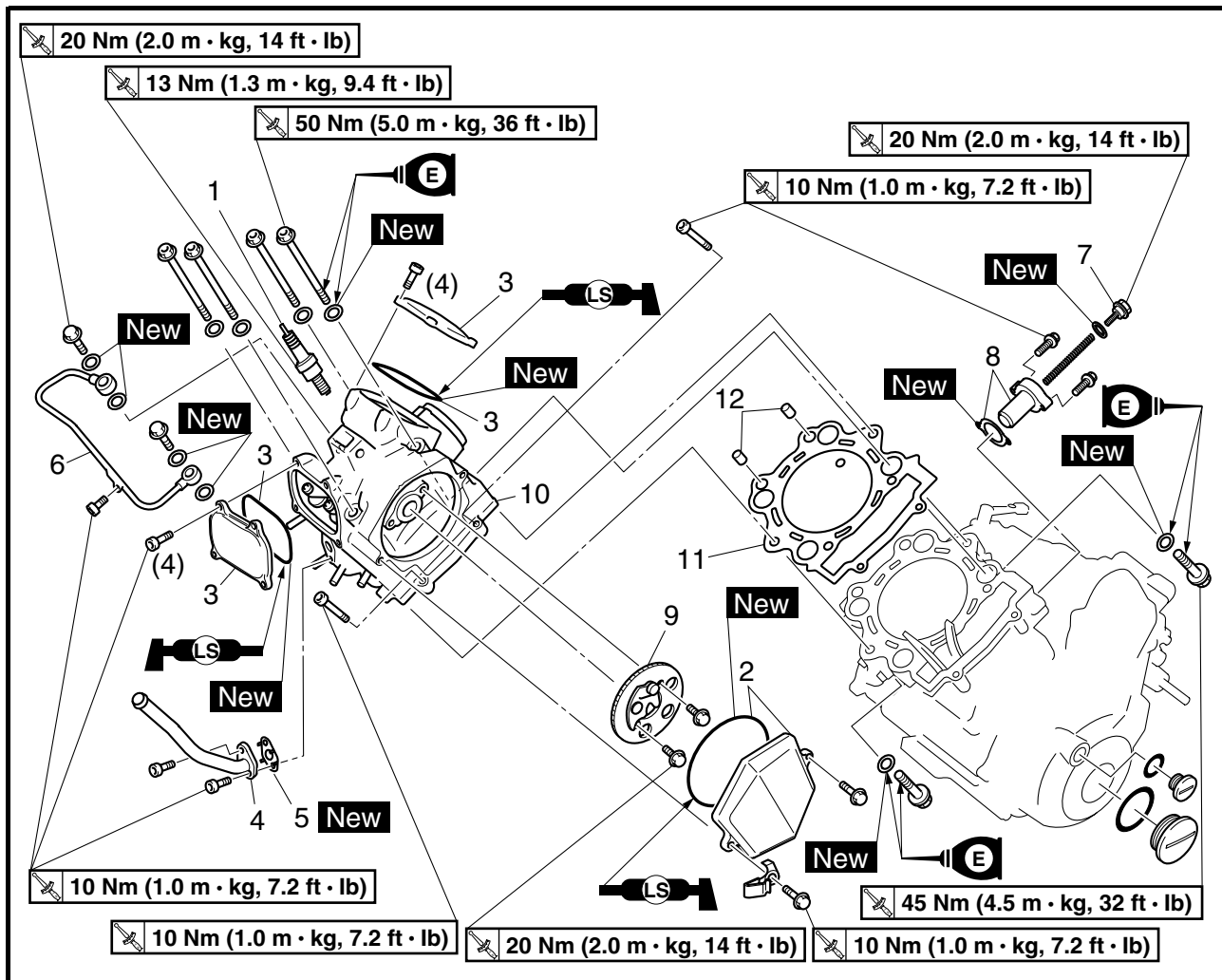

Order	Job/Part	Q'ty	Remarks
7	Timing chain tensioner cap bolt	1	Refer to "REMOVING THE CYLINDER HEAD" and "INSTALLING THE CYLINDER HEAD" in chapter 5. (Manual No.: 5VK1-AE1)
8	Timing chain tensioner/gasket	1/1	
9	Camshaft sprocket	1	
10	Cylinder head	1	
11	Cylinder head gasket	1	
12	Dowel pin	2	
			For installation, reverse the removal procedure.

CYLINDER AND PISTON



EAS00251

CYLINDER AND PISTON

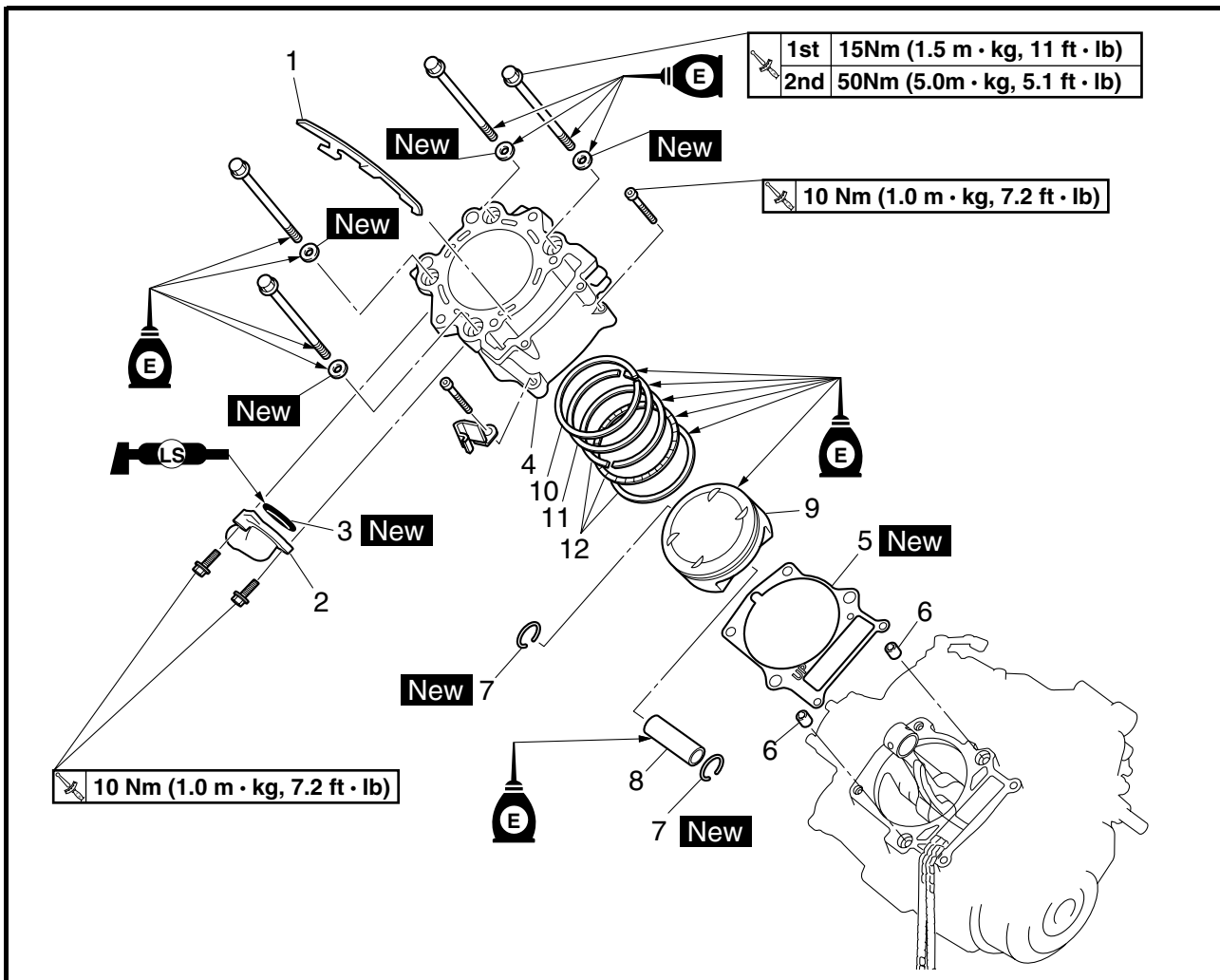

Order	Job/Part	Q'ty	Remarks
	Removing the cylinder and piston		Remove the parts in the order listed.
	Cylinder head		Refer to "CYLINDER HEAD".
1	Timing chain guide (exhaust)	1	
2	Water jacket joint	1	
3	O-ring	1	
4	Cylinder	1	Refer to "INSTALLING THE PISTON AND CYLINDER".
5	Cylinder gasket	1	
6	Dowel pin	2	(Manual No.: 5VK1-AE1)
7	Piston pin clip	2	Refer to "REMOVING THE CYLINDER AND PISTON" and "INSTALLING THE PISTON AND CYLINDER".
8	Piston pin	1	
9	Piston	1	
10	Top ring	1	(Manual No.: 5VK1-AE1)

CYLINDER AND PISTON

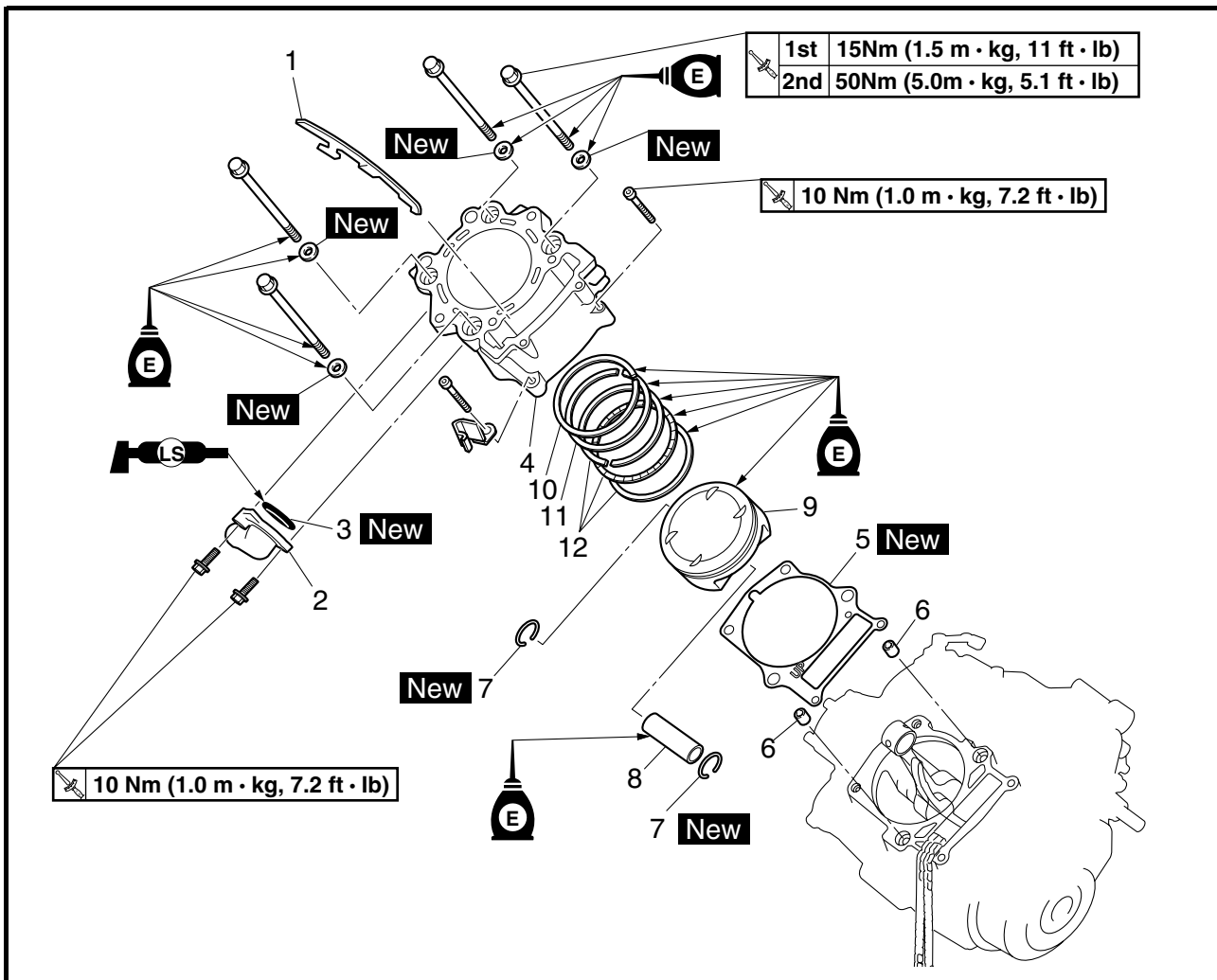

Order	Job/Part	Q'ty	Remarks
11	2nd ring	1	Refer to "REMOVING THE CYLINDER AND PISTON" and "INSTALLING THE PISTON AND CYLINDER". (Manual No.: 5VK1-AE1) For installation, reverse the removal procedure.
12	Oil ring	1	

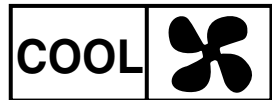

EAS00454

COOLING SYSTEM

RADIATOR

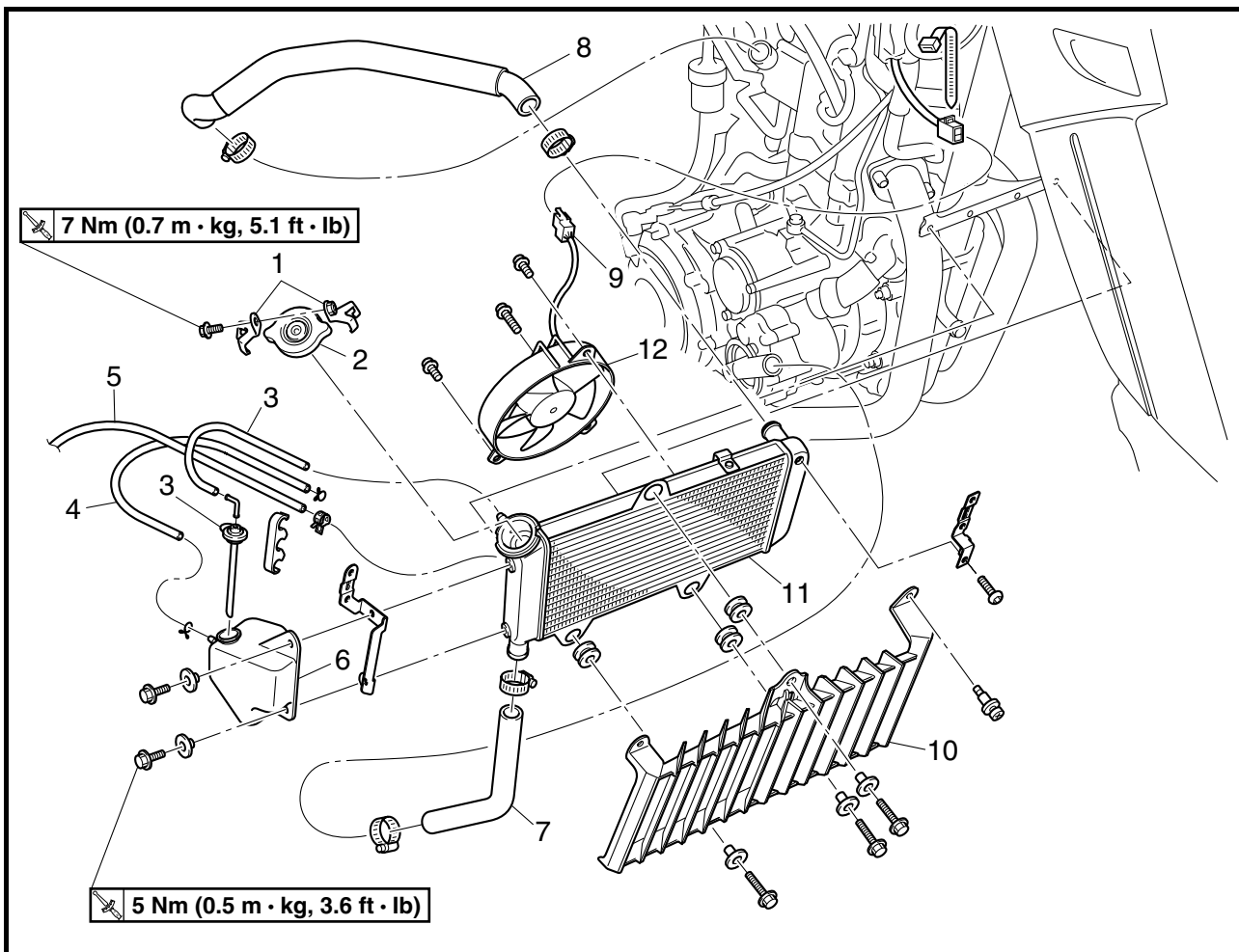

Order	Job/Part	Q'ty	Remarks
	Removing the radiator (XT660X)		Remove the parts in the order listed.
	Seat/side panels (left and right)		Refer to "COWLING AND COVER".
	Fuel tank side covers (left and right)/ fuel tank		Refer to "FUEL TANK".
	Coolant		Drain.
			Refer to "CHANGING THE COOLANT" in chapter 3. (Manual No.: 5VK1-AE1)
1	Radiator cap retainer	2	
2	Radiator cap	1	
3	Coolant reservoir hose/cap	1/1	
4	Coolant reservoir breather hose	1	
5	Fast idle plunger outlet hose	1	Disconnect.
6	Coolant reservoir	1	

RADIATOR

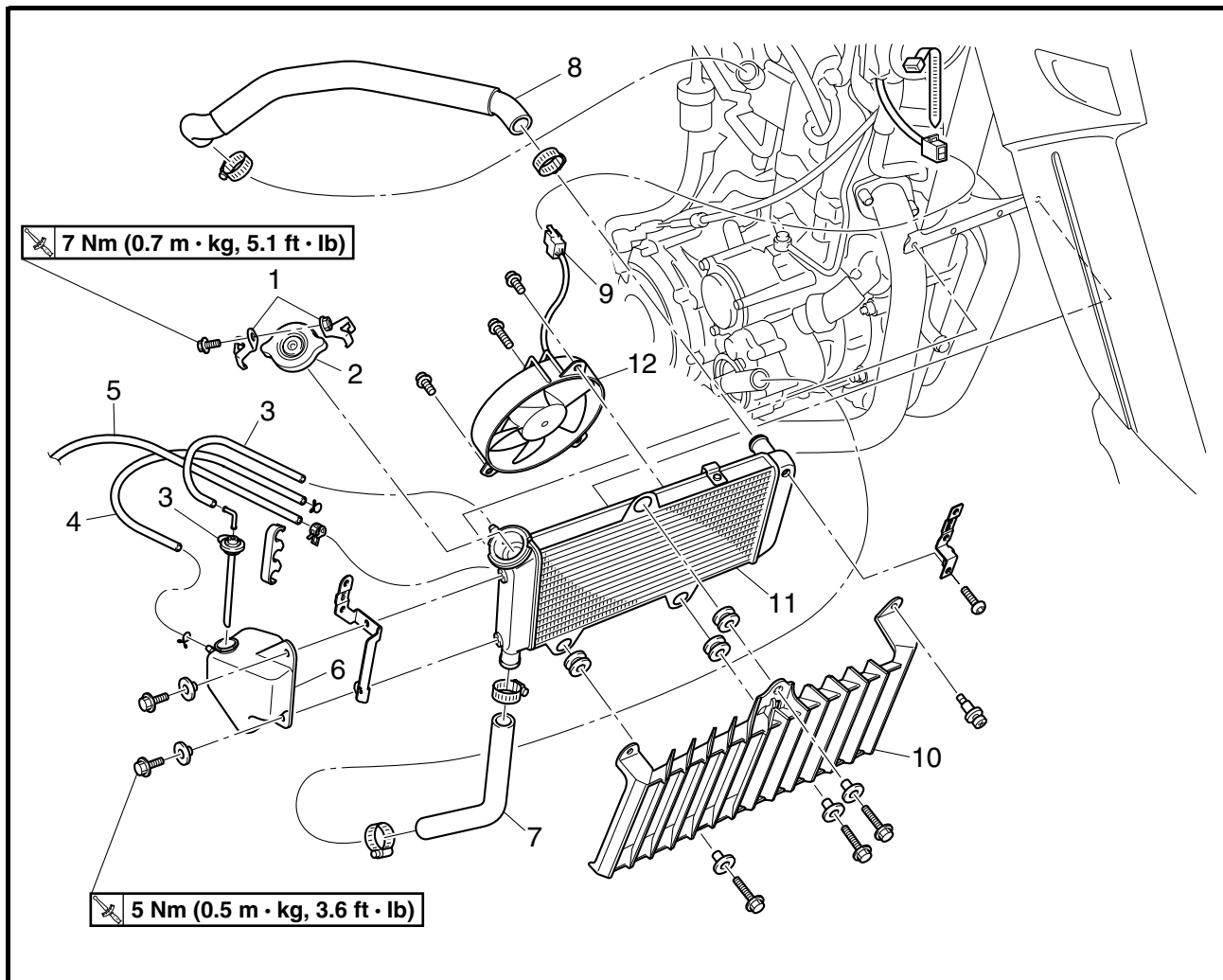
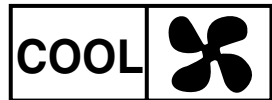

Order	Job/Part	Q'ty	Remarks
7	Radiator outlet hose	1	Refer to "INSTALLING THE RADIATOR" in chapter 6. (Manual No.: 5VK1-AE1)
8	Radiator inlet hose	1	
9	Radiator fan motor coupler	1	Disconnect.
10	Radiator guard	1	
11	Radiator	1	
12	Radiator fan	1	
			For installation, reverse the removal procedure.

FUEL INJECTION SYSTEM

FI



EAS00894

FUEL INJECTION SYSTEM

EAS00895

FUEL INJECTION SYSTEM

- | | | |
|---|---------------------------------|------------------------------|
| ① Air cut-off valve | ⑨ Intake air temperature sensor | ⑱ Coolant temperature sensor |
| ② Air induction system solenoid | ⑩ Air filter case | ⑲ Spark plug |
| ③ Engine trouble warning light | ⑪ Fuel injection system relay | ⑳ O ₂ sensor |
| ④ Fuel tank | ⑫ Battery | ㉑ Intake air pressure sensor |
| ⑤ Fuel pump (include fuel pressure regulator) | ⑬ Catalytic converter | ㉒ Ignition coil |
| ⑥ Fuel hose | ⑭ ECU | |
| ⑦ Fuel injector | ⑮ Lean angle cut-off switch | |
| ⑧ Throttle position sensor | ⑯ Fast idle plunger | |
| | ⑰ Crankshaft position sensor | |

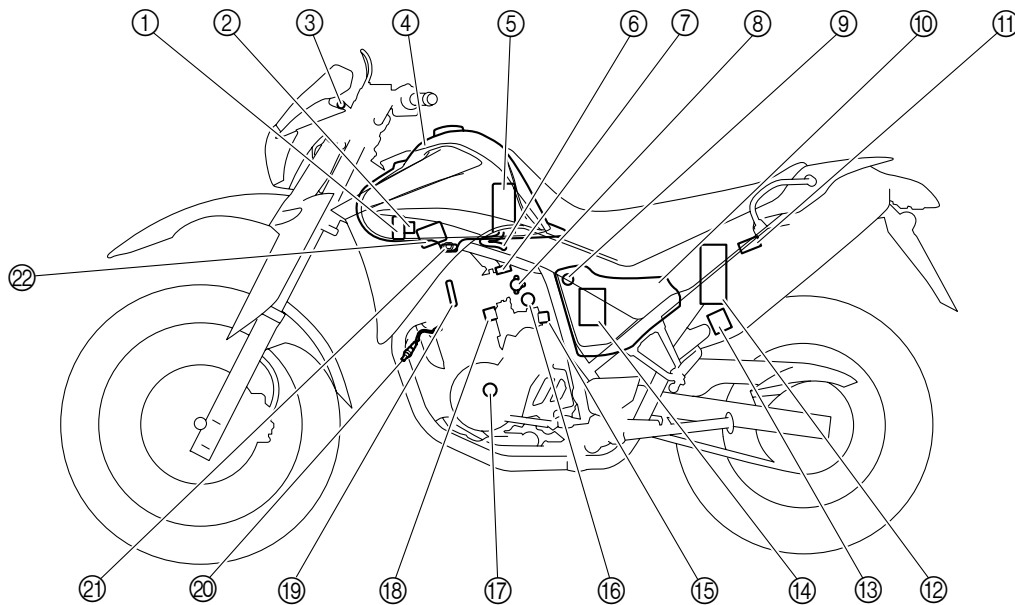

FUEL INJECTION SYSTEM

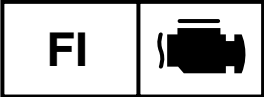

EAS00898

WIRING DIAGRAM

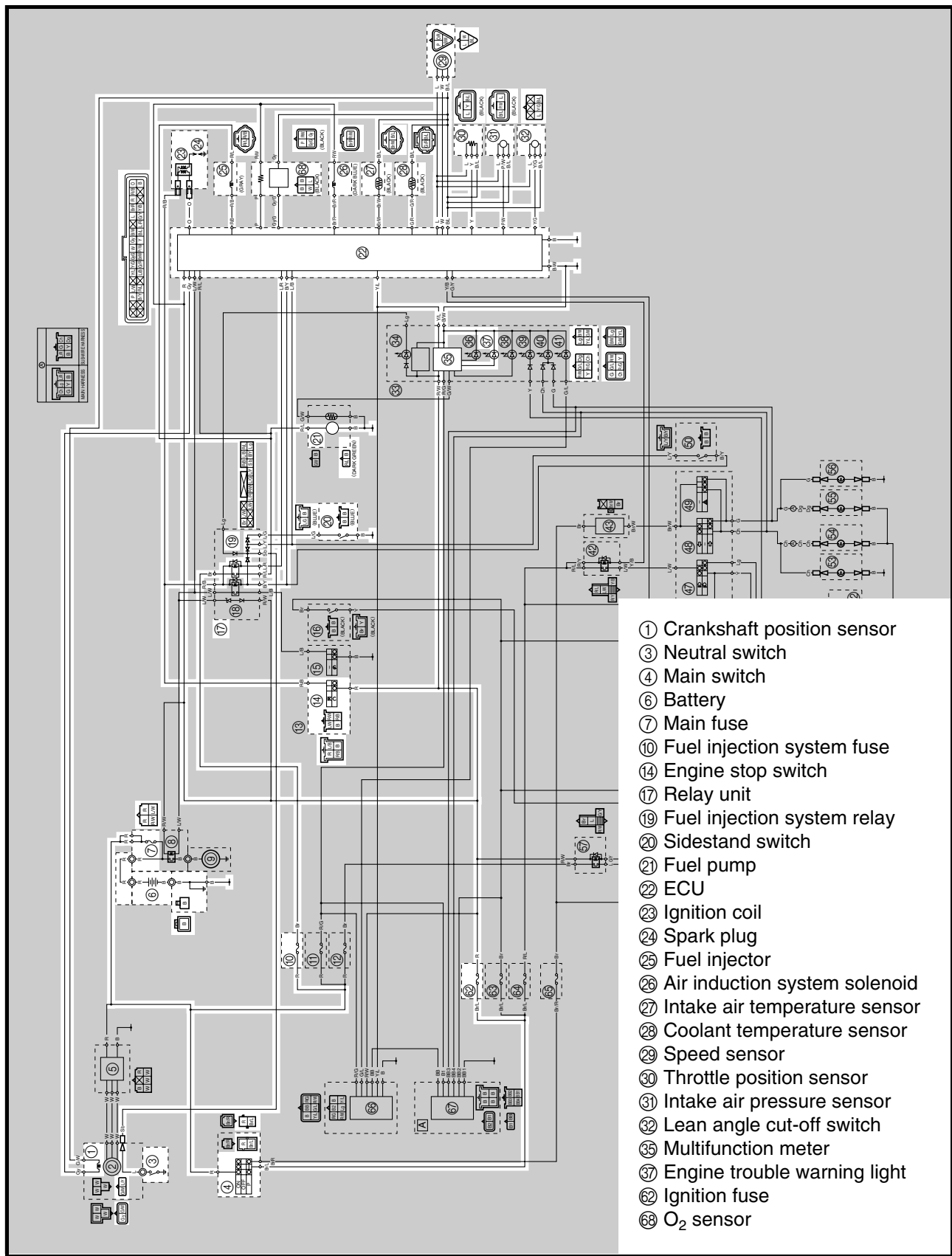

- ① Crankshaft position sensor
- ③ Neutral switch
- ④ Main switch
- ⑥ Battery
- ⑦ Main fuse
- ⑩ Fuel injection system fuse
- ⑭ Engine stop switch
- ⑰ Relay unit
- ⑱ Fuel injection system relay
- ⑳ Sidestand switch
- ㉑ Fuel pump
- ㉒ ECU
- ㉓ Ignition coil
- ㉔ Spark plug
- ㉕ Fuel injector
- ㉖ Air induction system solenoid
- ㉗ Intake air temperature sensor
- ㉘ Coolant temperature sensor
- ㉙ Speed sensor
- ㉚ Throttle position sensor
- ㉛ Intake air pressure sensor
- ㉜ Lean angle cut-off switch
- ㉝ Multifunction meter
- ㉞ Engine trouble warning light
- ㉟ Ignition fuse
- ㊱ O₂ sensor

FUEL INJECTION SYSTEM**FI****FAIL-SAFE ACTION TABLE****Self-diagnostic function**

Fault code No.	Item	Symptom	Fail-safe action	Startability	Driveability
12	Crankshaft position sensor	No normal signals are received from the sensor.	—	No	No
13	Intake air pressure sensor (open or short circuit)	Open or short circuit is detected.	• Fixes the intake air pressure to 101 kPa (760 mmHg, 29.9 inHg).	Yes	Yes
14	Intake air pressure sensor	Intake air pressure sensor hose is clogged or disconnected, causing the constant application of atmospheric pressure to the sensor.	• Fixes the intake air pressure to 101 kPa (760 mmHg, 29.9 inHg).	Yes	Yes
15	Throttle position sensor (open or short circuit)	Open or short circuit is detected.	• Fixes the throttle position sensor to fully open.	Yes	Yes
16	Throttle position sensor (stuck)	The throttle position sensor is detected stuck.	• Fixes the throttle position sensor to fully open.	Yes	Yes
19	Broken or disconnected blue/black lead of the ECU	Open circuit in the input line (blue/black) of the ECU is detected.	—	No	No
21	Coolant temperature sensor	Open or short circuit is detected.	• Fixes the coolant temperature to 80 °C (176 °F).	Yes	Yes
22	Intake air temperature sensor	Open or short circuit is detected.	• Fixes the intake air temperature to 20 °C (68 °F).	Yes	Yes
24	O ₂ sensor	No normal signal is received from the O ₂ sensor.	—	Yes	Yes
30	Lean angle cut-off switch (latch up detected)	The motorcycle has overturned.	—	No	No
31	O ₂ sensor	The amount of air-fuel ratio feedback compensation is maintained continuously in the vicinity of the upper limit (lean air-fuel ratio).	—	Yes	Yes
32	O ₂ sensor	The amount of air-fuel ratio feedback compensation is maintained continuously in the vicinity of the lower limit (rich air-fuel ratio).	—	Yes	Yes
33	Faulty ignition	Open circuit is detected in the primary lead of the ignition coil.	—	No	No
41	Lean angle cut-off switch (open or short circuit)	Open or short circuit is detected.	—	No	No
42	Speed sensor, neutral switch	No normal signals are received from the speed sensor or an open or short circuit is detected in the neutral switch.	• Fixes the gear to the top gear.	Yes	Yes
43	Fuel system voltage (monitor voltage)	The ECU is unable to monitor the battery voltage (open circuit in the wire to the ECU).	• Fixes the battery voltage to 12 V.	Yes	Yes
44	Error in writing the amount of CO adjustment on EEPROM	An error is detected while reading or writing on EEPROM (CO adjustment value).	—	Yes	Yes

FUEL INJECTION SYSTEM

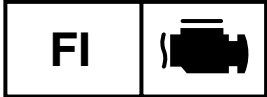

Fault code No.	Item	Symptom	Fail-safe action	Startability	Driveability
46	Vehicle system power supply (monitor voltage)	Power supply to the fuel injection system relay is not normal.	—	Yes	Yes
50	ECU internal malfunction (memory check error)	Faulty ECU memory. When this malfunction is detected, the code number might not appear on the meter.	—	No	Yes
—	Start unable warning	Relay is not turned ON even if the crank signal is input while the start switch is turned ON. When the start switch is turned ON while an error is detected with the fault code of No. 12, 19, 33, 41 or 50.	<ul style="list-style-type: none"> • Engine trouble warning light flashes when the start switch is turned ON. 	No	No

Communication error with the meter

Fault code No.	Item	Symptom	Fail-safe action	Startability	Driveability
Er-1	ECU internal malfunction (output signal error)	No signals are received from the ECU.	—	No	No
Er-2	ECU internal malfunction (output signal error)	No signals are received from the ECU within the specified duration.	—	No	No
Er-3	ECU internal malfunction (output signal error)	Data from the ECU cannot be received correctly.	—	No	No
Er-4	ECU internal malfunction (input signal error)	Non-registered data has been received from the meter.	—	No	No

FUEL INJECTION SYSTEM

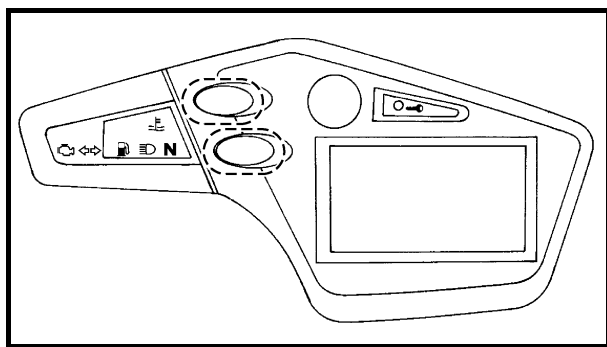

EAS00905

DIAGNOSTIC MODE

Setting the diagnostic mode

1. Set the main switch to “OFF” and set the engine stop switch to “○”.
2. Disconnect the wire harness coupler from the fuel pump.
3. Simultaneously press and hold the “SELECT” and “RESET” buttons, turn the main switch to “ON”, and continue to press the buttons for 8 seconds or more.

NOTE:

All displays on the meter disappear “dIAG” appears on the odometer/fuel reserve tripmeter/tripmeter 2 LCD.

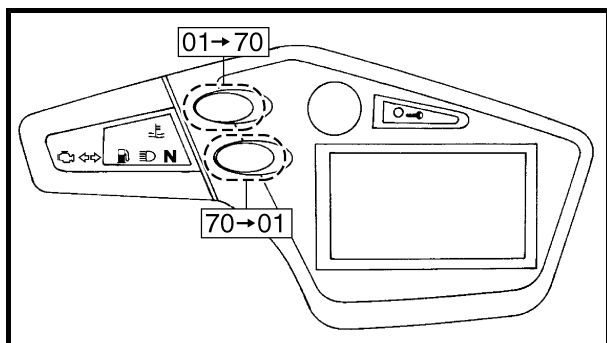

4. Press the “SELECT” button to select the CO adjustment mode “Co” or the diagnostic mode “dIAG”.
5. After selecting “dIAG”, simultaneously press the “SELECT” and “RESET” buttons for 2 seconds or more to execute the selection.
6. Set the engine stop switch to “⊗”.
7. Select the diagnostic code number that applies to the item that was verified with the fault code number by pressing the “SELECT” and “RESET” buttons.

NOTE:

The diagnostic code number appears on the odometer/fuel reserve tripmeter/tripmeter 2 LCD (01-70).

- To decrease the selected diagnostic code number, press the “SELECT” button. Press the “SELECT” button for 1 second or longer to automatically decrease the diagnostic code numbers.
- To increase the selected diagnostic code number, press the “RESET” button. Press the “RESET” button for 1 second or longer to automatically increase the diagnostic code numbers.

FUEL INJECTION SYSTEM

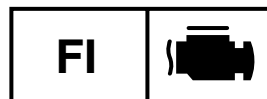

8. Verify the operation of the sensor or actuator.

- Sensor operation

The data representing the operating conditions of the sensor appears on the odometer/fuel reserve tripmeter/tripmeter 2 LCD.

- Actuator operation

Set the engine stop switch to “○” to operate the actuator.

NOTE: _____

If the engine stop switch is set to “○”, set it to “⊗”, and then set it to “○” again.

9. Set the main switch to “OFF” to cancel the diagnostic mode.

FUEL INJECTION SYSTEM**FI**

EAS00906

Diagnostic monitoring code table

Fault code No.	Symptom	Probable cause of malfunction	Diagnostic code
12	No normal signals are received from the crankshaft position sensor.	<ul style="list-style-type: none"> • Open or short circuit in wire harness • Defective crankshaft position sensor • Disconnected crankshaft position sensor coupler • Malfunction in A.C. magneto rotor • Malfunction in ECU • Improperly installed crankshaft position sensor 	—
13	Open or short circuit is detected in the intake air pressure sensor.	<ul style="list-style-type: none"> • Open or short circuit in wire harness • Defective intake air pressure sensor • Disconnected intake air pressure sensor coupler • Malfunction in ECU 	03
14	Faulty intake air pressure sensor hose system. <ul style="list-style-type: none"> • detected hose • clogged hose 	<ul style="list-style-type: none"> • Disconnected, clogged, kinked, or pinched intake air pressure sensor hose • Defective intake air pressure sensor • Malfunction in ECU 	03
15	Open or short circuit is detected in the throttle position sensor.	<ul style="list-style-type: none"> • Open or short circuit in wire harness • Defective throttle position sensor • Disconnected throttle position sensor coupler • Malfunction in ECU • Improperly installed throttle position sensor 	01
16	Stuck throttle position sensor is detected.	<ul style="list-style-type: none"> • Stuck throttle position sensor • Improperly installed throttle position sensor • Malfunction in ECU 	01
19	Open circuit in the input line (blue/black lead) of ECU is detected when the start switch is pushed.	<ul style="list-style-type: none"> • Open circuit in wire harness (ECU coupler) • Malfunction in ECU 	20
21	Open or short circuit is detected in the coolant temperature sensor.	<ul style="list-style-type: none"> • Open or short circuit in wire harness • Defective coolant temperature sensor • Disconnected coolant temperature sensor coupler • Malfunction in ECU • Improperly installed coolant temperature sensor 	06
22	Open or short circuit is detected in the intake air temperature sensor.	<ul style="list-style-type: none"> • Open or short circuit in wire harness • Defective intake air temperature sensor • Disconnected intake air temperature sensor coupler • Malfunction in ECU • Improperly installed intake air temperature sensor 	05
24	No normal signal is received from the O ₂ sensor.	<ul style="list-style-type: none"> • Open or short circuit in wire harness. • Defective O₂ sensor. • Improperly installed sensor. • Malfunction in ECU. 	—
30	The motorcycle has overturned.	<ul style="list-style-type: none"> • Overturned motorcycle • Malfunction in ECU 	08
31	The amount of air-fuel ratio feedback compensation is maintained continuously in the vicinity of the upper limit (lean air-fuel ratio).	<ul style="list-style-type: none"> • Open or short circuit in wiring harness. • Fuel pressure too low. • Clogged injectors. • Defective O₂ sensor (unable to output a rich signal). • Malfunction in other areas of the fuel system. • Malfunction in ECU. 	—
32	The amount of air-fuel ratio feedback compensation is maintained continuously in the vicinity of the lower limit (rich air-fuel ratio).	<ul style="list-style-type: none"> • Open or short circuit in wiring harness. • Fuel pressure too high. • Faulty injectors (excessive injection volume). • Defective O₂ sensor (unable to output a lean signal). • Malfunction in other areas of the fuel system. • Malfunction in ECU. 	—
33	Open circuit is detected in the primary lead of the ignition coil.	<ul style="list-style-type: none"> • Open circuit in wire harness • Malfunction in ignition coil • Malfunction in ECU • Malfunction in a component of ignition cut-off circuit system 	30

FUEL INJECTION SYSTEM

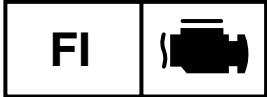

Fault code No.	Symptom	Probable cause of malfunction	Diagnostic code
41	Open or short circuit is detected in the lean angle cut-off switch.	<ul style="list-style-type: none"> • Open or short circuit in wire harness • Defective lean angle cut-off switch • Disconnected lean angle cut-off switch coupler • Malfunction in ECU 	08
42	No normal signals are received from the speed sensor or an open or short circuit is detected in the neutral switch.	<ul style="list-style-type: none"> • Open or short circuit in wire harness • Defective speed sensor • Disconnected speed sensor coupler • Malfunction in vehicle speed sensor detected unit • Defective neutral switch • Disconnected neutral switch connector • Malfunction in the engine side of the neutral switch • Malfunction in ECU 	07 21
43	Power supply to the injector and fuel pump is not normal. (The ECU is unable to monitor the battery voltage.)	<ul style="list-style-type: none"> • Open circuit in wire harness • Malfunction in ECU • Defective fuel injection system relay 	09, 50
44	An error is detected while reading or writing on EEPROM.	<ul style="list-style-type: none"> • Malfunction in ECU (The CO adjustment value is not properly written on or read from the internal memory.) 	60
46	Power supply to the fuel injection system relay is not normal.	<ul style="list-style-type: none"> • Open circuit in wire harness • Malfunction in rectifier/regulator • Malfunction in A.C. magneto rotor Refer to "CHARGING SYSTEM" in chapter 8. (Manual No.: 5VK1-AE1)	09
50	Faulty ECU memory. When this malfunction is detected, the code number might not appear on the meter.	<ul style="list-style-type: none"> • Malfunction in ECU (The program and data are not properly written on or read from the internal memory.) 	—
Er-1	No signals are received from the ECU.	<ul style="list-style-type: none"> • Open or short circuit in sub-wire harness • Disconnected ECU coupler • Malfunction in meter • Malfunction in ECU 	—
Er-2	No signals are received from the ECU within the specified duration.	<ul style="list-style-type: none"> • Improper connection in sub-wire harness • Disconnected ECU coupler • Malfunction in meter • Malfunction in ECU 	—
Er-3	Data from the ECU cannot be received correctly.	<ul style="list-style-type: none"> • Improper connection in sub-wire harness • Disconnected ECU coupler • Malfunction in meter • Malfunction in ECU 	—
Er-4	Non-registered data has been received from the meter.	<ul style="list-style-type: none"> • Improper connection in sub-wire harness • Disconnected ECU coupler • Malfunction in meter • Malfunction in ECU 	—

FUEL INJECTION SYSTEM**FI**

EAS00907

Diagnostic mode table

Switch the meter display from the regular mode to the diagnostic mode. To switch the display, refer to "DIAGNOSTIC MODE".

NOTE:

- Check the intake air temperature and coolant temperature as close as possible to the intake air temperature sensor and the coolant temperature sensor respectively.
- If it is not possible to check the intake air temperature, use the ambient temperature as reference.

Diagnostic code	Item	Action	Data displayed on meter (reference value)
01	Throttle angle	Displays the throttle angle. • Check with throttle fully closed. • Check with throttle fully open.	0 ~ 125 degrees • Fully closed (15 ~ 17 degrees) • Fully open (97 ~ 100 degrees)
03	Intake air pressure	Displays the intake air pressure. Set the engine stop switch to "○". • Generate the pressure difference by cranking the engine with the start switch, but do not start the engine.	When the engine is stopped: Atmospheric pressure 101.3 kPa (760 mmHg, 30 inHg) When cranking the engine with start switch: 1.3 ~ 26.6 kPa (10 ~ 200 mmHg, 0.4 ~ 7.9 inHg)
05	Intake air temperature	Displays the intake air temperature. • Check the temperature in the air filter case.	Compare the temperature in the air filter case to the value displayed on the meter.
06	Coolant temperature	Displays the coolant temperature. • Check the coolant temperature.	Compare the coolant temperature to the value displayed on the meter.
07	Vehicle speed pulse	Displays the accumulation of the vehicle speed pulses that are generated when the tire is spun.	(0 ~ 199; resets to 0 after 199) OK if the numbers appear on the meter.
08	Lean angle cut-off switch	Displays the lean angle cut-off switch values.	Upright: 0.4 ~ 1.4 V Overturned: 3.7 ~ 4.4 V
09	Fuel system voltage (battery voltage)	Displays the fuel system voltage (battery voltage). Set the engine stop switch to "○".	Approximately 12.0 V
20	Sidestand switch	Displays that the switch is on or off. (When the gear is in a position other than neutral.)	Stand retracted: On Stand extended: Off
21	Neutral switch	Displays that the switch is on or off.	Neutral: On In gear: Off
30	Ignition coil	The engine stop switch is set to "○", the ignition coil operates 5 times every second and the engine trouble warning light comes on. • Connect an ignition checker to the spark plug cap. • If the engine stop switch is set to "○", set it to "⊗", and then set it to "○" again.	Check that sparks are generated 5 times with the engine stop switch is set to "○".
36	Fuel injector	The engine stop switch is set to "○", the fuel injector operates 5 times every second and the engine trouble warning light comes on. • If the engine stop switch is set to "○", set it to "⊗", and then set it to "○" again.	Check that the operating sound of the fuel injector is generated 5 times when the engine stop switch is set to "○".
48	Air induction system	The engine stop switch is set to "○", the air induction system solenoid operates 5 times every second and the engine trouble warning light comes on. • If the engine stop switch is set to "○", set it to "⊗", and then set it to "○" again.	Check that the operating sound of the air induction system solenoid is generated 5 times when the engine stop switch is set to "○".
50	Fuel injection system relay	The engine stop switch is set to "○", the fuel injection system relay operates 5 times every second and the engine trouble warning light comes on (on when relay is operating, off when relay is not operating). • If the engine stop switch is set to "○", set it to "⊗", and then set it to "○" again.	Check that the operating sound of the fuel injection system relay is generated 5 times when the engine stop switch is set to "○".

FUEL INJECTION SYSTEM

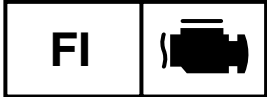

Diagnostic code	Item	Action	Data displayed on meter (reference value)
51	Radiator fan motor relay	<p>The engine stop switch is set to “○”, the radiator fan motor relay operates 5 times, 5 seconds each time (2 seconds on, 3 seconds off), and the engine trouble warning light comes on.</p> <ul style="list-style-type: none"> • If the engine stop switch is set to “○”, set it to “⊗”, and then set it to “○” again. 	Check that the operating sound of the radiator fan motor relay is generated and that the radiator fan motor is operated 5 times when the engine stop switch is set to “○”.
52	Headlight relay 1	<p>The engine stop switch is set to “○”, the headlight relay operates 5 times, 5 seconds each time (2 seconds on, 3 seconds off), and the engine trouble warning light comes on.</p> <ul style="list-style-type: none"> • If the engine stop switch is set to “○”, set it to “⊗”, and then set it to “○” again. 	Check that the operating sound of the headlight relay is generated and that the headlight comes on 5 times when the engine stop switch is set to “○”.
60	E2PROM fault code display	<ul style="list-style-type: none"> • Transmits the abnormal portion of the data in the E2PROM that has been detected as fault code 44. 	01 “00” is displayed when there is no malfunction.
61	Malfunction history code display	<ul style="list-style-type: none"> • Displays the codes of the history of the self-diagnosis malfunctions (i.e., a code of a malfunction that occurred once and which has been corrected). • If multiple malfunctions have been detected, different codes are displayed at 2-second intervals, and this process is repeated. 	12 ~ 61 “00” is displayed when there is no malfunction.
62	Malfunction history code erasure	<ul style="list-style-type: none"> • Displays the total number of codes that are being detected through self diagnosis and the fault codes in the past history. • Erases only the history codes when the engine stop switch is set to “○”. If the engine stop switch is set to “○”, set it to “⊗”, and then set it to “○” again. 	00 ~ 17 “00” is displayed when there is no malfunction.
70	Control number	<ul style="list-style-type: none"> • Displays the program control number. 	00 ~ 255

FUEL INJECTION SYSTEM

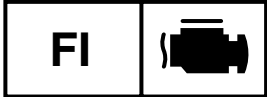

EAS00908

TROUBLESHOOTING DETAILS

This section describes the countermeasures per fault code number displayed on the meter. Check and service the items or components that are the probable cause of the malfunction following the order in the “TROUBLESHOOTING CHART” in chapter 7. (Manual No.: 5VK1-AE1)

After the checking and servicing the malfunctioning part, reset the meter display. Refer to “Restore method”.

Fault code No.:

Fault code number displayed on the meter when the engine failed to work normally. Refer to “Diagnostic monitoring code table”.



Diagnostic code No.:

Diagnostic code number to be used when the diagnostic mode is operated. Refer to “DIAGNOSTIC MODE”.

Fault code No.	12	Symptom	No normal signals are received from the crankshaft position sensor.	
Used diagnostic code No. --				
Order	Item/components	Check or maintenance job	Restore method	
1	Crankshaft position sensor installation	Check the sensor for looseness or pinching.	Reinstated by cranking the engine.	
2	Coupler connections Crankshaft position sensor coupler ECU coupler	Check the couplers for any pins that may have pulled out. Check that the couplers are securely locked. If necessary, repair the coupler or securely connect it.		
3	Open or short circuit in the wire harness	Repair or replace if there is an open or short circuit between the wire harnesses. Gray - Gray Green/White - Black/Blue		
4	Defective crankshaft position sensor	Replace the sensor if it is defective. Refer to “IGNITION SYSTEM” in chapter 8. (Manual No.: 5VK1-AE1)		

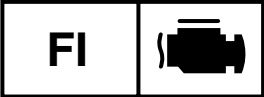
FUEL INJECTION SYSTEM

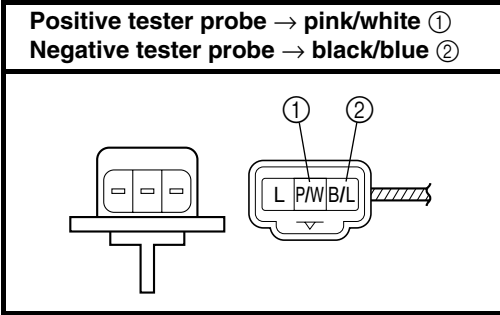

Fault code No.	13	Symptom	Open or short circuit is detected from the intake air pressure sensor.	
Used diagnostic code No. 03 (intake air pressure sensor)				
Order	Item/components	Check or maintenance job	Restore method	
1	Coupler connections Intake air pressure sensor coupler ECU coupler Sub-wire harness coupler	Check the couplers for any pins that may have pulled out. Check that the couplers are securely locked. If necessary, repair the coupler or securely connect it.	Reinstated by cranking the engine.	
2	Open or short circuit in the wire harness	Repair or replace if there is an open or short circuit between the wire harnesses. Black/Blue - Black/Blue Pink/White - Pink/White Blue - Blue		
3	Defective intake air pressure sensor	Execute the diagnostic mode. (Code No. 03) Replace the sensor if it is defective. 1. Connect the pocket tester (DC 20 V) to the intake air pressure sensor coupler (wire harness end) as shown.		
		<p>Positive tester probe → pink/white ① Negative tester probe → black/blue ②</p> 		
		2. Set the main switch to "ON". 3. Measure the intake air pressure sensor output voltage.		
		 <p>Intake air pressure sensor output voltage 3.4 ~ 3.8 V</p>		
		4. Is the intake air pressure sensor OK?		

FUEL INJECTION SYSTEM

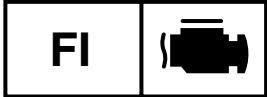

Fault code No.	14	Symptom	Intake air pressure sensor hose is disconnected or clogged.	
Used diagnostic code No. 03 (intake air pressure sensor)				
Order	Item/components	Check or maintenance job		Restore method
1	Disconnected, clogged, kinked, or pinched intake air pressure sensor hose Intake air pressure sensor malfunction at intermediate electrical potential	Repair or replace the hose.		Reinstated by starting the engine and operating it at idle.
		Check and repair the connection.		
		Replace the sensor if there is a malfunction.		
2	Coupler connections Intake air pressure sensor coupler ECU coupler	Check the couplers for any pins that may have pulled out. Check that the couplers are securely locked. If necessary, repair the coupler or securely connect it.		
3	Defective intake air pressure sensor	Execute the diagnostic mode. (Code No. 03) Replace the sensor if it is defective. Refer to "Fault code No. 13".		

Fault code No.	15	Symptom	Open or short circuit is detected from the throttle position sensor.	
Used diagnostic code No. 01 (throttle position sensor)				
Order	Item/components	Check or maintenance job		Restore method
1	Throttle position sensor installation	Check the sensor for looseness or pinching. Check that the sensor is installed in the specified position.		Reinstated by setting the main switch to "ON".
2	Coupler connections Throttle position sensor coupler ECU coupler	Check the connections of the couplers. Check that the couplers are securely locked. If necessary, repair the coupler or securely connect it.		
3	Open or short circuit in the wire harness	Repair or replace if there is an open or short circuit between the wire harnesses. Black/Blue - Black/Blue Yellow - Yellow Blue - Blue		
4	Check the throttle position sensor lead open circuit output voltage.	Check for an open circuit and replace the throttle position sensor, if necessary. Black/Blue - Yellow		
		Open circuit item	Output voltage	
		Ground wire open circuit	5 V	
		Output wire open circuit	0 V	
	Power supply wire open circuit	0 V		
5	Defective throttle position sensor	Execute the diagnostic mode. (Code No. 01) Replace the sensor if it is defective. Refer to "THROTTLE BODY ASSEMBLY" in chapter 7. (Manual No.: 5VK1-AE1)		

FUEL INJECTION SYSTEM





Fault code No.	16	Symptom	The throttle position sensor is detected stuck.	
Used diagnostic code No. 01 (throttle position sensor)				
Order	Item/components	Check or maintenance job	Restore method	
1	Defective throttle position sensor	Replace the sensor if it is defective. Refer to "THROTTLE BODY ASSEMBLY" in chapter 7. (Manual No.: 5VK1-AE1)	Reinstated by starting the engine, operating it at idle, and then racing it.	
2	Throttle position sensor installation	Execute the diagnostic mode. (Code No. 01) Check the sensor for looseness or pinching. Check that the sensor is installed in the specified position. Refer to "THROTTLE BODY ASSEMBLY" in chapter 7. (Manual No.: 5VK1-AE1)		

Fault code No.	19	Symptom	Open circuit is detected in the input wire from the sidestand switch to the ECU.	
Used diagnostic code No. 20 (sidestand switch)				
Order	Item/components	Check or maintenance job	Restore method	
1	Coupler connections ECU coupler Blue/Black connector	Check the couplers for any pins that may have pulled out. Check that the couplers are securely locked. If necessary, repair the coupler or securely connect it.	If the transmission is in gear, it is reinstated by retracting the sidestand. If the transmission is in neutral, it is reinstated by reconnecting the wiring.	
2	Open or short circuit in the wire harness	Repair or replace if there is an open or short circuit between the ECU and sidestand switch. Blue/Black		
3	Defective sidestand switch	Execute the diagnostic mode. (Code No. 20) Replace the switch if it is defective. Refer to "CHECKING THE SWITCHES" in chapter 8. (Manual No.: 5VK1-AE1)		

Fault code No.	21	Symptom	Open or short circuit is detected from the coolant temperature sensor.	
Used diagnostic code No. 06 (coolant temperature sensor)				
Order	Item/components	Check or maintenance job	Restore method	
1	Coolant temperature sensor installation	Check the sensor for looseness or pinching.	Reinstated by setting the main switch to "ON".	
2	Coupler connections Coolant temperature sensor coupler ECU coupler	Check the coupler for any pins that may have pulled out. Check that the couplers are securely locked. If necessary, repair the coupler or securely connect it.		
3	Open or short circuit in the wire harness	Repair or replace if there is an open or short circuit between the wire harnesses. Black/Blue - Black/Blue Green/Red - Green/Red		
4	Defective coolant temperature sensor	Execute the diagnostic mode. (Code No. 06) Replace the sensor if it is defective. Refer to "COOLING SYSTEM" in chapter 8. (Manual No.: 5VK1-AE1)		

FUEL INJECTION SYSTEM

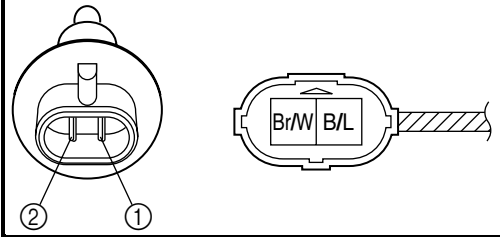

Fault code No.	22	Symptom	Open or short circuit is detected from the intake air temperature sensor.	
Used diagnostic code No. 05 (intake air temperature sensor)				
Order	Item/components	Check or maintenance job	Restore method	
1	Intake air temperature sensor installation	Check the sensor looseness or pinching.	Reinstated by setting the main switch to "ON".	
2	Coupler connections Intake air temperature sensor coupler ECU coupler	Check the couplers for any pins that may have pulled out. Check that the couplers are securely locked. If necessary, repair the coupler or securely connect it.		
3	Open or short circuit in the wire harness	Repair or replace if there is an open or short circuit between the wire harnesses. Black/Blue - Black/Blue Brown/White - Brown/White		
4	Defective intake air temperature sensor	<p>Execute the diagnostic mode. (Code No. 05) Replace the sensor if it is defective.</p> <ol style="list-style-type: none"> 1. Remove the intake air temperature sensor from the air filter case. 2. Connect the pocket tester ($\Omega \times 100$) to the intake air temperature sensor terminal as shown. <div style="border: 1px solid black; padding: 5px; margin: 5px 0;"> <p>Positive tester probe → brown/white ① Negative tester probe → black/blue ②</p>  </div> <ol style="list-style-type: none"> 3. Measure the intake air temperature sensor resistance. <div style="border: 1px solid black; padding: 5px; margin: 5px 0;">  <p>Intake air temperature sensor resistance 2.21 ~ 2.69 Ω at 20 °C (68 °F)</p> </div> <div style="border: 1px solid black; padding: 5px; margin: 5px 0;"> <p>⚠ WARNING</p> <ul style="list-style-type: none"> • Handle the intake air temperature sensor with special care. • Never subject the intake air temperature sensor to strong shocks. If the intake air temperature sensor is dropped, replace it. </div> <ol style="list-style-type: none"> 4. Is the intake air temperature sensor OK? 		

FUEL INJECTION SYSTEM

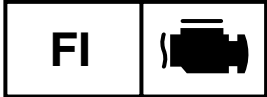

Fault code No.	24	Symptom	No normal signal is received from the O ₂ sensor.	
Used diagnostic code No. --				
Order	Item/components	Check or maintenance job	Restore method	
1	Installed state of O ₂ sensor.	Check for looseness or pinching.	Starting the engine and operating it at idle.	
2	Connections O ₂ sensor coupler ECU coupler	Check the coupler for any pins that may be pulled out. Check the locking condition of the coupler. If there is a malfunction, repair it and connect the coupler securely.		
3	Open or short circuit in wire harness.	Repair or replace if there is an open or short circuit. Between O ₂ sensor coupler and ECU coupler. Pink - Pink Red/White - Red Gray - Black/Blue Gray/Green - Gray/Green		
4	Check fuel pressure.	Refer to "THROTTLE BODY ASSEMBLY" in chapter 7. (Manual No.: 5VK1-AE1)		
5	Defective O ₂ sensor.	Replace if defective.		

Fault code No.	30	Symptom	The motorcycle has overturned.	
Used diagnostic code No. 08 (lean angle cut-off switch)				
Order	Item/components	Check or maintenance job	Restore method	
1	The motorcycle has overturned.	Raise the motorcycle upright.	Reinstated by setting the main switch to "ON" (the engine cannot be started unless the main switch is first set to "OFF").	
2	Lean angle cut-off switch installation	Check the switch for looseness or pinching.		
3	Coupler connections Lean angle cut-off switch coupler ECU coupler	Check the coupler for any pins that may have pulled out. Check that the couplers are securely locked. If necessary, repair the coupler or securely connect it.		
4	Defective lean angle cut-off switch	Execute the diagnostic mode. (Code No. 08) Replace the switch if it is defective. Refer to "IGNITION SYSTEM" in chapter 8. (Manual No.: 5VK1-AE1)		

FUEL INJECTION SYSTEM



Fault code No.	31	Symptom	The amount of air-fuel ratio feedback compensation is maintained continuously in the vicinity of the upper limit.	
Used diagnostic code No. --				
Order	Item/components	Check or maintenance job	Restore method	
1	Installed state of O ₂ sensor.	Check for looseness or pinching.	Starting the engine and operating it at idle.	
2	Connections O ₂ sensor coupler ECU coupler	Check the coupler for any pins that may be pulled out. Check the locking condition of the coupler. If there is a malfunction, repair it and connect the coupler securely.		
3	Open or short circuit in wire harness.	Repair or replace if there is an open or short circuit. Between O ₂ sensor coupler and ECU coupler. Pink - Pink Red/White - Red Gray - Black/Blue Gray/Green - Gray/Green		
4	Check fuel pressure.	Refer to "THROTTLE BODY ASSEMBLY" in chapter 7. (Manual No.: 5VK1-AE1)		
5	Defective O ₂ sensor. (Unable to output a rich signal)	Replace if defective.		

Fault code No.	32	Symptom	The amount of air-fuel ratio feedback compensation is maintained continuously in the vicinity of the lower limit (air-fuel ratio is rich).	
Used diagnostic code No. --				
Order	Item/components	Check or maintenance job	Restore method	
1	Installed state of O ₂ sensor.	Check for looseness or pinching.	Starting the engine and operating it at idle.	
2	Connections O ₂ sensor coupler ECU coupler	Check the coupler for any pins that may be pulled out. Check the locking condition of the coupler. If there is a malfunction, repair it and connect the coupler securely.		
3	Open or short circuit in wire harness.	Repair or replace if there is an open or short circuit. Between O ₂ sensor coupler and ECU coupler. Pink - Pink Red/White - Red Gray - Black/Blue Gray/Green - Gray/Green		
4	Check fuel pressure.	Refer to "THROTTLE BODY ASSEMBLY" in chapter 7. (Manual No.: 5VK1-AE1)		
5	Defective O ₂ sensor. (Unable to output a lean signal)	Replace if defective.		

FUEL INJECTION SYSTEM

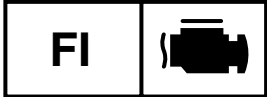



Fault code No.	33	Symptom	Malfunction detected in the primary lead of the ignition coil.	
Used diagnostic code No. 30 (ignition coil)				
Order	Item/components	Check or maintenance job	Restore method	
1	Coupler and connector connections Ignition coil primary connector (Orange) ECU coupler	Check the coupler and connector for any pins that may have pulled out. Check the connector and coupler are securely locked. If necessary, repair the coupler or securely connect it.	Reinstated by starting the engine and operating it at idle.	
2	Open or short circuit in the wire harness	Repair or replace if there is an open or short circuit between the wire harnesses. Orange - Orange		
3	Defective ignition coil	Execute the diagnostic mode. (Code No. 30) Test the primary and secondary coils for continuity. Replace the coil if it is defective. Refer to "IGNITION SYSTEM" in chapter 8. (Manual No.: 5VK1-AE1)		

Fault code No.	41	Symptom	Open or short circuit is detected in the lean angle cut-off switch.	
Used diagnostic code No. 08 (lean angle cut-off switch)				
Order	Item/components	Check or maintenance job	Restore method	
1	Coupler connections Lean angle cut-off switch coupler ECU coupler	Check the couplers for any pins that may have pulled out. Check that the couplers are securely locked. If necessary, repair the coupler or securely connect it.	Reinstated immediately when it becomes normal.	
2	Open or short circuit in the wire harness	Repair or replace if there is an open or short circuit between the wire harnesses. Black/Blue - Black/Blue Yellow/Green - Yellow/Green Blue - Blue		
3	Defective lean angle cut-off switch	Execute the diagnostic mode. (Code No. 08) Replace the switch if it is defective. Refer to "Fault code No. 30".		

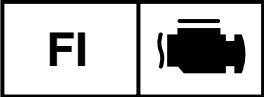
FUEL INJECTION SYSTEM

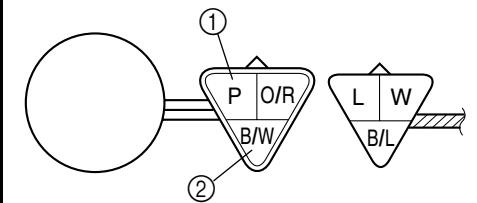

Fault code No.	42	Symptom	A. No normal signals are received from the speed sensor. B. Open or short circuit is detected in the neutral switch.
Used diagnostic code No. 07 (speed sensor) → A1 ~ A4 / No. 21 (neutral switch) → B1 ~ B4			
Order	Item/components	Check or maintenance job	Restore method
A-1	Coupler connections Speed sensor coupler ECU coupler	Check the couplers for any pins that may have pulled out. Check that the couplers are securely locked. If necessary, repair the coupler or securely connect it.	Reinstated by starting the engine, and inputting the vehicle speed signals by operating the motorcycle at 20 to 30 km/h (12.4 to 18.6 mi/h).
A-2	Open or short circuit in the wire harness	Repair or replace if there is an open or short circuit between the wire harnesses. Blue - Blue White - White Black/Blue - Black/Blue	
A-3	Gear for detecting vehicle speed has broken.	Replace the gear if it is defective. Refer to "TRANSMISSION" in chapter 5. (Manual No.: 5VK1-AE1)	
A-4	Defective speed sensor	Execute the diagnostic mode. (Code No. 07) Replace the sensor if it is defective. 1. Measure the speed sensor output voltage. 2. Connect the pocket tester (DC 20 V) to the speed sensor coupler as shown. <div style="border: 1px solid black; padding: 5px; margin: 5px 0;"> <p>Positive tester probe → pink ① Negative tester probe → black/white ②</p>  </div> 3. Set the main switch to "ON". 4. Elevate the rear wheel and slowly rotate it. 5. Measure the speed sensor output voltage. <div style="border: 1px solid black; padding: 5px; margin: 5px 0;">  <p>Speed sensor output voltage When sensor is on DC 4.8 V or more When sensor is off DC 0.6 V or less</p> </div> 6. Is the speed sensor OK?	

FUEL INJECTION SYSTEM

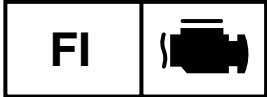

Fault code No.	42	Symptom	A. No normal signals are received from the speed sensor. B. Open or short circuit is detected in the neutral switch.
Used diagnostic code No. 07 (speed sensor) → A1 ~ A4 / No. 21 (neutral switch) → B1 ~ B4			
Order	Item/components	Check or maintenance job	Restore method
B-1	Coupler connections Neutral switch connector Wiring harness ECU coupler	Check the couplers for any pins that may have pulled out. Check that the couplers are securely locked. If necessary, repair the coupler or securely connect it.	Reinstated by starting the engine, and inputting the vehicle speed signals by operating the motorcycle at 20 to 30 km/h (12.4 to 18.6 mi/h).
B-2	Open or short circuit in the wire harness	Repair or replace if there is an open or short circuit between the wire harnesses. between neutral switch and relay unit Sky blue - Sky blue between relay unit and ECU Blue/Yellow - Blue/Black	
B-3	Faulty shift drum (neutral detection area)	Replace if defective. Refer to "TRANSMISSION" in chapter 5. (Manual No.: 5VK1-AE1)	
B-4	Defective neutral switch	Execute the diagnostic mode. (Code No. 21) Replace the switch if it is defective. Refer to "CHECKING THE SWITCHES" in chapter 8. (Manual No.: 5VK1-AE1)	

FUEL INJECTION SYSTEM

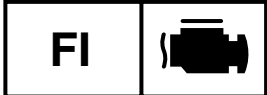

Fault code No.	43	Symptom	The ECU is unable to monitor the battery voltage.	
Used diagnostic code No. 09, 50 (fuel system voltage)				
Order	Item/components	Check or maintenance job	Restore method	
1	Coupler connections Fuel injection system relay coupler Wiring harness ECU coupler	Check the couplers for any pins that may have pulled out. Check that the couplers are securely locked. If necessary, repair the coupler or securely connect it.	Reinstated by starting the engine and operating it at idle.	
2	Defective main relay	Replace the relay if it is defective.		
3	Open or short circuit in the wire harness	Execute the diagnostic mode. (Code No. 09) Repair or replace if there is an open or short circuit: between battery and fuel injection system fuse Red - Red between fuel injection system fuse and fuel injection system relay Brown - Brown between fuel injection system relay and ECU Red/Blue - Red/Blue between battery and main switch Red - Red between main switch and ignition fuse Brown/Blue - Brown/Blue between ignition fuse and engine stop switch Red - Red between engine stop switch and fuel injection system relay Red/Black - Red/Black between fuel injection system relay and ECU Blue/Red - Blue/Red		
4	Malfunction or open circuit in the fuel injection system relay	Execute the diagnostic mode. (Code No. 50) Replace if defective. 1. Remove the relay unit. 2. Connect the pocket tester ($\Omega \times 1$) and battery (12 V) to the relay terminals as shown.	<div style="border: 1px solid black; padding: 5px; margin-bottom: 5px;"> Positive battery terminal → red/black ① Negative battery terminal → blue/red ② </div> <div style="border: 1px solid black; padding: 5px; margin-bottom: 5px;"> Positive tester probe → brown ③ Negative tester probe → red/blue ④ </div> <div style="border: 1px solid black; padding: 5px; text-align: center;"> </div>	
		3. Does the diode have continuity between brown and red/blue? If there is no malfunction with the fuel injection system relay, replace the ECU.		

FUEL INJECTION SYSTEM

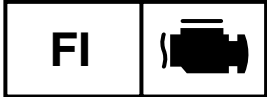

Fault code No.	44	Symptom	Error is detected while reading or writing on EEPROM (CO adjustment value).
-----------------------	----	----------------	---

Used diagnostic code No. 60 (EEPROM improper cylinder indication)

Order	Item/components	Check or maintenance job	Restore method
1	Malfunction in ECU	Execute the diagnostic mode. (Code No. 60) • Check the faulty cylinder. • Readjust the CO of the displayed cylinder. Refer to “ADJUSTING THE EXHAUST GAS VOLUME” in chapter 3. (Manual No.: 5VK1-AE1) Replace the ECU if it is defective.	Reinstated by setting the main switch to “ON”.

Fault code No.	46	Symptom	Power supply to the FI system relay is not normal.
-----------------------	----	----------------	--

Used diagnostic code No. 09

Order	Item/components	Check or maintenance job	Restore method
1	Faulty battery	Replace or change the battery. Refer to “CHECKING AND CHARGING THE BATTERY” in chapter 3. (Manual No.: 5VK1-AE1)	Reinstated by starting the engine and operating it at idle.
2	Open or short circuit in the wire harness.	Execute the diagnostic mode. (Code No. 09) Repair or replace if there is an open or short circuit: between battery and fuel injection system fuse Red - Red between the fuel injection system fuse and fuel injection system relay Brown - Brown between the fuel injection system relay and ECU Red/Blue - Red/Blue	
3	Coupler connections ECU coupler	Check the coupler for any pins that may have pulled out. Check that the coupler is securely locked. If necessary, repair the coupler or securely connect it.	

Fault code No.	50	Symptom	Faulty ECU memory. (When this malfunction is detected in the ECU, the fault code number might not appear on the meter.)
-----------------------	----	----------------	---

Used diagnostic code No. --

Order	Item/components	Check or maintenance job	Restore method
1	Malfunction in ECU	Replace the ECU.	Reinstated by setting the main switch to “ON”.

FUEL INJECTION SYSTEM

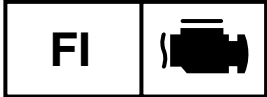

Fault code No. Er-1 Symptom No signals are received from the ECU.			
Used diagnostic code No. --			
Order	Item/components	Check or maintenance job	Restore method
1	Coupler connections ECU coupler Meter couplers	Check the couplers for any pins that may have pulled out. Check that the couplers are securely locked. If there is a malfunction, repair it and connect it securely.	Reinstated automatically when it receives a normal signal.
2	Malfunction in meter assembly	Replace the meter assembly.	
3	Malfunction in ECU	Replace the ECU.	

Fault code No. Er-2 Symptom No signals are received from the ECU within the specified duration.			
Used diagnostic code No. --			
Order	Item/components	Check or maintenance job	Restore method
1	Coupler connections ECU coupler Meter couplers	Check the couplers for any pins that may have pulled out. Check that the couplers are securely locked. If there is a malfunction, repair it and connect it securely.	Reinstated automatically when it receives a normal signal.
2	Malfunction in meter assembly	Replace the meter assembly.	
3	Malfunction in ECU	Replace the ECU.	

Fault code No. Er-3 Symptom Data from the ECU cannot be received correctly.			
Used diagnostic code No. --			
Order	Item/components	Check or maintenance job	Restore method
1	Coupler connections ECU coupler Meter couplers	Check the couplers for any pins that may have pulled out. Check that the couplers are securely locked. If there is a malfunction, repair it and connect it securely.	Reinstated automatically when it receives a normal signal.
2	Malfunction in meter assembly	Replace the meter assembly.	
3	Malfunction in ECU	Replace the ECU.	

Fault code No. Er-4 Symptom Non-registered data has been received from the meter.			
Used diagnostic code No. --			
Order	Item/components	Check or maintenance job	Restore method
1	Coupler connections ECU coupler Meter couplers	Check the couplers for any pins that may have pulled out. Check that the couplers are securely locked. If there is a malfunction, repair it and connect it securely.	Reinstated automatically when it receives a normal signal.
2	Malfunction in meter assembly	Replace the meter assembly.	
3	Malfunction in ECU	Replace the ECU.	

ELECTRICAL COMPONENTS

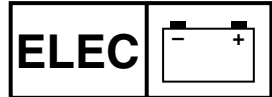

EAS00729

ELECTRICAL SYSTEM

ELECTRICAL COMPONENTS

- | | | |
|------------------------------|------------------------------|-----------------------------|
| ① Spark plug | ⑧ Main switch | ⑮ Lean angle cut-off switch |
| ② Spark plug cap | ⑨ Fuel pump | ⑯ Turn signal/hazard relay |
| ③ Ignition coil | ⑩ Clutch switch | ⑰ Headlight relay |
| ④ Intake air pressure sensor | ⑪ Left handlebar switch | ⑱ Radiator fan motor relay |
| ⑤ Front brake light switch | ⑫ Throttle position sensor | ⑲ Relay unit |
| ⑥ Right handlebar switch | ⑬ Coolant temperature sensor | ⑳ Battery |
| ⑦ Immobilizer unit | ⑭ Fuel injector | ㉑ Fuse box 1 |

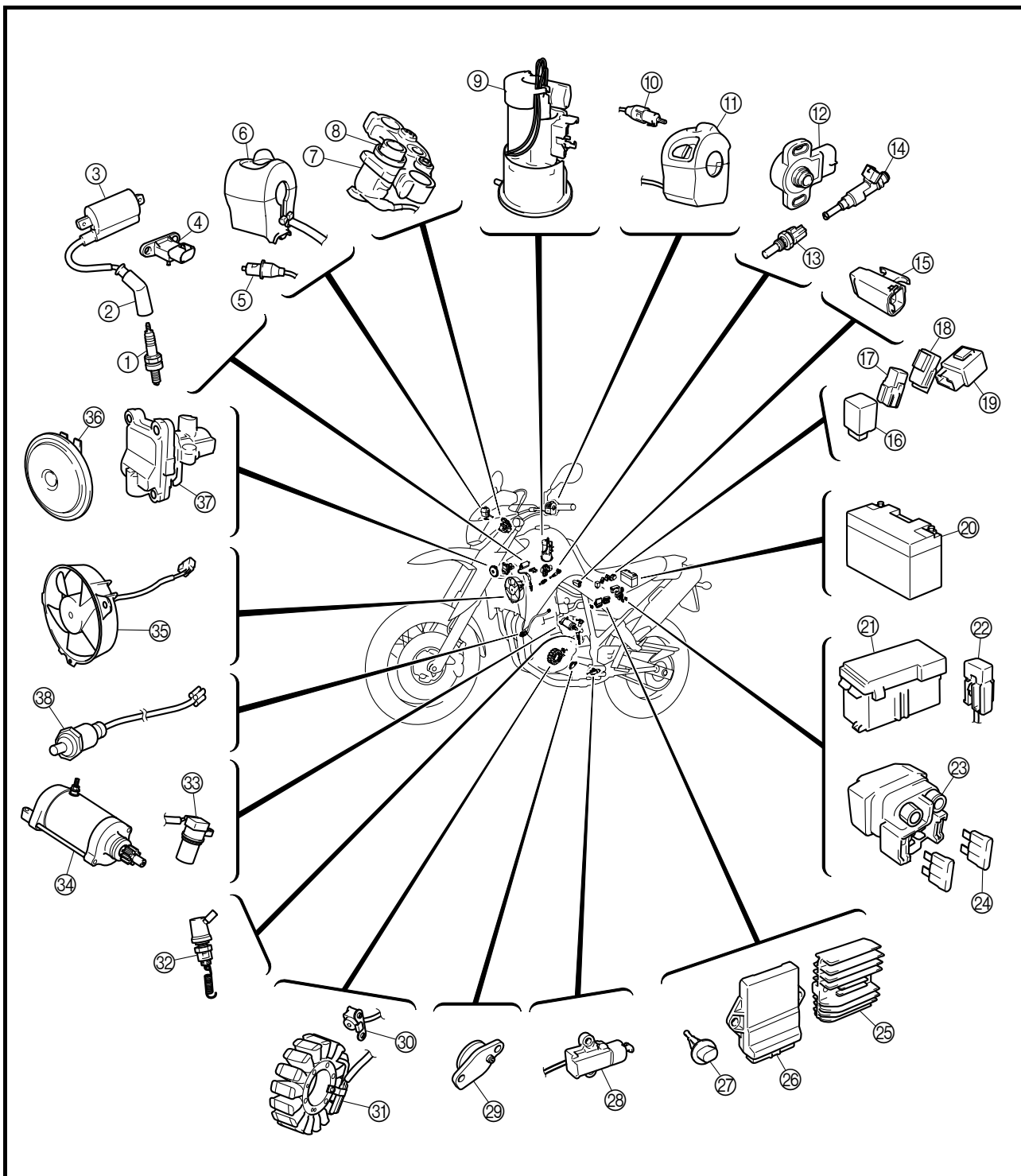

ELECTRICAL COMPONENTS

ELEC

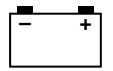

- 22 Fuse box 2
- 23 Starter relay
- 24 Main fuse
- 25 Rectifier/regulator
- 26 ECU
- 27 Intake air temperature sensor
- 28 Sidestand switch
- 29 Neutral switch
- 30 Crankshaft position sensor
- 31 Stator coil
- 32 Rear brake light switch
- 33 Speed sensor
- 34 Starter motor
- 35 Radiator fan motor
- 36 Horn
- 37 Air induction system solenoid
- 38 O₂ sensor

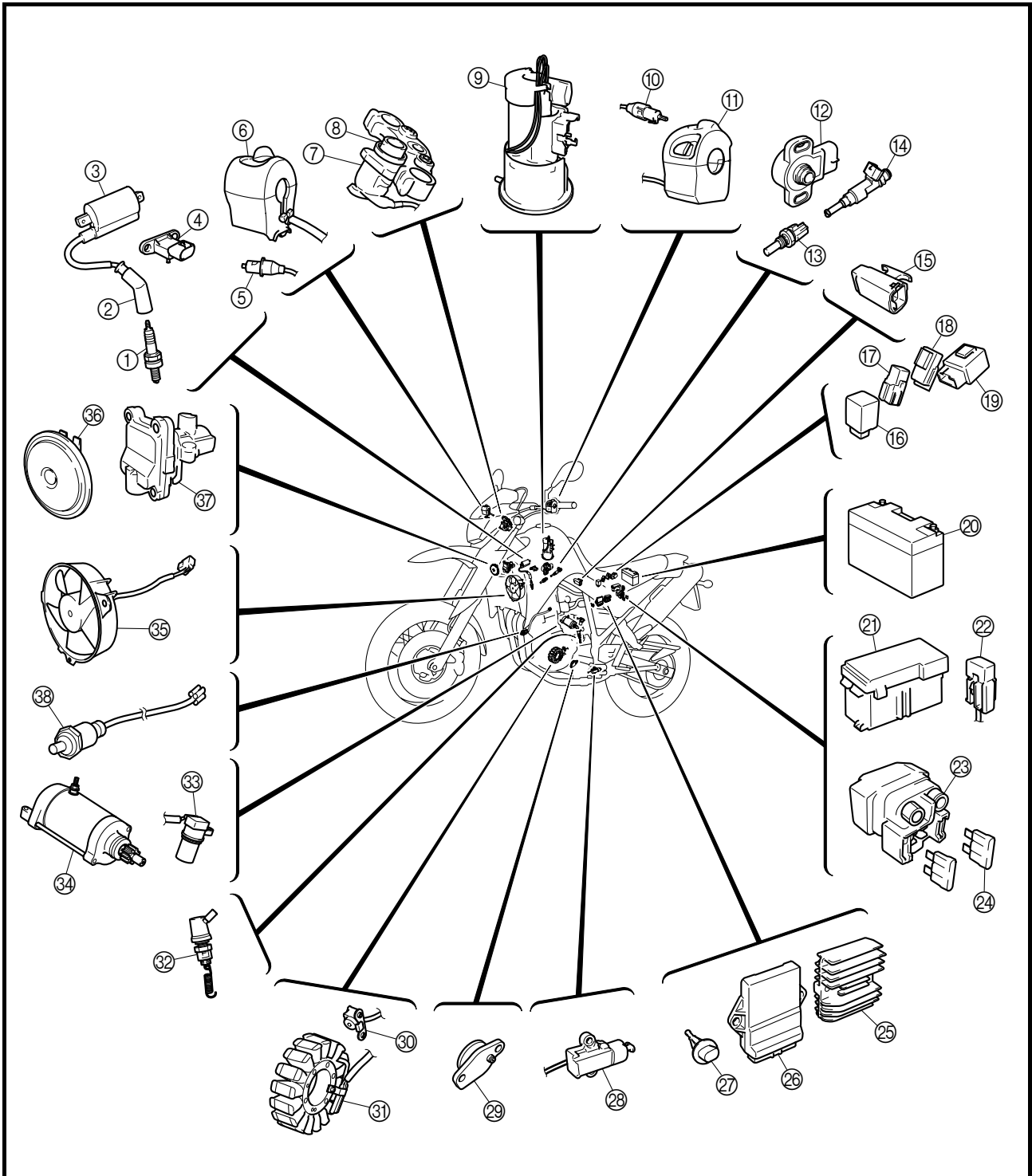

XT660R(W)/XT660X(W) 2007 WIRING DIAGRAM

- ① Crankshaft position sensor
- ② A.C. magneto
- ③ Neutral switch
- ④ Main switch
- ⑤ Rectifier/regulator
- ⑥ Battery
- ⑦ Main fuse
- ⑧ Starter relay
- ⑨ Starter motor
- ⑩ Fuel injection system fuse
- ⑪ Backup fuse (immobilizer unit, meter assembly)
- ⑫ Radiator fan motor fuse
- ⑬ Right handlebar switch
- ⑭ Engine stop switch
- ⑮ Start switch
- ⑯ Front brake light switch
- ⑰ Relay unit
- ⑱ Starting circuit cut-off relay
- ⑲ Fuel injection system relay
- ⑳ Sidestand switch
- ㉑ Fuel pump
- ㉒ ECU
- ㉓ Ignition coil
- ㉔ Spark plug
- ㉕ Fuel injector
- ㉖ Air induction system solenoid
- ㉗ Intake air temperature sensor
- ㉘ Coolant temperature sensor
- ㉙ Speed sensor
- ㉚ Throttle position sensor
- ㉛ Intake air pressure sensor
- ㉜ Lean angle cut-off switch
- ㉝ Meter assembly
- ㉞ Neutral indicator light
- ㉟ Multifunction meter
- ㊱ Coolant temperature warning light
- ㊲ Engine trouble warning light
- ㊳ Fuel level warning light
- ㊴ High beam indicator light
- ㊵ Turn signal indicator light
- ㊶ Immobilizer system indicator light
- ㊷ Headlight relay
- ㊸ Turn signal/hazard relay
- ㊹ Left handlebar switch
- ㊺ Horn switch
- ㊻ Pass switch
- ㊼ Dimmer switch
- ㊽ Turn signal switch
- ㊾ Hazard switch
- ㊿ Clutch switch
- ① Horn
- ② Headlight

- ③ Rear turn signal light (left)
- ④ Front turn signal light (left)
- ⑤ Front turn signal light (right)
- ⑥ Rear turn signal light (right)
- ⑦ Radiator fan motor relay
- ⑧ Radiator fan motor
- ⑨ Rear brake light switch
- ⑩ Auxiliary light
- ⑪ Tail/brake light
- ⑫ Ignition fuse
- ⑬ Signaling system fuse
- ⑭ Headlight fuse
- ⑮ Parking lighting fuse
- ⑯ Immobilizer unit
- ⑰ Anti-theft alarm (optional)
- ⑱ O₂ sensor

Ⓐ Optional

COLOR CODE

- BBlack
- BrBrown
- ChChocolate
- DgDark green
- GGreen
- GyGray
- LBlue
- LgLight green
- OOrange
- PPink
- RRed
- SbSky blue
- WWhite
- YYellow
- B/LBlack/Blue
- B/WBlack/White
- B/YBlack/Yellow
- Br/LBrown/Blue
- Br/RBrown/Red
- Br/WBrown/White
- G/LGreen/Blue
- G/RGreen/Red
- G/WGreen/White
- G/YGreen/Yellow
- Gy/GGray/Green
- L/BBlue/Black
- L/GBlue/Green
- L/RBlue/Red
- L/WBlue/White
- L/YBlue/Yellow
- O/ROrange/Red
- P/WPink/White
- R/BRed/Black
- R/GRed/Green
- R/LRed/Blue
- R/WRed/White
- R/YRed/Yellow
- Y/BYellow/Black
- Y/GYellow/Green
- Y/LYellow/Blue

MBK Industrie
Z.I de Rouvroy
02100 SAINT QUENTIN

Société Anonyme
au capital de 40 386 000 €
Téléphone : 33.(0)3.23.51.44.44
R.C St-Quentin B 329 035 422
Fax : 33.(0)3.23.51.45.02



MBK  **Industrie**

